

ORIENTATION
← FRONT

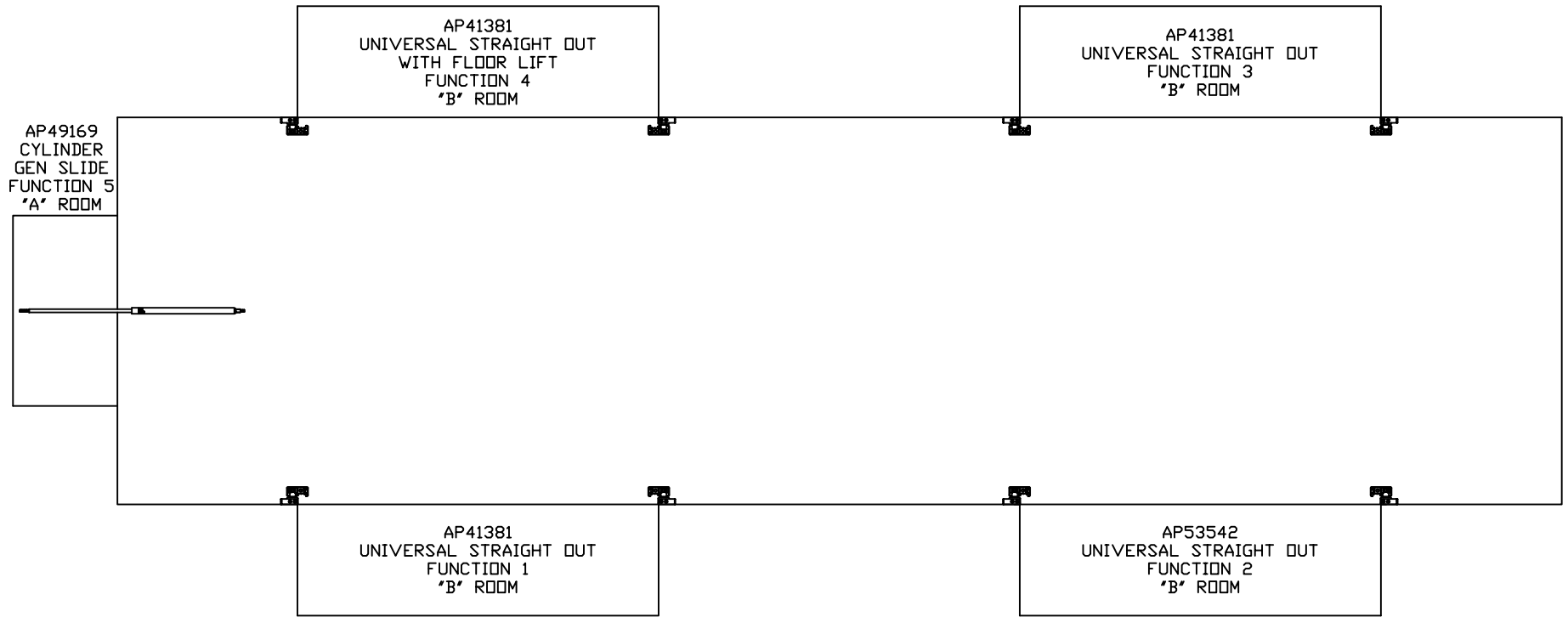

NOTE: INSTALLATION MUST CONFORM TO GOOD SHOP PRACTICES, SAE STANDARDS, RVIA STANDARDS, AND OTHER APPLICABLE STANDARDS.

LEVELING SYSTEM: AP57224

			HWH I-80 EXIT 267 SOUTH RT 1 MOSCOW, IDWA 52760		
SCALE 1:6		DATE 16NOV16	DRAWN BY .		
1	31MAR17	CORRECTED TYPO			
NO.	DATE	REVISION			
THE INFORMATION DISCLOSED ON THIS DRAWING IS CONFIDENTIAL AND MUST NOT BE DISCLOSED OR USED IN ANY MANNER WHICH WILL BE DETRIMENTAL TO THE HWH CORPORATION			HYD CONN DIAGRAM		
FORETRAVEL			DRAWING NUMBER MP71033 A/F		

NOTE: HOSES (E) AND (F) ARE INCLUDED WITH THE ROOM EXTENSION MECHANISM

(A) HOSE ASSY 04
PRESSURE

(B) .375" TUBING
RETURN

(C) HOSE ASSY 03
ROD END - ALWAYS PRESSURIZED - MUST MAINTAIN EQUAL LENGTH AND DIAMETER

(D) HOSE ASSY 03
CAP END - MUST MAINTAIN EQUAL LENGTH AND DIAMETER

(E) AP24632 HOSE ASSY 02 HP x 48'
ROD END - ALWAYS PRESSURIZED - MUST MAINTAIN EQUAL LENGTH AND DIAMETER

(F) AP24818 HOSE ASSY 02 HP x 86'
CAP END - MUST MAINTAIN EQUAL LENGTH AND DIAMETER

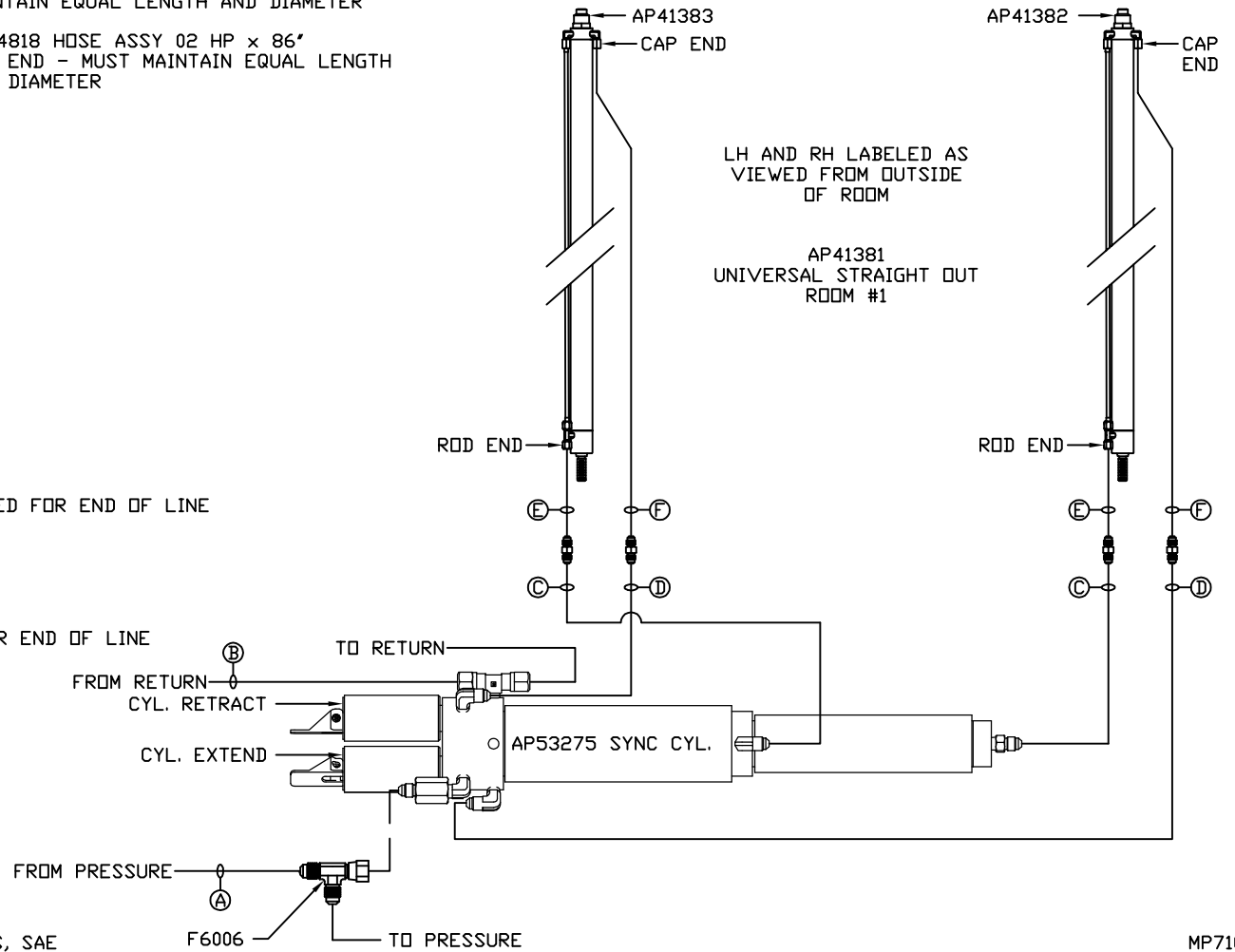
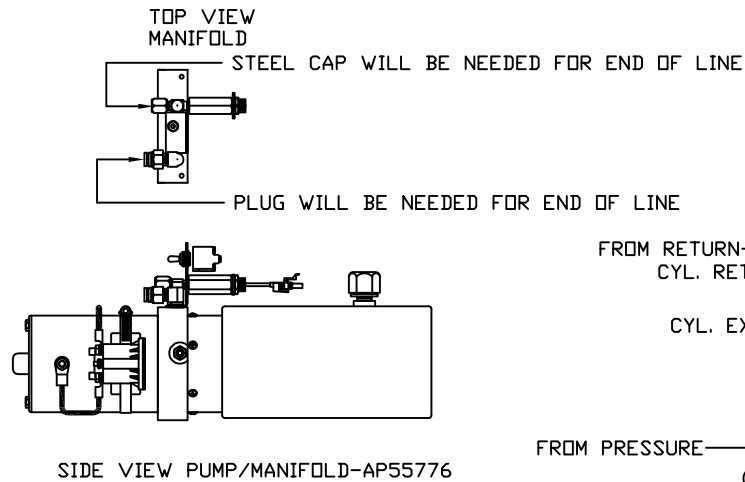

NOTE: INSTALLATION MUST CONFORM TO GOOD SHOP PRACTICES, SAE STANDARDS, RVIA STANDARDS, AND OTHER APPLICABLE STANDARDS.

MP71033 B/F
16NOV16

NOTE: HOSES (E) AND (F) ARE INCLUDED WITH THE ROOM EXTENSION MECHANISM

(A) HOSE ASSY 04
PRESSURE

(B) .375" TUBING
RETURN

(C) HOSE ASSY 03
ROD END - ALWAYS PRESSURIZED - MUST
MAINTAIN EQUAL LENGTH AND DIAMETER

(D) HOSE ASSY 03
CAP END - MUST MAINTAIN EQUAL LENGTH
AND DIAMETER

(E) AP24631 HOSE ASSY 02 HP x 42"
ROD END - ALWAYS PRESSURIZED - MUST
MAINTAIN EQUAL LENGTH AND DIAMETER

(F) AP24637 HOSE ASSY 02 HP x 66"
CAP END - MUST MAINTAIN EQUAL LENGTH
AND DIAMETER

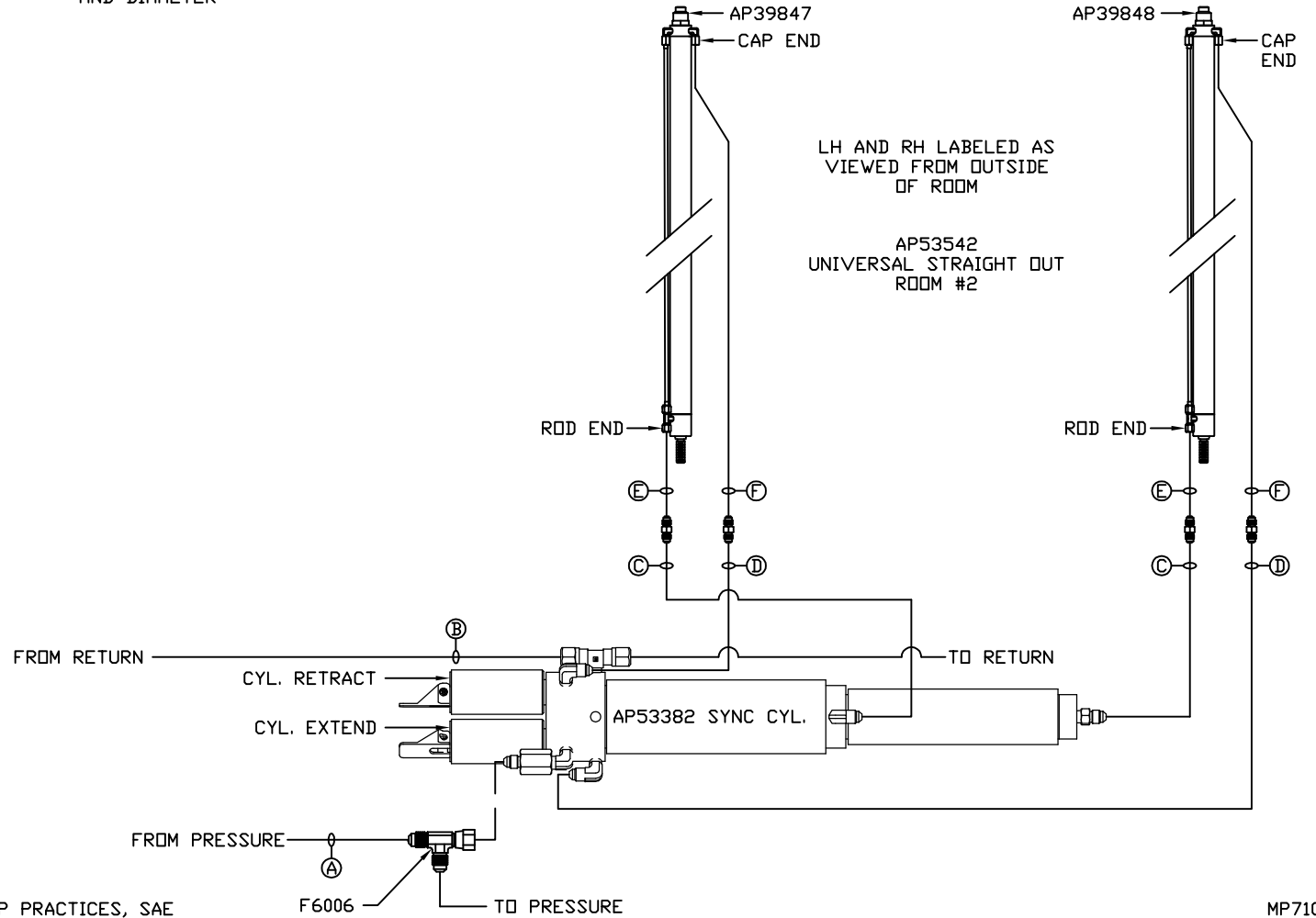

NOTE: INSTALLATION MUST CONFORM TO GOOD SHOP PRACTICES, SAE STANDARDS, RVIA STANDARDS, AND OTHER APPLICABLE STANDARDS.

MP71033 C/F
16NOV16

NOTE: HOSES (E) AND (F) ARE INCLUDED WITH THE ROOM EXTENSION MECHANISM

(A) HOSE ASSY 04
PRESSURE

(B) .375" TUBING
RETURN

(C) HOSE ASSY 03
ROD END - ALWAYS PRESSURIZED - MUST
MAINTAIN EQUAL LENGTH AND DIAMETER

(D) HOSE ASSY 03
CAP END - MUST MAINTAIN EQUAL LENGTH
AND DIAMETER

(E) AP24632 HOSE ASSY 02 HP x 48"
ROD END - ALWAYS PRESSURIZED - MUST
MAINTAIN EQUAL LENGTH AND DIAMETER

(F) AP24818 HOSE ASSY 02 HP x 86"
CAP END - MUST MAINTAIN EQUAL LENGTH
AND DIAMETER

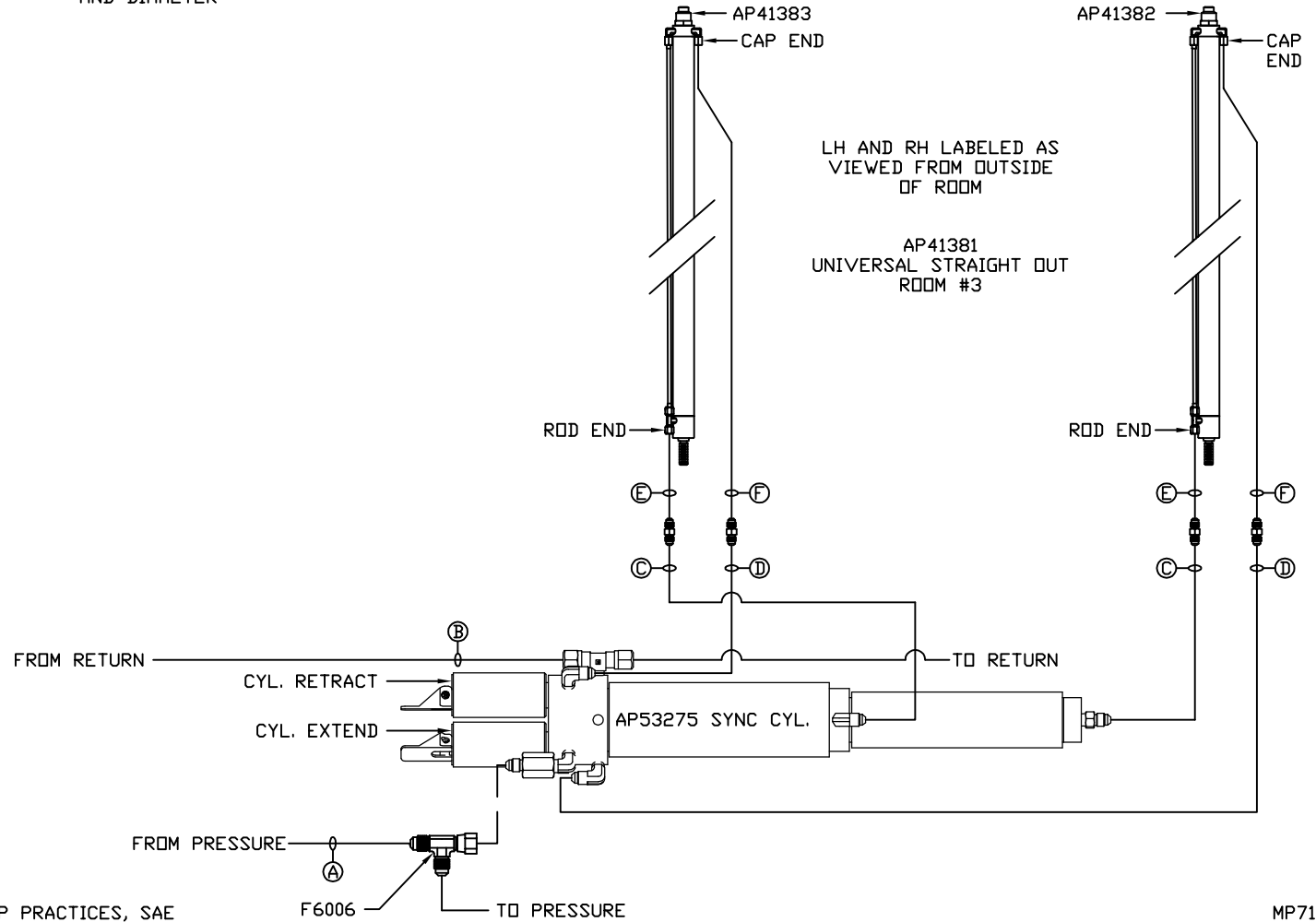

NOTE: INSTALLATION MUST CONFORM TO GOOD SHOP PRACTICES, SAE STANDARDS, RVIA STANDARDS, AND OTHER APPLICABLE STANDARDS.

MP71033 D/F
16NOV16

- Ⓐ HOSE ASSY 04
PRESSURE
- Ⓑ .375" OD NYLON TUBING
RETURN
- Ⓒ HOSE ASSY 03
ROD END - ALWAYS PRESSURIZED - MUST
MAINTAIN EQUAL LENGTH AND DIAMETER
- Ⓓ HOSE ASSY 03
CAP END - MUST MAINTAIN EQUAL LENGTH
AND DIAMETER
- Ⓔ AP24632 HOSE ASSY 02 HP x 48"
ROD END - ALWAYS PRESSURIZED - MUST
MAINTAIN EQUAL LENGTH AND DIAMETER
- Ⓕ AP24818 HOSE ASSY 02 HP x 86"
CAP END - MUST MAINTAIN EQUAL LENGTH
AND DIAMETER
- Ⓖ AP4218 HOSE ASSY 04 x 40"
CAP END (LIFT)
- Ⓙ AP4062 HOSE ASSY 04 x 132"
CAP END (LIFT)
- Ⓚ AP5350 HOSE ASSY 04 x 57"
CAP END (ROOM)
- Ⓛ AP4073 HOSE ASSY 04 x 60"
ROD END (LIFT) - ALWAYS
PRESSURIZED
- Ⓜ AP7177 HOSE ASSY 04 x 70"
CAP END (LIFT)
- Ⓝ AP4075 HOSE ASSY 04 x 42"
ROD END - ALWAYS PRESSURIZED (LIFT)

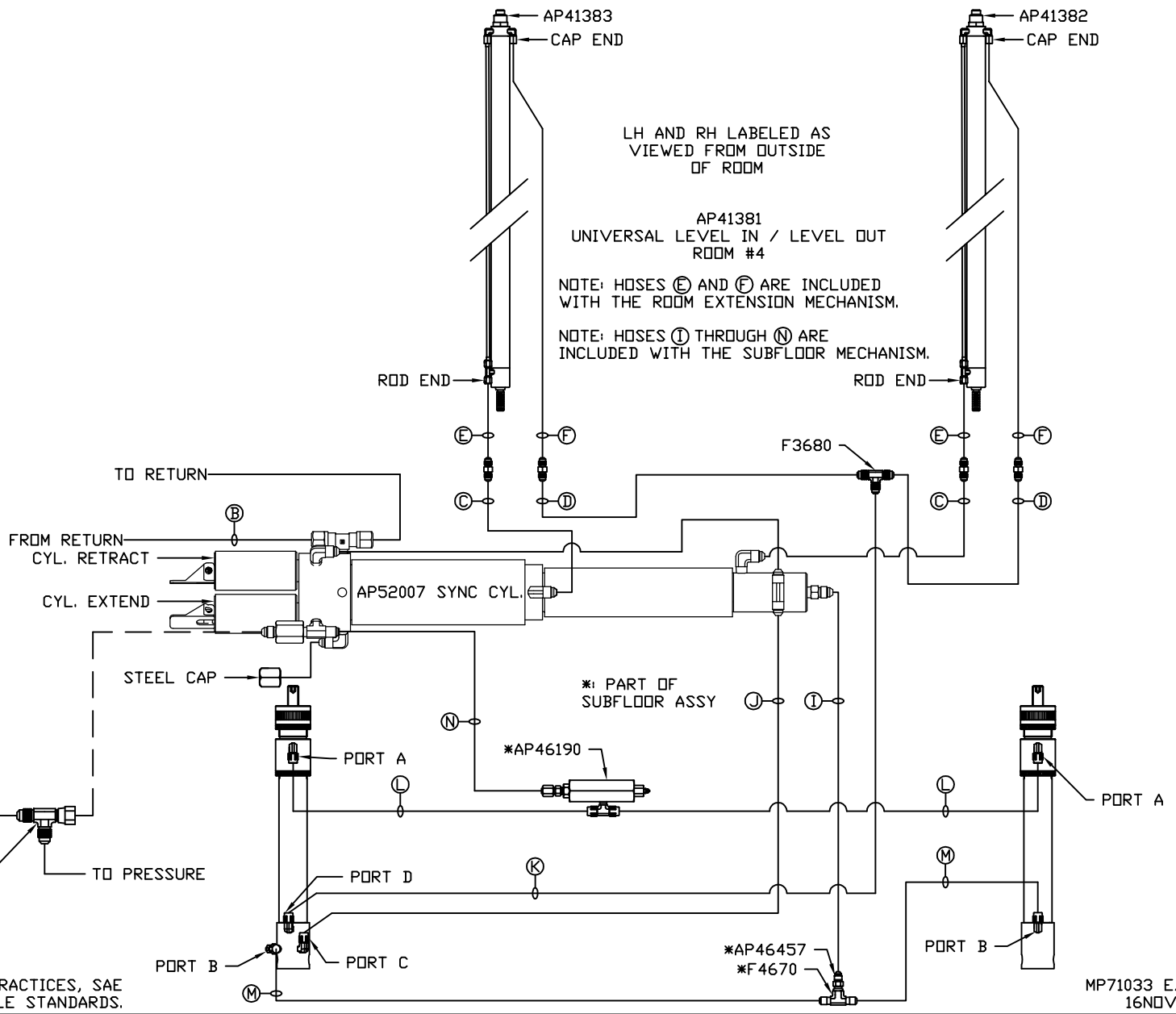

NOTE: INSTALLATION MUST CONFORM TO GOOD SHOP PRACTICES, SAE STANDARDS, RVIA STANDARDS, AND OTHER APPLICABLE STANDARDS.

- Ⓐ HOSE ASSY 03
CAP END
- Ⓑ HOSE ASSY 03
ROD END - ALWAYS PRESSURIZED
- Ⓒ HOSE ASSY 04
PRESSURE
- Ⓓ .375" TUBING
RETURN

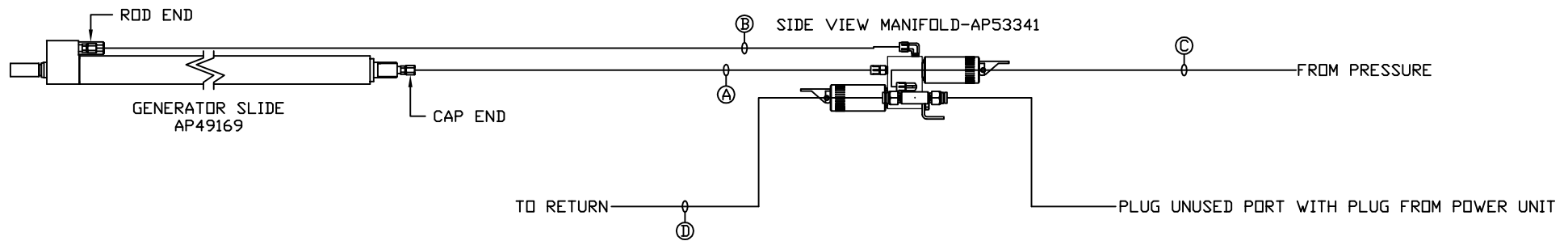

NOTE: INSTALLATION MUST CONFORM TO GOOD SHOP PRACTICES, SAE STANDARDS, RVIA STANDARDS, AND OTHER APPLICABLE STANDARDS.

MP71033 F/F
16NOV16