

ORIENTATION  
FRONT

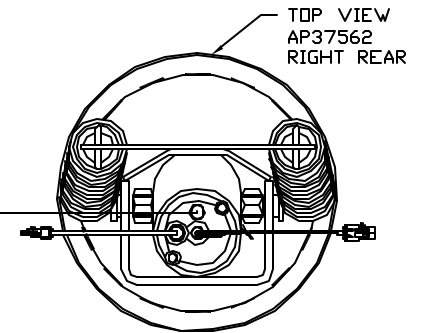

- Ⓐ AP4827 HOSE ASSY .25' X 144'
- Ⓑ AP5965 HOSE ASSY .25' X 180'
- Ⓒ AP22313 HOSE ASSY .313' X 192'
- Ⓓ AP31034 HOSE ASSY .313' X 288'
- Ⓔ \*AP4060 HOSE ASSY .25 X 24"
- Ⓕ \*RETURN LINE .5" OD TUBING

NOTE: CROSS TIES REQUIRED FOR REAR JACKS

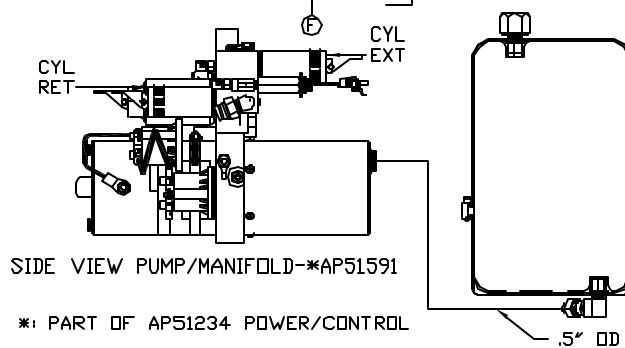
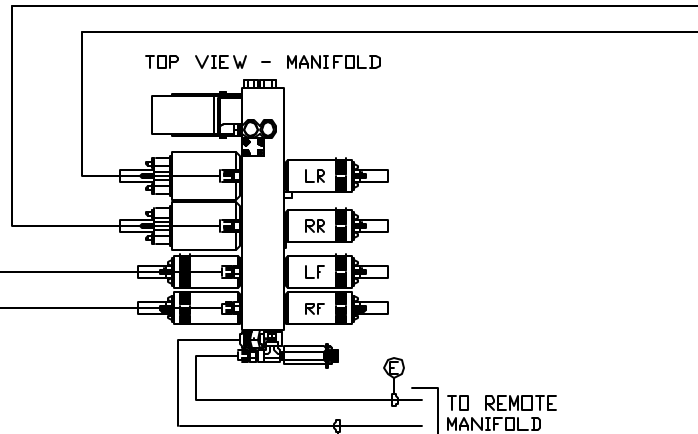
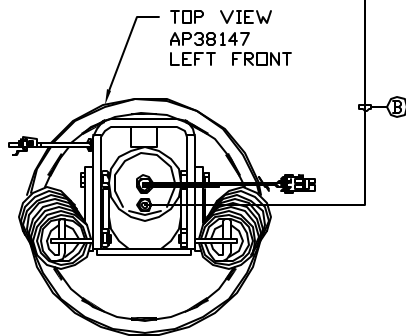
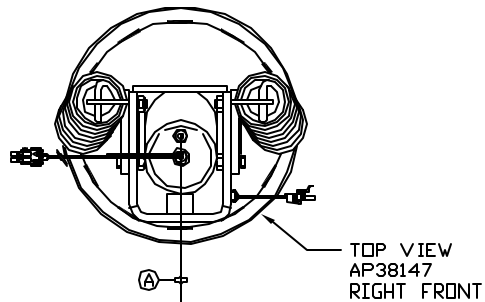
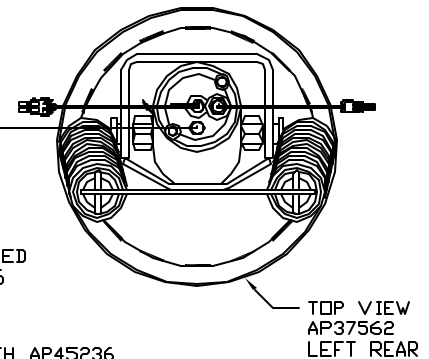

NOTE: INSTALLATION MUST CONFORM TO GOOD SHOP PRACTICES, SAE STANDARDS, RVIA STANDARDS, AND OTHER APPLICABLE STANDARDS.

LEVELING SYSTEM AP51230

		HWH		I-80 EXIT 267 SOUTH RT 1 MOSCOW, IDWA 52760	
		SCALE 1:6	DATE 21AUG13	DRAWN BY .	
		HYD CONN DIAGRAM			
NO.	DATE	REVISION			
		SVI TRUCKS		DRAWING NUMBER MP70657 A/B	

THE INFORMATION DISCLOSED ON THIS DRAWING IS CONFIDENTIAL AND MUST NOT BE DISCLOSED OR USED IN ANY MANNER WHICH WILL BE DETRIMENTAL TO THE HWH CORPORATION

NOTE: HOSES (E) AND (F) ARE INCLUDED WITH THE ROOM EXTENSION MECHANISM

(A) .25" ID HOSE ASSY  
ROD END - ALWAYS PRESSURIZED

(B) .25" ID HOSE ASSY  
CAP END (ROOM)

(C) .03 HOSE ASSY  
ROD END - ALWAYS PRESSURIZED  
HOSES MUST MAINTAIN EQUAL LENGTH AND DIAMETER

(D) .25" ID HOSE ASSY  
CAP END - HOSES MUST MAINTAIN EQUAL LENGTH AND DIAMETER

(E) AP24632 HOSE ASSY HWH02HP x 48'  
ROD END - ALWAYS PRESSURIZED - HOSES MUST MAINTAIN EQUAL LENGTH AND DIAMETER

(F) AP24818 HOSE ASSY HWH02HP x 86'  
CAP END - MUST MAINTAIN EQUAL LENGTH AND DIAMETER

(I) .25" ID HOSE ASSY  
CAP END (LIFT)

(J) .25" ID HOSE ASSY  
CAP END (ROOM)

(K) .25" ID HOSE ASSY  
CAP END (ROOM)

(L) .25" ID HOSE ASSY ROD END (LIFT)  
ALWAYS PRESSURIZED

(M) .25" ID HOSE ASSY  
CAP END (LIFT)

(N) .25" ID HOSE ASSY  
ROD END - ALWAYS PRESSURIZED (LIFT)

(O) .25" ID HOSE ASSY ROD END (LIFT)  
ALWAYS PRESSURIZED

(P) .25" ID HOSE ASSY  
CAP END LIFT

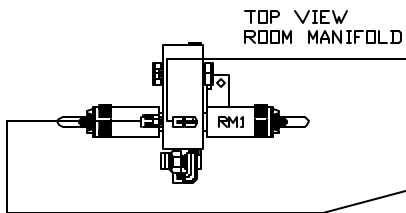

(NOTE: GENERIC VIEWS FOR CLARITY. CYLINDERS MAY BE REVERSED)

NOTE: INSTALLATION MUST CONFORM TO GOOD SHOP PRACTICES, SAE STANDARDS, RVIA STANDARDS, AND OTHER APPLICABLE STANDARDS.

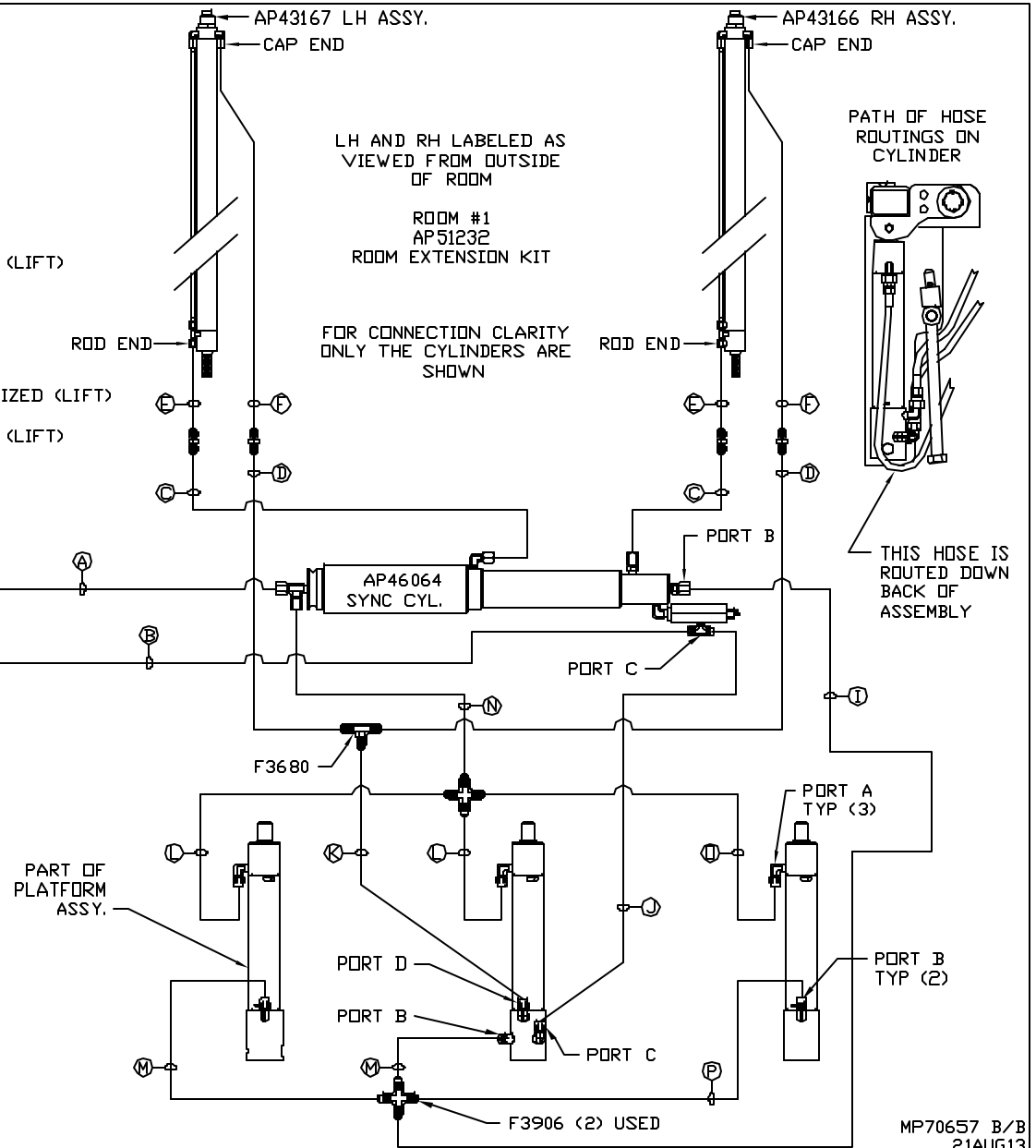

MP70657 B/B  
21AUG13