



OPERATOR'S MANUAL

HWH® 725 Series, Computer-Controlled Hydraulic Leveling System

FEATURING:

BI-AXIS® Touch Panel Control

Straight-Acting/Pivoting (Power-Extend/Spring-Retract) Jacks

Pilot Air Dump

Two HWH® SpaceMaker® Slide-Out Systems

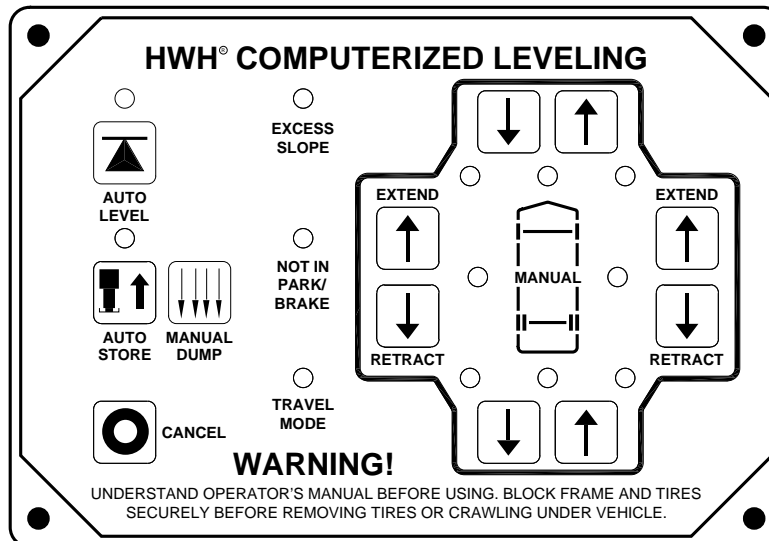

HWH CORPORATION

(On I-80, Exit 267 South)

2096 Moscow Road | Moscow, Iowa 52760

Ph: 800/321-3494 (or) 563/724-3396 | Fax: 563/724-3408

www.hwh.com

OPERATOR'S MANUAL

WARNING !

READ THE ENTIRE OPERATOR MANUAL BEFORE OPERATING.

BLOCK FRAME AND TIRES SECURELY BEFORE CRAWLING UNDER VEHICLE. DO NOT USE LEVELING JACKS OR AIR SUSPENSION TO SUPPORT VEHICLE WHILE UNDER VEHICLE OR CHANGING TIRES. VEHICLE MAY DROP AND/OR MOVE FORWARD OR BACKWARD WITHOUT WARNING CAUSING INJURY OR DEATH.

KEEP ALL PEOPLE CLEAR OF VEHICLE WHILE OPERATING LEVELING SYSTEM OR ROOM EXTENSIONS.

KEEP ALL PEOPLE CLEAR OF VEHICLE WHILE DUMPING AIR FROM THE VEHICLE'S SUSPENSION.

DO NOT MOVE THE VEHICLE IF THE VEHICLE IS NOT AT THE PROPER RIDE HEIGHT. CONTACT MANUFACTURER TECHNICAL SERVICE FOR MOVING THE VEHICLE WHEN NOT AT THE PROPER RIDE HEIGHT.

WEAR SAFETY GLASSES WHEN INSPECTING OR SERVICING THE SYSTEM TO PROTECT EYES FROM DIRT, METAL CHIPS, OIL LEAKS, ETC. FOLLOW ALL OTHER APPLICABLE SHOP SAFETY PRACTICES.

IMPORTANT: IF COACH IS EQUIPPED WITH A ROOM EXTENSION, READ ROOM EXTENSION SECTION BEFORE OPERATING LEVELING SYSTEM.

HWH maintains technical and information services at 800-321-3494 or 563-724-3396. Assistance is available Monday thru Friday from 8:00A.M until 5:00P.M. C.S.T.

Technical and information service is also available on-line at www.hwh.com.

CONTROL IDENTIFICATION

725 SERIES LEVELING SYSTEM

COMPUTER-CONTROL

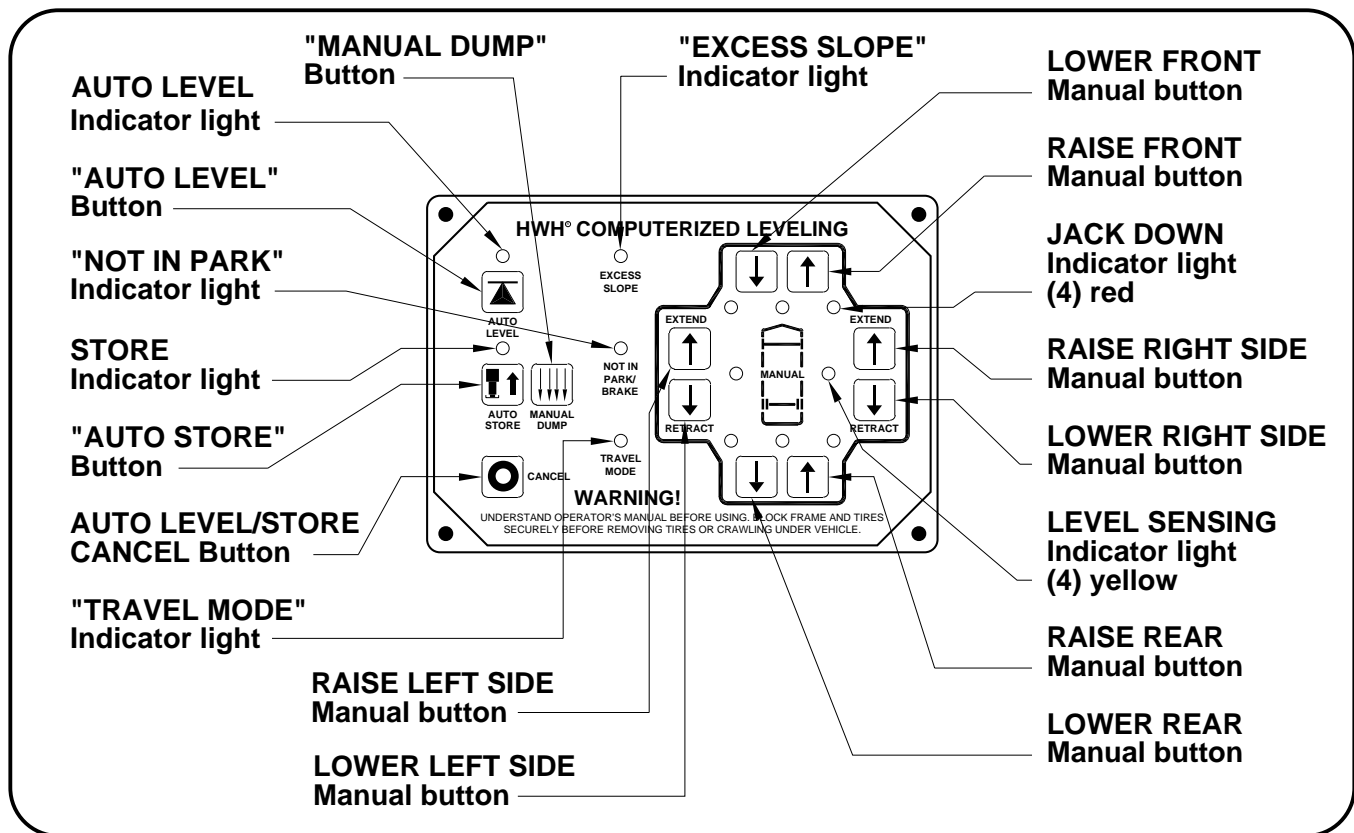

CONTROL FUNCTIONS

CONTROL BUTTONS

"CANCEL" BUTTON: Push this button to stop any leveling system operation.

"AUTO LEVEL" BUTTON: Push this button any time to start the automatic leveling function.

"AUTO STORE" BUTTON: Push this button to retract all four jacks at the same time.

"MANUAL DUMP" BUTTON: This is a manual button for dumping air from the vehicle suspension.

EXTEND BUTTONS (UP ARROWS): These buttons will extend their respective jack pairs to lift the vehicle.

RETRACT BUTTONS (DOWN ARROWS): These buttons will retract their respective jack pairs to lower the vehicle.

INDICATOR LIGHTS

AUTO LEVEL INDICATOR LIGHT: This light will flash during the automatic leveling function.

STORE INDICATOR LIGHT: This light will flash during the automatic store function.

"EXCESS SLOPE" LIGHT: This indicator will light when the leveling system cannot level the vehicle.

INDICATOR LIGHTS (CONTINUED)

LEVELING LIGHTS: The four yellow indicating lights are level sensing indicators. When a yellow light is on, it indicates that its side, end, or corner of the vehicle is low. No more than two lights should be on at the same time. When all four yellow LEVEL lights are out, the vehicle is level.

WARNING LIGHTS: The four red lights surrounding the yellow level indicators are jacks down WARNING lights. They are functional only when the ignition is in the "ON" or "ACC" position, the system is on, and the jacks are extended approximately 1 inch.

"NOT IN PARK/BRAKE" LIGHT: This indicator will light when the hand/auto brake is not set and the "AUTO LEVEL" button is being pushed.

"TRAVEL MODE" LIGHT: This indicator light will be on when the ignition is on, when the jacks are retracted and there are no red WARNING lights on.

MASTER "JACKS DOWN" WARNING LIGHT: This is a light mounted in the dash separate from the touch panel. It will be on when any one or more jacks are extended and the ignition is "ON".

BUZZER: This is a jacks down warning. It will sound if the master "JACKS DOWN" warning light is on.

MP24.3151
17FEB21

CONTROL IDENTIFICATION

PUMP RUN TIME

PUMP RUN TIME

Pump motors used with HWH leveling systems and room extension systems come in 3 different diameters; 3", 3.7" and 4.5". Contact the vehicle manufacturer or HWH for help with identifying the motor size. **It is important that any time the pump runs for more than three minutes with a 3" motor; or six minutes with a 3.7" or 4.5" motor that the motor is allowed to cool for thirty minutes before continuing. Continuous operation of the pump motor without allowing the motor to cool can damage the motor.** For cold weather information see "COLD WEATHER OPERATIONS" below.

The HWH systems with a computer processor monitor the pump run time and will turn the pump off if the run time exceeds a specified time. This time can vary with different systems. Due to available electronics or system design, the pump run time programs will also vary. Leveling systems and room extensions that are not controlled by a system processor have no pump run time protection. **DO NOT run the pump more than three or six minutes without allowing the pump motor to cool for thirty minutes.**

SYSTEM VARIATIONS FOR PUMP RUN TIME

Some systems with rooms run the rooms separate from the system processor. These systems do not monitor pump run time when operating the rooms. **DO NOT run the pump more than three or six minutes without allowing the pump motor to cool for thirty minutes.**

Some systems can be turned back on immediately after the processor turns the pump off. **DO NOT turn the system back on or run the pump without allowing the pump motor to cool for thirty minutes.**

When operating some leveling systems manually or operating the room extensions, the pump will turn off and back on while pushing the control button when the pump run time has been exceeded. **DO NOT continue without allowing the pump motor to cool for thirty minutes.**

With some systems, when the processor has turned the pump off because the run time has been exceeded, power to the HWH system must be turned off and back on before the system will operate. With motorized vehicles, turn the ignition off and back on. With non-motorized vehicles, turn the master power switch for the HWH system off and back on. **DO NOT continue without allowing the pump motor to cool for thirty minutes.**

Some HWH systems are equipped with a lighted reset switch. If the processor turns the pump off because the run time has been exceeded, the light in the reset switch will turn on. The system will not operate until the reset switch is pushed.

DO NOT continue without allowing the pump motor to cool for thirty minutes.

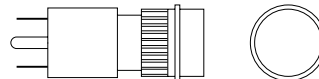

LIGHTED RESET SWITCH

No matter what HWH system is on the vehicle, the pump should not be ran for more than three minutes (3" motors) or six minutes (3.7" or 4.5" motors) without allowing the pump motor to cool for thirty minutes. Continuous operation of the pump motor without allowing the motor to cool can damage the pump motor.

Contact HWH corporation to get specific information about the system in this vehicle.

COLD WEATHER OPERATIONS

HWH leveling and room extension systems are designed to function in cold weather down to 0 degrees Fahrenheit. Below freezing (32 degrees Fahrenheit) the jacks or rooms will operate slower than usual.

For operation in temperatures dropping below -20 degrees Fahrenheit, it is necessary that the system is equipped with oil designed for extreme cold weather application such as a synthetic oil. (Contact HWH for recommendations.)

DO NOT run the pump motor continuously. It is important that any time the pump runs for more than three minutes with a 3" motor; or six minutes with a 3.7" or 4.5" motor that the motor is allowed to cool for thirty minutes before continuing. Continuous operation of the pump motor without allowing the motor to cool can damage the motor. Continuous operation of the pump with slow moving jacks or rooms in cold weather, without allowing the pump motor to cool will cause the pump motor to burn up and damage the pump assembly.

OPERATING PROCEDURES

GENERAL INSTRUCTIONS

Maintain adequate clearance in all directions for vehicle, room extensions, awnings, doors, steps, etc. Vehicle may move in any direction due to jacks extending or retracting, settling of the jacks or the vehicle, equipment malfunction, etc..

If parking on soft ground or asphalt paving, a wood block or pad should be placed under each jack.

Press the "CANCEL" button or turn the ignition switch "OFF" at any time to stop the operation of the system.

Any time a hydraulic leveling process is interrupted, it is recommended to retract the jacks according to the JACK RETRACTION Section and then restart the leveling process.

If the hand / auto brake is not set when the "AUTO LEVEL" button is pressed, the "NOT IN PARK/BRAKE" light will come on. When the "AUTO LEVEL" button is released the "NOT IN PARK/BRAKE" light will go out. The Automatic Leveling function will not start.

WARNING: DO NOT MOVE THE VEHICLE IF ONE OR MORE JACKS ARE EXTENDED TO THE GROUND.

PREPARATION FOR TRAVEL

IMPORTANT: Before traveling, the red jack warning lights must be off the "TRAVEL MODE" light must be on and the vehicle should be at the proper height for travel. If lights are not correct for travel, retract jack as described in the JACK RETRACTION Section.

If the jacks are retracted but a red "WARNING" light is lit the system needs to be serviced.

Any room extension or generator slide should be fully retracted before traveling.

WARNING: DO NOT MOVE THE VEHICLE WHILE THE LEVELING JACKS ARE STILL IN CONTACT WITH THE GROUND OR IN THE EXTEND POSITION. THIS VEHICLE IS EQUIPPED WITH STRAIGHT-ACTING JACKS. MOVING THE VEHICLE WITH THE LEVELING JACKS EXTENDED CAN CAUSE SEVERE DAMAGE TO THE JACKS AND OR THE VEHICLE AND CREATE A DRIVING

HAZARD. DO NOT RELY SOLELY UPON WARNING LIGHTS. IT IS THE OPERATOR'S RESPONSIBILITY TO CHECK THAT ALL JACKS ARE FULLY RETRACTED INTO THE STORE/TRAVEL POSITION AND THE VEHICLE IS AT THE PROPER RIDE HEIGHT FOR TRAVELING. CONTACT MANUFACTURER TECHNICAL SERVICE BEFORE MOVING A VEHICLE THAT IS NOT AT PROPER TRAVEL HEIGHT.

If the jacks cannot be retracted according to the JACK RETRACTION Section, retract the jacks according to the MANUAL JACK RETRACTION Section. The system should then be checked.

NOTE: If the vehicle is parked or stored with the jacks extended for an extended period of time and the jacks fail to retract completely, extend the jacks back down to the ground then retract the jacks again.

OPERATING PROCEDURES

725 SERIES LEVELING SYSTEM

AUTOMATIC HYDRAULIC LEVELING (HWH TOUCH PANEL CONTROLS)

1. Place transmission in the recommended position for parking the vehicle and set parking brake. Turn the coach engine off. Turn the ignition to the "ACCESSORY" position.

NOTE: One or two yellow level indicator lights on the leveling system touch panel can be on anytime the vehicle ignition is in the ON or ACC. position and the park brake is set.

2. At this time, the operator may want to check the jacks and place a pad under each jack if the ground will not support the vehicle.

WARNING: PRIOR TO PUSHING THE "AUTO LEVEL" BUTTON THE OPERATOR MUST BE SURE THAT ALL PERSONS AND OBJECTS ARE CLEAR OF THE VEHICLE. AIR WILL BE EXHAUSTED FROM THE VEHICLE SUSPENSION AND THE VEHICLE WILL LOWER IMMEDIATELY AFTER THE "AUTO LEVEL" BUTTON IS PUSHED.

3. Press the "AUTO LEVEL" button one time. The AUTO LEVEL light will start to flash. The system will begin to dump air from the vehicle suspension. After approximately 25 seconds, the leveling process will begin.

IMPORTANT: During the Automatic Leveling procedures, pushing the "AUTO LEVEL", "AUTO STORE" or the "CANCEL" button on the HWH touch panel will stop the automatic leveling function.

When a jack extends approximately 1 inch, it's individual red warning light on the touch panel will come on. The touch panel "TRAVEL MODE" light will go out. If the ignition is in the ON position, the warning buzzer will sound.

AUTO LEVEL SEQUENCE: During the automatic leveling sequence, after the system has extended the appropriate jacks to level the vehicle and has turned the yellow level indicator lights off, the system will then stabilize the vehicle.

STABILIZE SEQUENCE: The stabilize sequence is part of the Auto Level sequence. Each jack has a pressure switch. The switch will turn on when the jack extends to the ground and lifts the vehicle slightly. Jacks that have lifted the vehicle for leveling should have pressure switches that are on.

The stabilize procedure is a specific sequence where the computer checks the jack pressure switches. If the switch is on, the jack is already stabilizing the vehicle. If the switch is not on, the computer turns the pump and valve on for that jack until the pressure switch turns on.

The sequence starts with the right rear jack. If the pressure switch is not on, the system will extend the jack as necessary. If the switch is on (or when it comes on) the system will check the left rear jack pressure switch, extending the jack if necessary. If the left rear switch is on (or when it comes on), the system will recheck the right rear (extending if necessary) then recheck the left rear (extending if necessary). After checking and rechecking both rear jacks, the system then checks the front jacks. The system checks both front jacks at the same time. If either pressure switch is not on, the system will turn the pump on and open the valves for both front jacks. When both front pressure switches are on, the system turns the pump and front valves off.

The slight lift experienced during the stabilizing procedure normally is not sufficient to cause a level issue for the motor home. However, a feature of the single step leveling system is the manual leveling buttons will function anytime the ignition is in the ON or ACC. position and the park brake is set. If desired, the operator can use the UP ARROWS (extend jacks) that correspond to any lit yellow level indicator light to "bump" the vehicle up slightly to turn that yellow indicator light off.

EXCESS SLOPE SITUATION: In the event the jacks are unable to level the coach, the "EXCESS SLOPE" light will come on. Excess slope is when one or two jacks extend fully without turning the yellow level light out. The system will not stabilize the vehicle if the "EXCESS SLOPE" light comes on. One or more jacks may not be extended. The system will shut off, leaving the "EXCESS SLOPE" light on. The "EXCESS SLOPE" light will remain on for two minutes if the ignition is in the "ON" or "ACC" position.

Retract the jacks and move the vehicle to a more level position or level the vehicle as close as possible according to the MANUAL HYDRAULIC OPERATION section. The "AUTO STORE" button will function if the "EXCESS SLOPE" light is on. The manual UP and DOWN arrow buttons will function with the "EXCESS SLOPE" light on. The "AUTO LEVEL" button will NOT function if the "EXCESS SLOPE" light is on.

4. Turn the ignition switch to the "OFF" position.

OPERATING PROCEDURES

725 SERIES LEVELING SYSTEM

JACK RETRACTION (HWH TOUCH PANEL CONTROLS)

WARNING: THE OPERATOR MUST BE SURE THAT THERE ARE NO OBJECTS UNDER THE VEHICLE AND THAT ALL PEOPLE ARE CLEAR OF THE VEHICLE.

NOTE: When the jacks are stored with the ignition in the ON position, the warning buzzer will sound until the jacks have retracted to the STORE position. If desired, the jacks can be stored with the ignition key in the accessory position. This will eliminate the warning buzzer while the jacks are retracting.

It is recommended to retract any room extensions before retracting the jacks.

1. Start the engine and press the "AUTO STORE" button. The store indicator light will flash. The vehicle should start to return to proper ride height. The front jacks will retract for 5 seconds before the rear jacks will begin to retract. As each jack retracts, its red WARNING light will go out. The system will automatically shut down 1 minute after the four individual red "WARNING" lights are out. If any one red "WARNING" light does not go out, the system will continue to store for fifty minutes, then shut down regardless of the "WARNING" lights condition.

NOTE: When traveling thermal expansion may cause a jack to extend slightly. When the "AUTO STORE" button has been used to retract the jacks, the system will automatically retract any jack that extends due to thermal expansion.

IMPORTANT: If power to the system is interrupted after starting a store procedure with either the touch panel or the remote rocker switch, the store

procedure should be reinitiated and the jacks should be completely retracted with all four red WARNING lights out prior to traveling.

IMPORTANT: During the Automatic Store procedures, pushing the "AUTO LEVEL", "AUTO STORE" or the "CANCEL" button on the HWH touch panel will stop the automatic store function.

WARNING: DO NOT MOVE THE VEHICLE WHILE THE LEVELING JACKS ARE STILL IN CONTACT WITH THE GROUND OR IN THE EXTEND POSITION. THIS VEHICLE IS EQUIPPED WITH STRAIGHT-ACTING JACKS. MOVING THE VEHICLE WITH THE LEVELING JACKS EXTENDED CAN CAUSE SEVERE DAMAGE TO THE JACKS AND OR THE VEHICLE AND CREATE A DRIVING HAZARD. DO NOT RELY SOLELY UPON WARNING LIGHTS. IT IS THE OPERATOR'S RESPONSIBILITY TO CHECK THAT ALL JACKS ARE FULLY RETRACTED INTO THE STORE/TRAVEL POSITION AND THE VEHICLE IS AT THE PROPER RIDE HEIGHT.

2. The vehicle can be moved as soon as the red warning lights are out, the jacks are in the STORE/TRAVEL position and the green "TRAVEL" light is on, if the vehicle is at the proper ride height for traveling.

IMPORTANT: If a red warning light and buzzer come on while traveling, the jacks should be checked as soon as a safe parking location is found.

3. If jacks cannot be retracted by the above procedure see MANUAL JACK RETRACTION Section.

OPERATING PROCEDURES

MANUAL HYDRAULIC OPERATION

1. Place transmission in the recommended position for parking the vehicle, and set the parking brake. Turn the ignition to the "ACCESSORY" position.
2. Place pads under the jack feet if the ground will not support the vehicle on the jacks.
3. Push the "DUMP" button. Wait until all air is exhausted from the vehicle suspension.
4. The vehicle may be leveled using the manual EXTEND (UP ARROW) buttons on the right half of the panel. If a yellow LEVEL SENSING light is on, that side, end or corner of the vehicle is low. It is best to level the vehicle side to side first, if needed, before front to rear.

Jacks will extend (or retract) in pairs to raise (or lower) a side or end of the vehicle.

Any jack not used for leveling can be extended to the ground. This provides additional stability against wind and activity in the vehicle. Jacks used to stabilize the vehicle after leveling is complete should lift the vehicle slightly after touching the ground.

IMPORTANT: Do not continue to push an EXTEND button for more than ten (10) seconds after that pair of jacks are fully extended.

5. When leveling is completed, turn the ignition switch to the "OFF" position.

MANUAL JACK RETRACTION

The solenoid valves on the power unit valve assembly are equipped with a manual valve release. Use the manual valve release for retracting only if the "AUTO STORE" button on the control panel will not retract the jacks for travel.

NOTE: Assemblies can have different combinations of large and / or small valves.

WARNING: KEEP AWAY FROM THE WHEELS, DO NOT CRAWL UNDER THE VEHICLE, KEEP A SAFE DISTANCE IN FRONT AND REAR OF THE VEHICLE. THE VEHICLE MAY DROP AND/OR MOVE FORWARD OR BACKWARD WITHOUT WARNING AS THE VALVE RELEASE IS OPERATED.

1. Locate the manual valve release on each solenoid valve. The solenoid valves are located on the power unit/valve assembly.

2. Allow clearance for the vehicle to lower.

Large and small valves will be equipped with a valve release cam. The cam might be rotated in any direction on the valve. Pushing the release cam in the wrong direction may damage the valve.

3. Retract the front jacks by slowly opening the two center valves.

4. Repeat the process for the rear jacks by opening the two outer valves.

5. Check that all four jacks are now retracted.

6. Close the valves by moving the valve release cam to the closed position.

7. The system should now be repaired before using again.

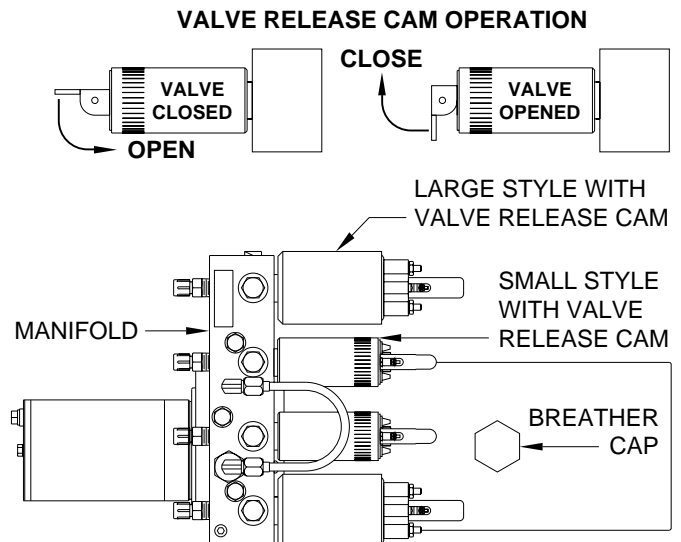

OPERATING PROCEDURES

ROOM EXTEND PROCEDURE

IMPORTANT: Room controls are provided by the vehicle manufacturer. Refer to the vehicle manufacturer for information concerning the room controls. The following information is basic room operating information. Read this information carefully before operating the rooms.

NOTE: The park brake must be set before a room can be extended or retracted.

WARNING: OPERATING A ROOM WITH ANY ROOM LOCKING, CLAMPING OR MANUAL RETRACTING DEVICES ATTACHED OR ENGAGED CAN CAUSE PERSONAL INJURY AND VEHICLE DAMAGE. IT IS THE OPERATOR'S RESPONSIBILITY TO ENSURE THAT ALL ROOM LOCKING, CLAMPING OR MANUAL RETRACTING DEVICES ARE DETACHED OR DISENGAGED BEFORE OPERATING THE ROOM.

Refer to vehicle manufacturer for proper sequence of room extension and leveling system operation.

1. The ignition must be in the "ACC" or "ON" position to operate the room.
2. Unlock all room-locking devices.

NOTE: If a MANUAL RETRACT DEVICE is attached to the room or has been used, remove it before extending the room.

WARNING: KEEP PEOPLE AND OBSTRUCTIONS CLEAR OF ROOM WHEN OPERATING.

NOTE: Make sure there is adequate clearance to fully extend the room.

3. To extend the room, press and hold the ROOM CONTROL in the "EXTEND" position until the room is fully extended.

NOTE: Hold the control to "EXTEND" three or four seconds after the room is fully extended. This assures proper pressurization of the cylinders. **During normal operation of the room, do not reverse direction of the room until the room is fully extended. If necessary, the direction of the room may be reversed, but watch for binding of the room. If the direction of the room has been reversed, DO NOT re-extend the room until the room has been fully retracted.**

IMPORTANT: Do not hold the ROOM CONTROL in the "EXTEND" position for more than ten seconds after the room is fully extended or stops moving. **If either side of the room stops moving, release the room control immediately. DO NOT force the room. DO NOT reverse direction of the room, contact HWH Customer Service for assistance 1-800-321-3494.**

NOTE: Releasing the ROOM CONTROL will halt the operation of the room.

IMPORTANT: Do not use a room extension support when the vehicle is supported by the leveling system.

OPERATING PROCEDURES

ROOM RETRACT PROCEDURE

IMPORTANT: Room controls are provided by the vehicle manufacturer. Refer to the vehicle manufacturer for information concerning the room controls. The following information is basic room operating information. Read this information carefully before operating the rooms.

NOTE: The park brake must be set before a room can be extended or retracted.

WARNING: KEEP PEOPLE AND OBSTRUCTIONS CLEAR OF ROOM WHEN OPERATING.

Refer to vehicle manufacturer for proper sequence of room extension and leveling system operation.

1. The ignition must be in the "ACC" or "ON" position to operate the room.

2. To retract the room press and hold the ROOM CONTROL in the "RETRACT" position until the room is fully retracted.

NOTE: Hold the switch to "RETRACT" three or four seconds after the room is fully retracted. This assures proper pressurization of the cylinders. **During normal operation of the room, do not reverse direction of the room until the room is fully retracted. If necessary, the direction of the room may be reversed, but watch for binding of the room. If the direction of the room has been reversed, DO NOT retract the room until the room has been fully extended.**

IMPORTANT: Do not hold the ROOM CONTROL in the "RETRACT" position for more than ten seconds after the room is fully retracted or stops moving.

If either side of the room stops moving, release the room control immediately. DO NOT force the room. DO NOT reverse direction of the room, contact HWH Customer Service for assistance 1-800-321-3494.

NOTE: Releasing the ROOM CONTROL will halt the operation of the room.

3. Engage all room-locking devices.

4. If the room will not retract see the MANUAL ROOM RETRACT PROCEDURE.

IMPORTANT: Room-locking devices should be locked while traveling.

OPERATING PROCEDURES

MANUAL ROOM RETRACTION PROCEDURES

GENERAL INFORMATION

Most rooms can be retracted manually in the case of a mechanical or electrical failure. Some HWH mechanisms have a built in manual retract mechanism. Some rooms can be retracted through the use of some type of winching mechanism. Some mechanisms, especially with smaller rooms, can simply be pushed in after the solenoid valves have been opened. Refer to other pages in this manual for specific manual room retract information. If information is not available in this manual, contact the vehicle manufacturer or HWH Customer Service for assistance. HWH Customer Service hours are Monday through Friday 8:00AM until 5:00PM Central time.

Note: Contact the vehicle manufacturer for information concerning the storage of any manual retract devices or winches. Refer to the vehicle manufacturer for information to connect a winch or other retract device that is not built into the mechanism. Also contact the vehicle manufacturer for manual room retract procedures for any winch or retracting device not supplied by HWH or in the event no retract device is supplied with the vehicle.

WARNING: USE EXTREME CAUTION WHEN USING A MANUAL RETRACT WINCH.

When manually retracting rooms, it is recommended that leveling jacks be retracted, when possible, before retracting the rooms.

To manually retract a room, it is necessary to determine which extend and retract solenoid valves are assigned to the room. Refer to available diagrams or the vehicle manufacturer for valve location. If the information is not readily available, it is permissible to open all of the room extension valves.

To manually retract a room both the cylinder extend and cylinder retract valves should be opened.

The room extension manifold has valves equipped with valve release nuts or valve release cams.

For valves with release nuts, open the valve by turning the 1/4" release nut counter clockwise. Use a 1/4" nut driver or the nut driver incorporated into the breather cap. **DO NOT turn the release nuts more than 4 and 1/2 turns. Turning the nuts more could damage the valve. When closing the valves, make snug only. DO NOT over tighten the nuts.**

For valves with release cams, simply move the cam to the open position. **The release cam might be rotated in any position on the valve. Moving the cam in the wrong direction can damage the valve.**

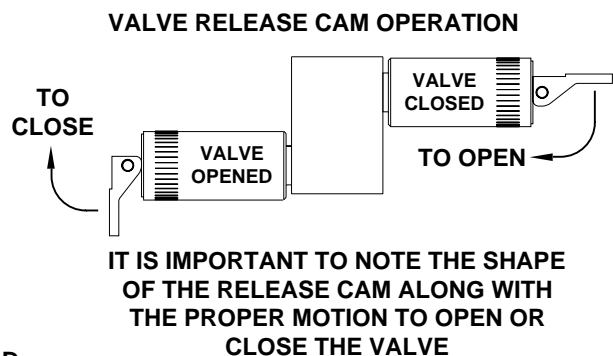
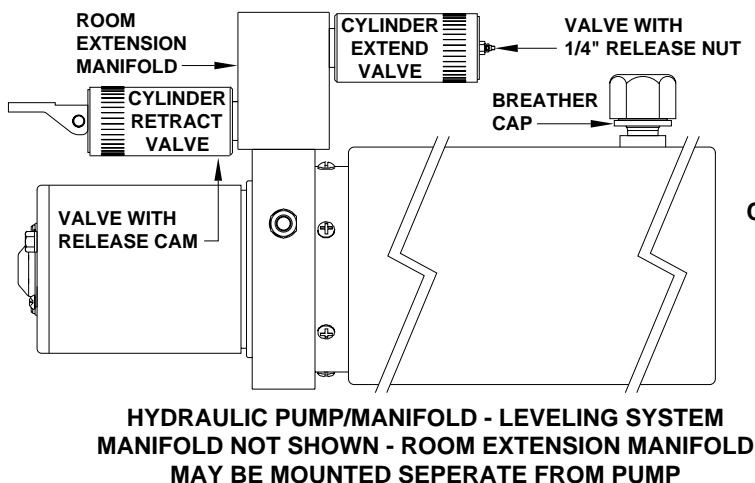

OPERATING PROCEDURES

"UNIVERSAL STRAIGHT OUT" ROOM EXTENSION MECHANISM

MANUAL ROOM RETRACTION PROCEDURES - VALVES WITH RELEASE CAMS

1. Determine which extend and retract solenoid valves are assigned to the room. Manually open the valve release nuts for the extend and retract solenoid valves by moving the valve release cam to the open position.

NOTE: The valve release cam might be rotated in any direction on the valve. Pushing the release cam in the wrong direction could damage the valve.

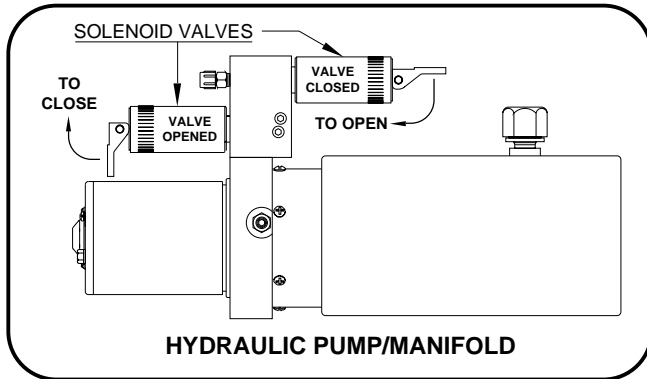

2. Start both threaded rods until resistance is met, one for the front and one for the rear mechanism should be provided.

NOTE: To access the threaded blocks refer to vehicle manufacturer.

3. **Do Not use an impact wrench.** Using wrench provided, a personal wrench or a tire iron with a 1-1/8" opening rotate either mechanism's threaded rod clockwise 6 complete turns.

4. Move to the other room extension mechanism, rotate the threaded rod clockwise 12 complete turns.

5. Return to the first room extension mechanism and rotate the threaded rod clockwise 12 complete turns.

6. Repeat steps 4 and 5 alternating from mechanism to mechanism rotating each threaded rod 12 complete turns until room is sealed. (DO NOT exceed 15 ft.lbs) Make sure the room does not bind.

IMPORTANT: If at any stage something is not understood or if the room begins to bind DO NOT force the room, contact HWH Customer Service for assistance 1-800-321-3494.

NOTE: Leave the solenoid valves open and the threaded rods in place until the room has been serviced.

IMPORTANT: DO NOT EXTEND THE ROOM UNTIL THE ROOM HAS BEEN SERVICED. ANY SOLENOID VALVES LEFT OPEN SHOULD BE CLOSED AND THE THREADED RODS SHOULD BE COMPLETELY REMOVED.

NOTE: If there is not enough room to remove both threaded rods completely, alternate backing the threaded rods out and slightly extending the room. Be careful to not extend the room so far that the threaded rods impact the coach wall or the mechanism.

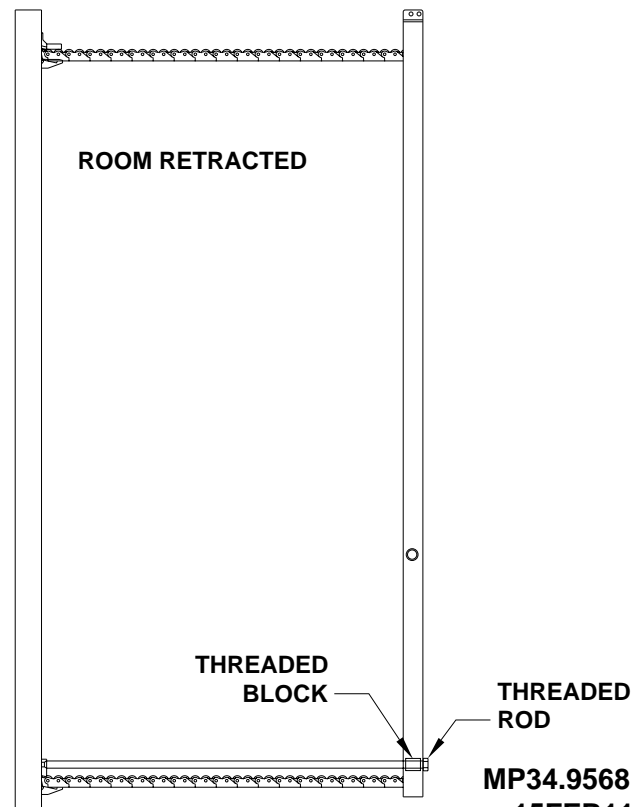
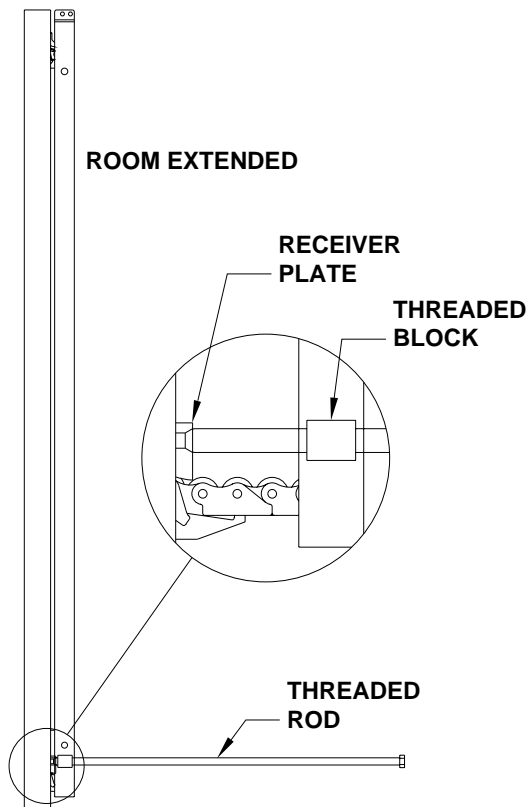

MAINTENANCE

OIL LEVEL

All maintenance should be done as part of the normal servicing of the coach.

The oil level should be checked when the vehicle is first purchased and then once every two years. More often if there is an oil leak in the system.

Any HWH hydraulic equipment, including jacks, slide-outs and steps should be fully retracted before checking fluid level. The oil reservoir is part of the pump / manifold assembly. The oil level is checked and filled through the breather cap. Clear any dirt away from the breather / filler cap before removing.

The oil level should be within one inch of the top of the reservoir. Most breather caps have a dipstick. Fluid level should be between the bottom of the dipstick and the center mark.

NOTE: Overfilling the tank can cause leakage of oil through the breather cap.

FLUID: HWH Specialty Hydraulic Oil is recommended. In an emergency Dexron automatic transmission fluid can be used. **NOTE:** Dexron automatic transmission fluid contains red dye and can cause staining should a leak occur. **DO NOT USE** brake fluid or hydraulic jack fluid. Use of these can damage seals.

ELECTRICAL SYSTEM

The batteries should be in good condition and fully charged. Weak batteries can cause erratic operation. Battery cable terminals and battery posts and connections should be kept clean.

All electrical connections, especially ground connections, should be clean, tight, free from corrosion and protected from weathering.

JACKS

There are very few user serviceable parts on the jacks. The jacks require very little maintenance. If the jacks are extremely dirty with caked on mud they should be washed.

If extremely dirty, the jack rods should NOT be wiped. The jack rods do not need to be oiled or sprayed with anything. See ML47149 for proper maintenance of all jacks.

ROOM EXTENSIONS

The HWH room mechanisms need no maintenance. **DO NOT** grease or lubricate any parts of the HWH mechanism.

Any visible mechanism can be kept clean by washing with water. Refer to the vehicle manufacturer for correct maintenance of the room seals.

VISUAL INSPECTION

Periodically inspect the system for oil leaks and damaged or missing parts, such as pivot bolts or springs. Check the hydraulic lines and wiring for damage and wear. Check that the jacks do not interfere with any parts of the vehicle when they are in the "STORE" position.

The system will operate better if kept clean and free from caked on mud or ice.

OPERATIONAL CHECK

Review the OPERATOR MANUAL. Run the system according to the SYSTEM OPERATION Section. Note any abnormal operation.

Review the "JACK RETRACTION" Section. Make sure the jacks will fully retract to the "STORE" position. Jacks should not interfere with any of the coach when in the "STORE" position.

Check that all lights work according to the "INDICATOR LIGHT" Section. Correct function of the red "WARNING" light is important.

MAINTENANCE

NOT IN PARK/BRAKE CHECK

WARNING: WHEN MAKING THIS CHECK, BLOCK THE COACH WHEELS SECURELY SO THE COACH CANNOT ROLL FORWARD OR BACKWARD.

Apply the brake so the coach cannot roll. Turn the ignition to the "ACC" or "ON" position. Release the parking brake. Push the "AUTO LEVEL" button. The "NOT IN PARK/BRAKE" indicator light should come on while the "AUTO LEVEL" button is pushed. Release the "AUTO LEVEL" button and set the park brake. The leveling system should now function.

If any of the above checks or inspections reveal a problem or if there are other problems or questions, consult a qualified RV repair center, your vehicle or coach manufacturer, or HWH CORPORATION for service or repair.

WINTER WEATHER DRIVING

Anti-icing / deicing agents when splashed on your vehicle, continue to absorb moisture from the air even after they have dried. This can facilitate corrosion of metallic components, such as HWH jacks.

To help reduce the corrosion of jacks after exposure to anti-icing / deicing agents, thoroughly wash jacks with warm soapy water.

INSTRUCTION SHEET

SENSING UNIT MAINTENANCE/SERVICE

REMOTE MOUNTED "POTTED" ELECTRONIC SENSING UNIT

SENSING UNIT ACCURACY TOLERANCE

The sensing unit has an accuracy tolerance of ± 5.4 inches front to rear and ± 1 inch side to side on a 36 foot vehicle. Typical leveling results will be better.

SENSING UNIT ADJUSTMENT / WITH ADJUSTING ENHANCEMENT

Level the vehicle by placing a bubble level in the center of the freezer floor or upon whichever surface within the vehicle that is to be level. It is best if the level is placed close to the mounting area of the sensing unit. Using the Leveling System and the bubble level, ignoring the yellow LEVEL lights on the Touch Panel, level the vehicle until the bubble is centered.

With the vehicle level according to the bubble level, if there are no yellow lights lit on the Touch Panel, the sensing unit is properly adjusted. If there are yellow LEVEL lights lit on the Touch Panel, manual adjustments to the Sensing Unit are needed.

The ignition (motorized units) or master power switch (towable units) must be on. Remove the "Adjusting Enhancement Cap". **DO NOT LOSE THIS CAP.** There is a small pin beneath the cap. Use a jumper wire with an alligator clip to apply a ground to the pin. This will make the sensing unit very sensitive. The yellow lights may "jump" around while adjusting the sensing unit. Let the lights settle down after each adjustment. Small, gentle turns will work best. Turn mounting screws 1 and 3 to adjust the sensing unit. Turn screws as instructed to turn out all the yellow LEDs. When all the LEDs are out, remove the jumper wire and replace the adjusting enhancement cap. **DO NOT** over tighten.

Move the vehicle to an unlevel position and level the vehicle according to the yellow level sensing lights on the touch panel. Readjust if necessary.

IMPORTANT: THE SENSING UNIT MOUNTING SPRINGS SHOULD BE COMPRESSED ABOUT 1/2 THEIR FREE LENGTH. SCREW NUMBER 2 SHOULD NOT BE TURNED WHILE ADJUSTING THE SENSING UNIT. AFTER ADJUSTING THE SENSING UNIT, BUMP THE SENSING UNIT TO SEE THAT IT IS SETTLED TIGHT AGAINST ALL THREE SCREW HEADS AND STILL INDICATES THAT THE UNIT IS LEVEL.

NOTE: If opposing LED's are lit, there is a problem with the Sensing Unit.

If LED (A) is lit: Tighten adjustment screw number 1 until the LED is off.

If LED (C) is lit: Loosen adjustment screw number 1 until the LED is off.

If LED (B) is lit: Loosen adjustment screw number 3 until the LED is off.

If LED (D) is lit: Tighten adjustment screw number 3 until the LED is off.

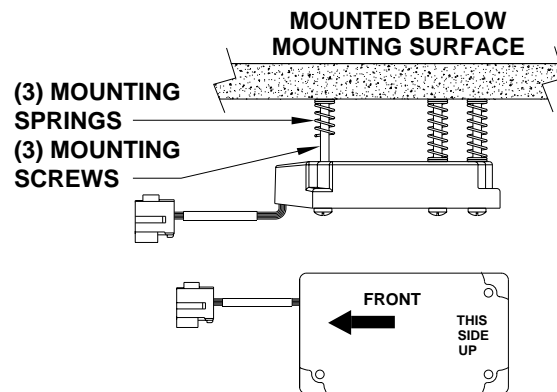
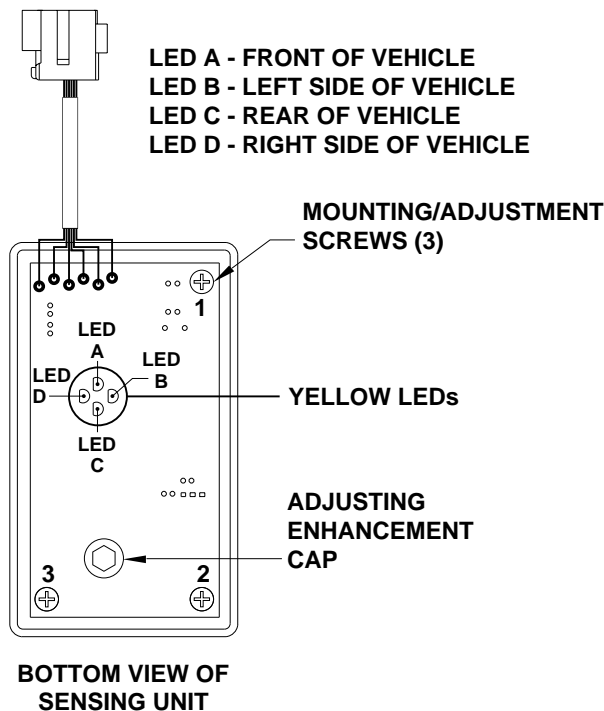

HYDRAULIC LINE CONNECTION DIAGRAM

625/725 SERIES LEVELING SYSTEM

(WITH 4 STRAIGHT-ACTING JACKS)

MANIFOLDS MAY HAVE FOUR (4) LARGE VALVES OR FOUR (4) SMALL VALVES

NOTE: BEFORE OPERATING MANUAL VALVE RELEASE, READ AND UNDERSTAND PROCEDURE FOR MANUAL JACK RETRACTION IN OPERATOR'S INSTRUCTIONS. VALVES MAY BE EQUIPPED WITH VALVE RELEASE NUTS OR RELEASE CAMS.

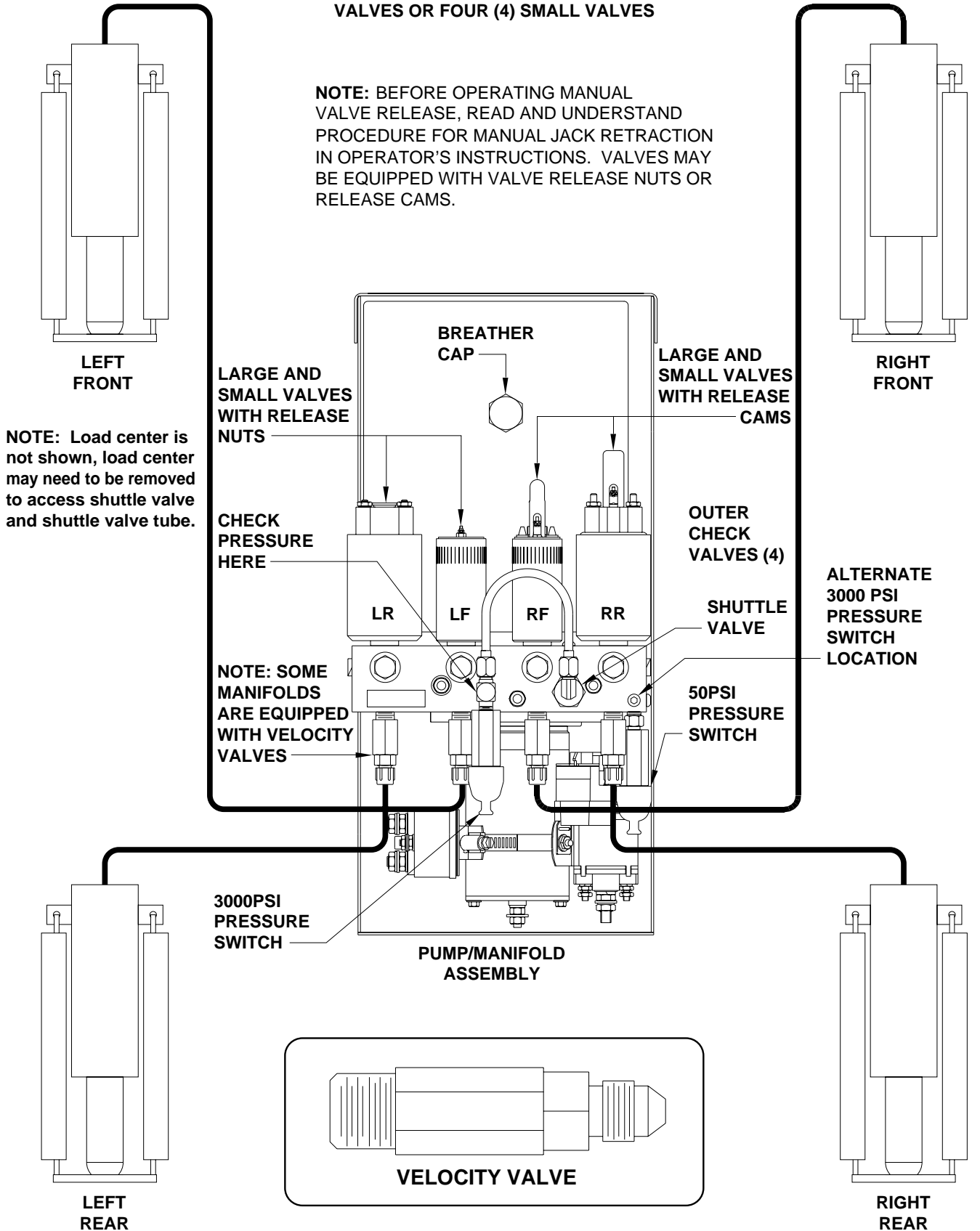

HYDRAULIC SCHEMATIC DIAGRAM

BI-AXIS LEVELING WITH STRAIGHT-ACTING JACKS

625, 625S OR 725 SERIES

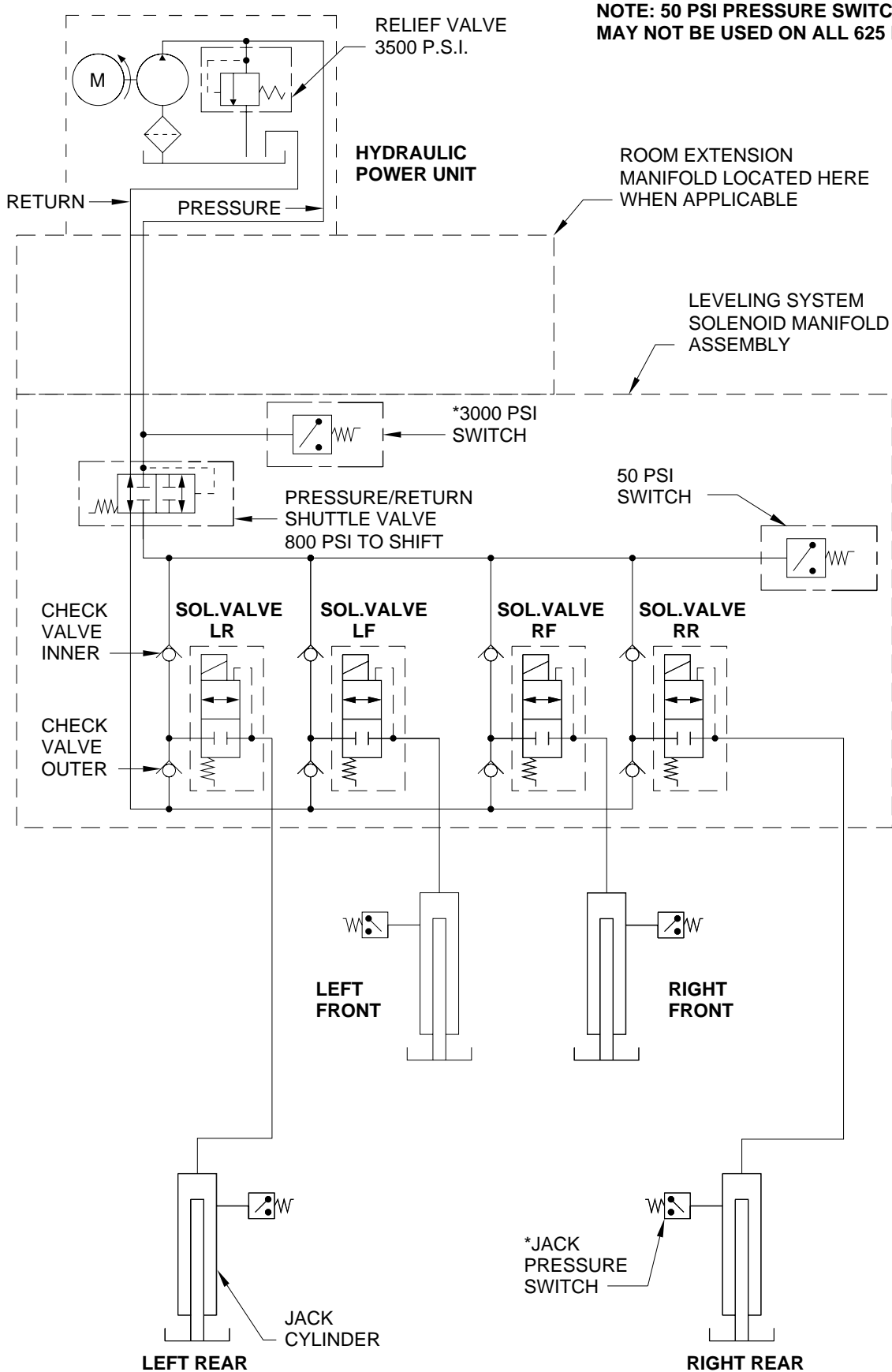

* USED ON AUTOMATIC SYSTEMS ONLY

MP64.4530
29MAR10

HYDRAULIC LINE CONNECTION DIAGRAM

MULTIPLE EXTENSIONS

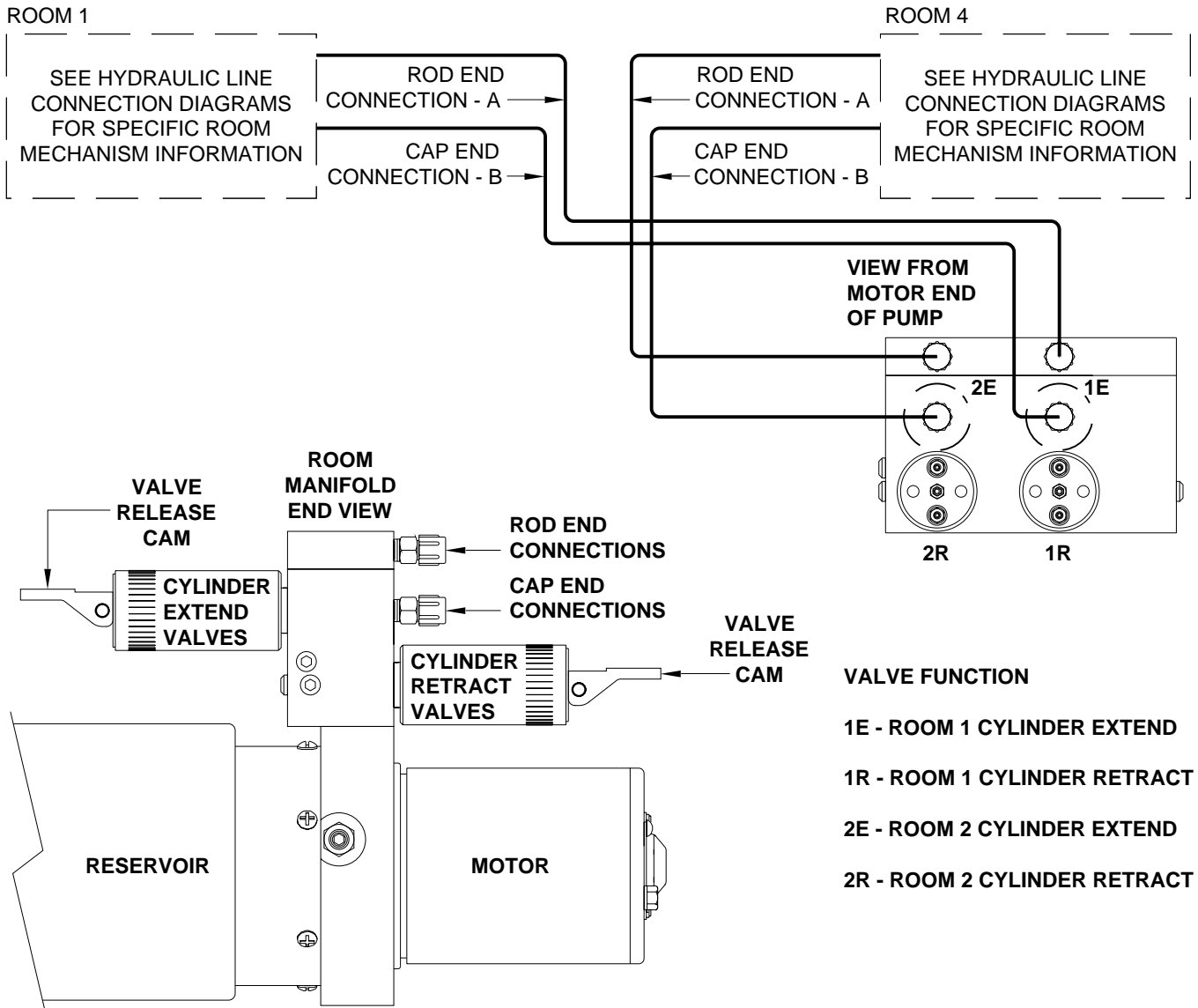

NOTE: SHOWN WITH ROOM EXTENSION MANIFOLD ONLY. THE LEVELING SYSTEM MANIFOLD (NOT SHOWN) IS MOUNTED ON TOP OF THE ROOM EXTENSION MANIFOLD.

NOTE: THIS VEHICLE MAY BE EQUIPPED WITH TWO IN-FLOOR LEVEL OUT (IFLO) ROOM MECHANISMS OR ONE IN-FLOOR LEVEL OUT (IFLO) ROOM MECHANISM AND ONE UNIVERSAL STRAIGHT OUT (USO) ROOM MECHANISM.

HYDRAULIC LINE CONNECTION DIAGRAM DUAL CYLINDER "IN FLOOR" ROOM EXTENSION (WITH SYNCHRONIZING CYLINDER)

DUAL CYLINDER "IN FLOOR" ROOM EXTENSION
(WITH SYNCHRONIZING CYLINDER)

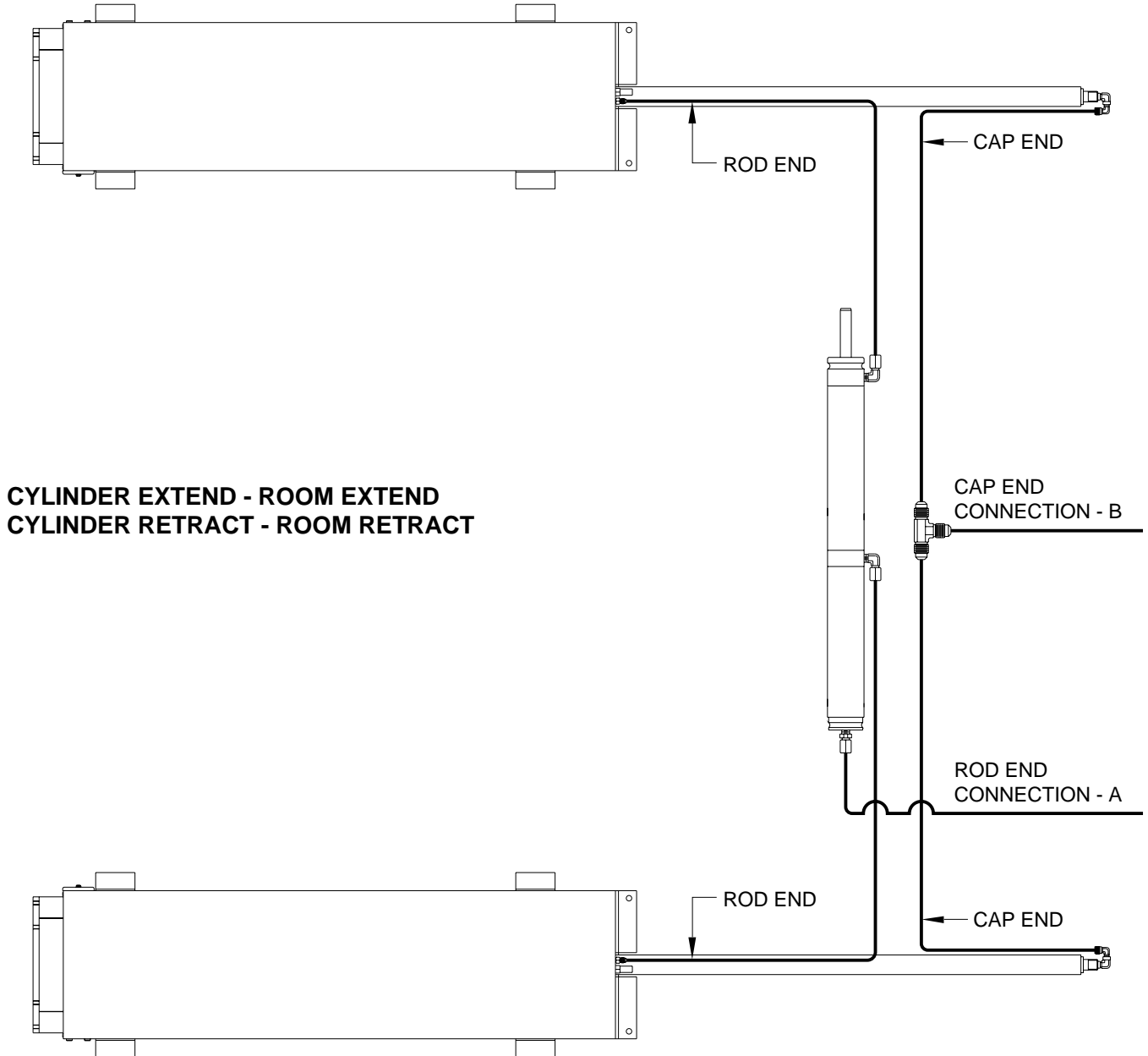

HYDRAULIC LINE CONNECTION DIAGRAM UNIVERSAL (USO) ROOM EXTENSION (WITH SYNCHRONIZING CYLINDER)

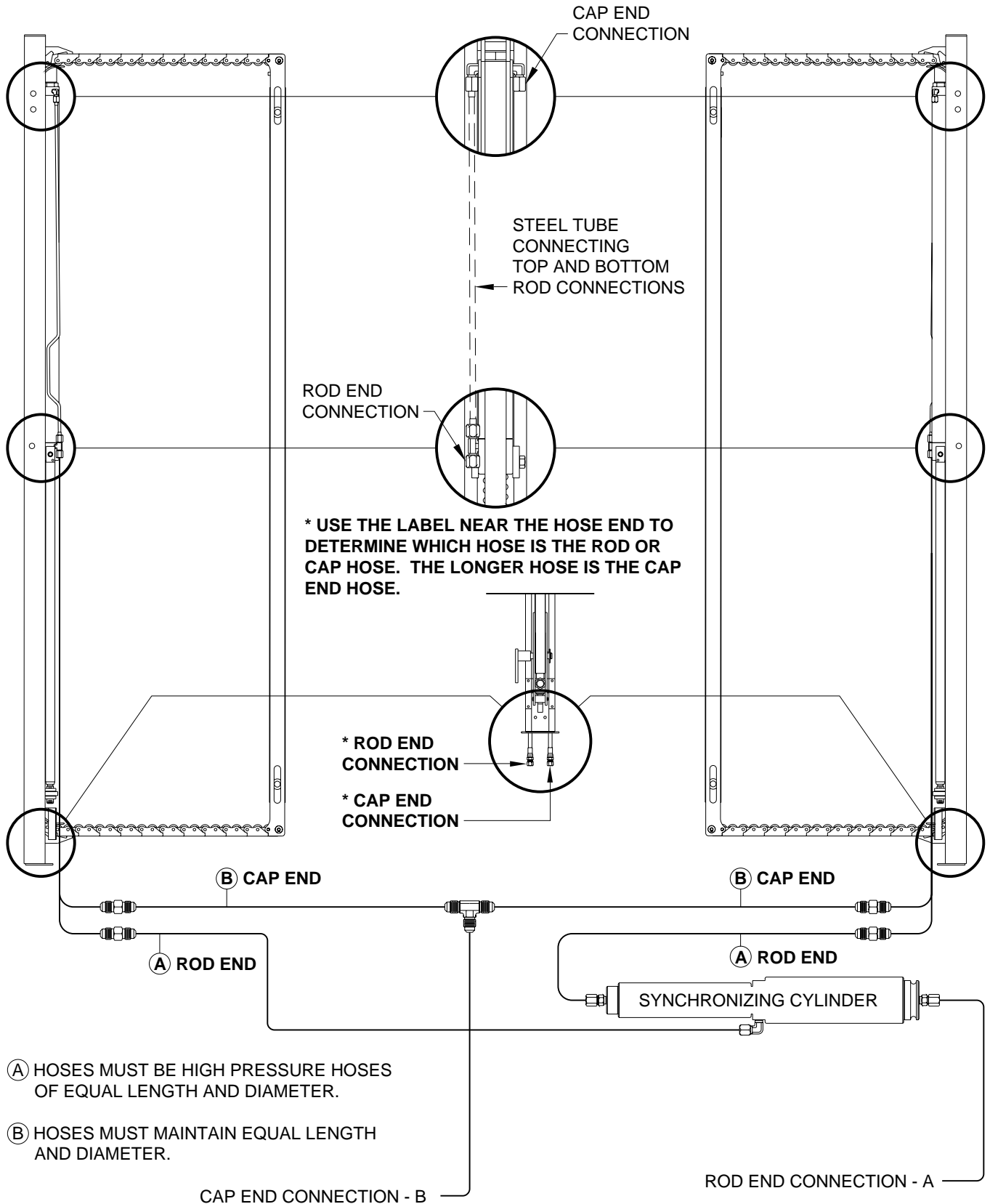

(A) HOSES MUST BE HIGH PRESSURE HOSES OF EQUAL LENGTH AND DIAMETER.

(B) HOSES MUST MAINTAIN EQUAL LENGTH AND DIAMETER.

**CYLINDER EXTEND - ROOM RETRACT
CYLINDER RETRACT - ROOM EXTEND
CHECK OIL LEVEL WITH ROOM EXTENDED**

ELECTRICAL CONNECTION DIAGRAM

725 SERIES SINGLE STEP LEVELING SYSTEM W/PILOT AIR DUMP JACK WARNING SWITCHES AND PRESSURE SWITCHES

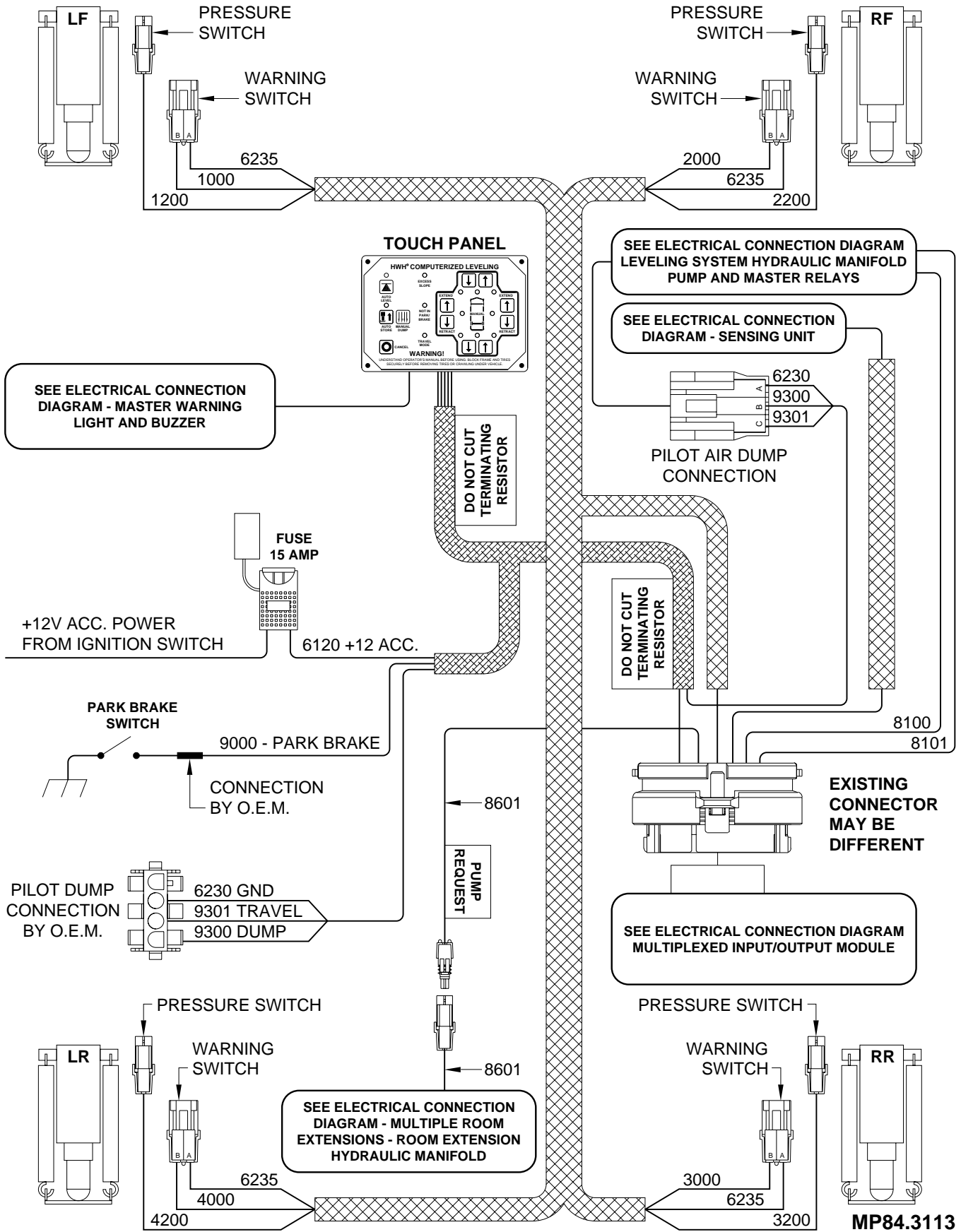

ELECTRICAL CONNECTION DIAGRAM

MULTIPLEXED INPUT/OUTPUT MODULE - BLACK STRIKE CONNECTOR

LED AND WIRE/CONNECTION INFORMATION

NOTE: DUMP AND TRAVEL LEDS PRESENT BUT NOT ALWAYS USED

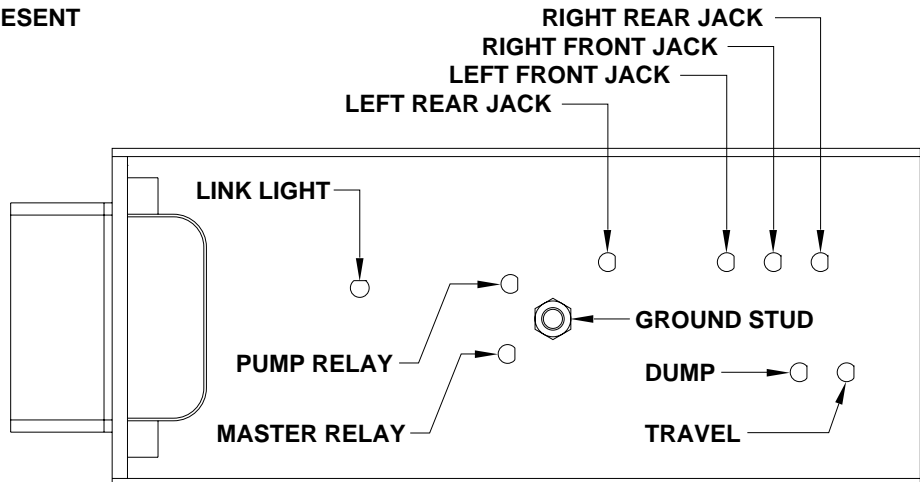

FRONT VIEW OF I/O MODULE CONNECTOR

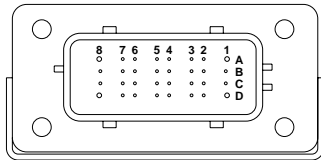

A LIT RED LED INDICATES THERE SHOULD BE +12 VOLTS ON THE CORRESPONDING WIRE.

LINK LIGHT: LINK LIGHT FLASHING INDICATES PROPER COMMUNICATION BETWEEN THE I/O MODULE AND THE TOUCH PANEL. LINK LIGHT ON SOLID OR OFF INDICATES A FAILURE.

PIN #	WIRE COLOR	WIRE NUMBER	WIRE DESCRIPTION AND FUNCTION
A1	(+12 BLACK WIRE 8601)	INPUT WHEN EXTENSION DEVICES ROOMS, GEN SLIDE, STEP COVER, ETC. ARE USED	
A2	YELLOW	N/A	CAN HIGH COMMUNICATION WIRE
A3 AND A4			NO CONNECTION
A5	BLACK	2000	SWITCHED GROUND FROM RIGHT FRONT JACK WARNING SWITCH
A6	BLACK	2200	SWITCHED GROUND FROM RIGHT FRONT JACK PRESSURE SWITCH
A7	BLACK	3200	SWITCHED GROUND FROM RIGHT REAR JACK PRESSURE SWITCH
A8	BLACK	8101	SWITCHED GROUND FROM 50 PSI MANIFOLD PRESSURE SWITCH
B1	RED	6800	+12 VOLT POWER TO THE TOUCH PANEL
B2	GREEN	N/A	CAN LOW COMMUNICATION WIRE
B3	WHITE	6230	GROUND TO THE TOUCH PANEL
B4			NO CONNECTION
B5	BLACK	3000	SWITCHED GROUND FROM RIGHT REAR JACK WARNING SWITCH
B6	BLACK	4200	SWITCHED GROUND FROM LEFT REAR JACK PRESSURE SWITCH
B7			NO CONNECTION
B8	BLACK	8100	SWITCHED GROUND FROM 3000 PSI MANIFOLD PRESSURE SWITCH
C1	RED	6121	+12 VOLT POWER FOR LEVEL SENSING UNIT
C2	N/A	N/A	SHIELD WIRE FOR GREEN & YELLOW CAN COMMUNICATION WIRES
C3	WHITE	6231	GROUND FOR LEVEL SENSING UNIT
C4	BLACK	0400	SWITCHED GROUND FROM SENSING UNIT - REAR
C5	BLACK	4000	SWITCHED GROUND FROM LEFT REAR JACK WARNING SWITCH
C6 AND C7			NO CONNECTION
C8	BLACK	0300	SWITCHED GROUND FROM SENSING UNIT - RIGHT SIDE
D1	RED	6120	+12 VOLT ACCESSORY POWER FOR I/O MODULE
D2	WHITE	6235	GROUND FOR JACK WARNING SWITCHES
D3			NO CONNECTION
D4	BLACK	1000	SWITCHED GROUND FROM LEFT FRONT JACK WARNING SWITCH
D5	BLACK	1200	SWITCHED GROUND FROM LEFT FRONT JACK PRESSURE SWITCH
D6	BLACK	0100	SWITCHED GROUND FROM SENSING UNIT - LEFT SIDE
D7	BLACK	0200	SWITCHED GROUND FROM SENSING UNIT - FRONT
D8	BLACK	9000	GROUND FROM PARK BRAKE SWITCH

ELECTRICAL CONNECTION DIAGRAM

MULTIPLEXED INPUT/OUTPUT MODULE - GRAY AMPSEAL CONNECTOR

LED AND WIRE/CONNECTION INFORMATION

NOTE: DUMP AND TRAVEL LEDS PRESENT BUT NOT ALWAYS USED

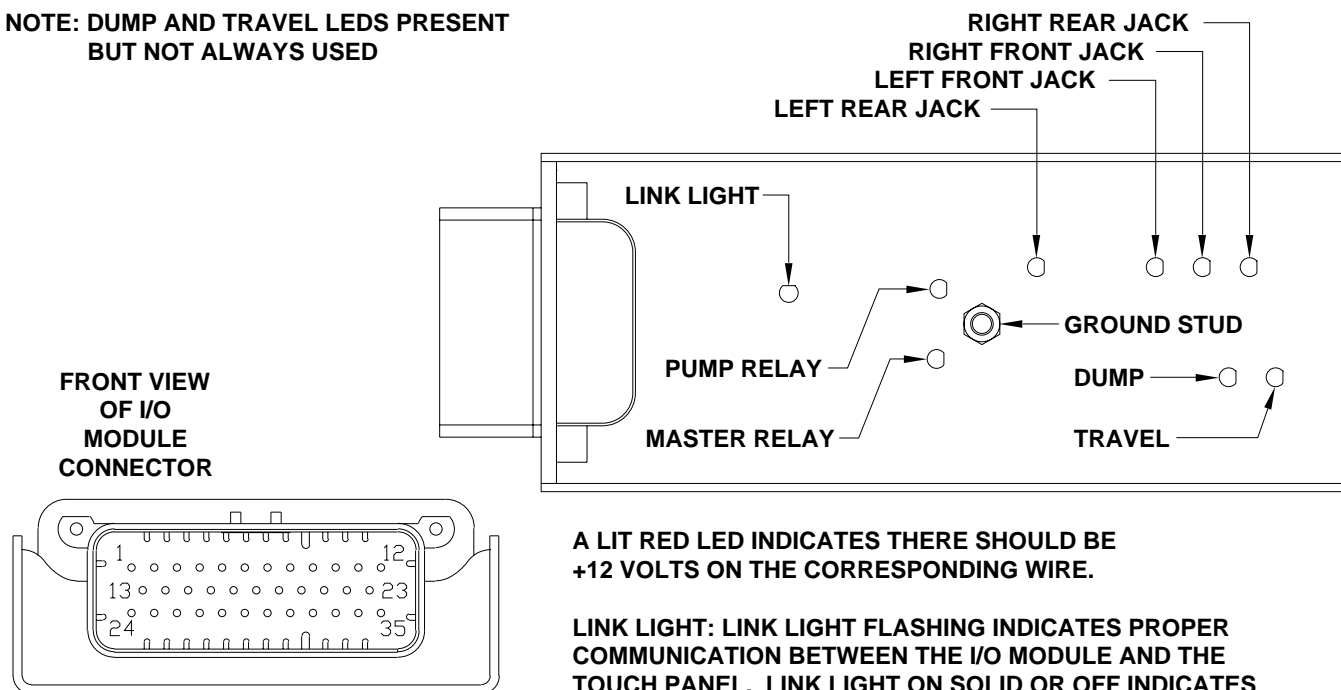

PIN #	WIRE COLOR	WIRE NUMBER	WIRE DESCRIPTION AND FUNCTION
1	BLACK	9000	GROUND FROM PARK BRAKE SWITCH
2			NO CONNECTION
3	BLACK	8101	SWITCHED GROUND FROM 50 PSI MANIFOLD PRESSURE SWITCH
4	BLACK	0100	SWITCHED GROUND FROM SENSING UNIT - LEFT SIDE
5	BLACK	0400	SWITCHED GROUND FROM SENSING UNIT - REAR
6	BLACK	3000	SWITCHED GROUND FROM RIGHT REAR JACK WARNING SWITCH
7	BLACK	2200	SWITCHED GROUND FROM RIGHT FRONT JACK PRESSURE SWITCH
8			NO CONNECTION
9	BLACK	8601	+12 FOR PUMP REQUEST - SLIDE-OUTS, GEN SLIDE, STEP, ETC.
10			NO CONNECTION
11	WHITE	6235	GROUND FOR JACK DOWN WARNING SWITCHES
12 THRU 15			NO CONNECTION
16	BLACK	0300	SWITCHED GROUND FROM SENSING LIGHT - RIGHT SIDE
17	BLACK	2000	SWITCHED GROUND FROM RIGHT FRONT JACK WARNING SWITCH
18	BLACK	1200	SWITCHED GROUND FROM LEFT FRONT JACK PRESSURE SWITCH
19			NO CONNECTION
20	WHITE	6230	GROUND TO THE TOUCH PANEL
21	N/A	N/A	SHIELD WIRE FOR GREEN & YELLOW CAN COMMUNICATION WIRES
22	YELLOW		CAN HIGH COMMUNICATION WIRE
23	GREEN		CAN LOW COMMUNICATION WIRE
24			NO CONNECTION
25	BLACK	4200	SWITCHED GROUND FROM LEFT REAR JACK PRESSURE SWITCH
26	BLACK	8100	SWITCHED GROUND FROM 3000 PSI MANIFOLD PRESSURE SWITCH
27	BLACK	0200	SWITCHED GROUND FROM SENSING UNIT - FRONT
28	BLACK	1000	SWITCHED GROUND FROM LEFT FRONT JACK WARNING SWITCH
29	BLACK	4000	SWITCHED GROUND FROM LEFT REAR JACK WARNING SWITCH
30	BLACK	3200	SWITCHED GROUND FROM RIGHT REAR JACK PRESSURE SWITCH
31			NO CONNECTION
32	WHITE	6231	GROUND FOR LEVEL SENSING UNIT
33	RED	6121	+12 VOLT POWER FOR LEVEL SENSING UNIT
34	RED	6800	+12 VOLT POWER TO THE TOUCH PANEL
35	RED	6120	+12 VOLT ACCESSORY POWER FOR THE I/O MODULE

ELECTRICAL CONNECTION DIAGRAM

LEVELING SYSTEM HYDRAULIC MANIFOLD W/PILOT AIR DUMP PUMP AND MASTER RELAYS

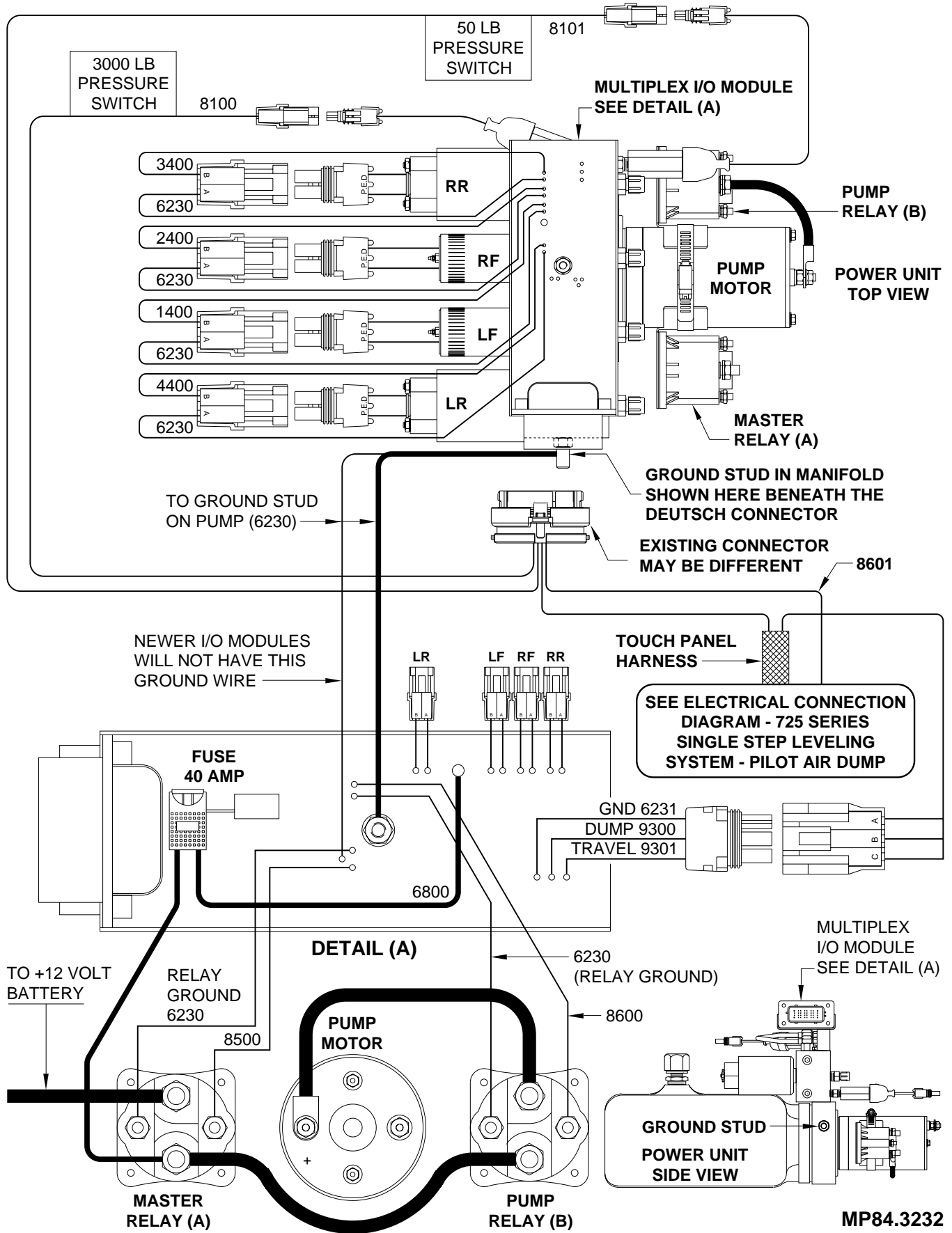

ELECTRICAL CONNECTION DIAGRAM

TWO IN-FLOOR LEVEL OUT (IFLO) ROOM EXTENSIONS

ROOM EXTENSION HYDRAULIC MANIFOLD

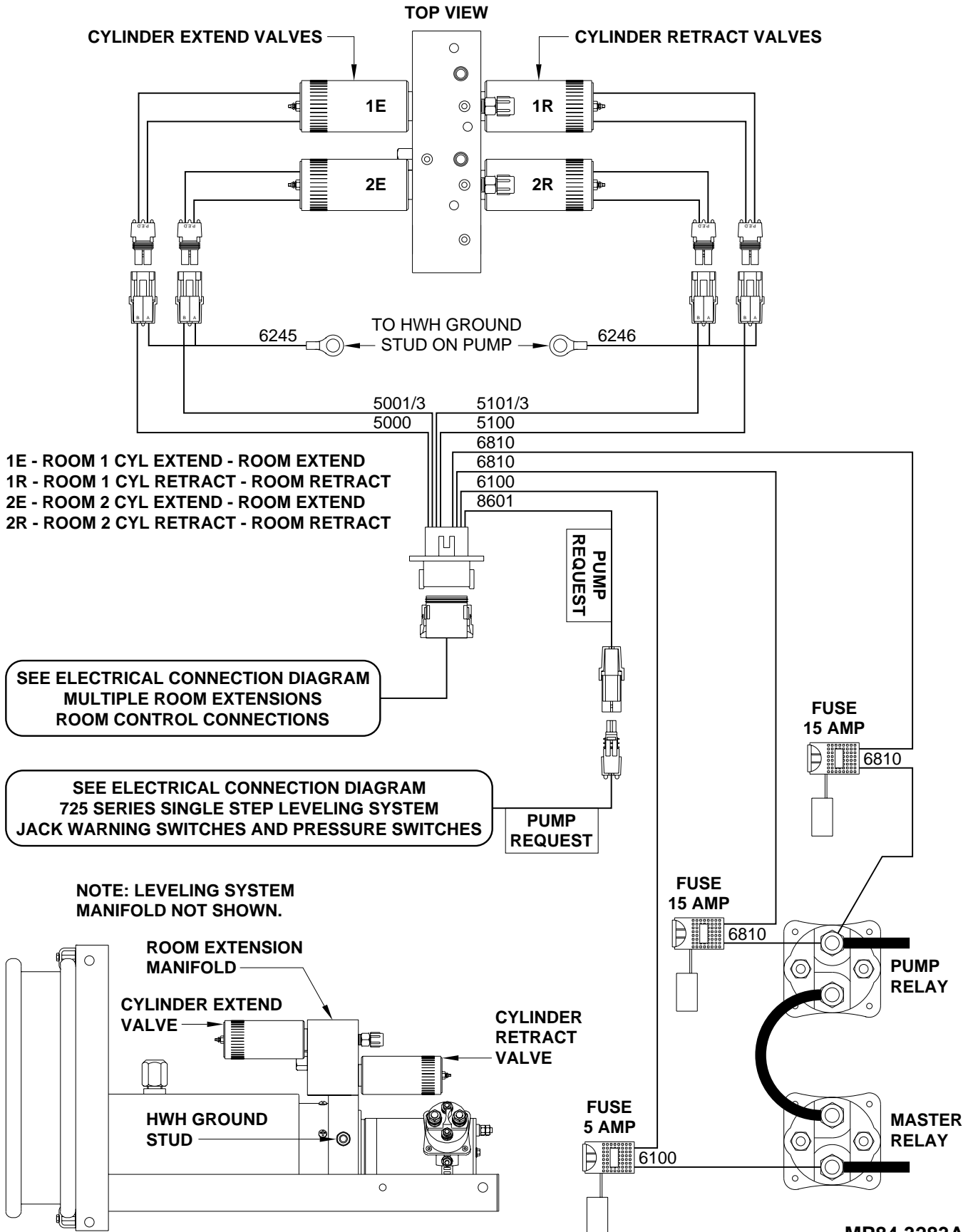

ELECTRICAL CONNECTION DIAGRAM ONE IN-FLOOR LEVEL OUT (IFLO) AND ONE UNIVERSAL STRAIGHT-OUT (USO) ROOM EXTENSIONS ROOM EXTENSION HYDRAULIC MANIFOLD

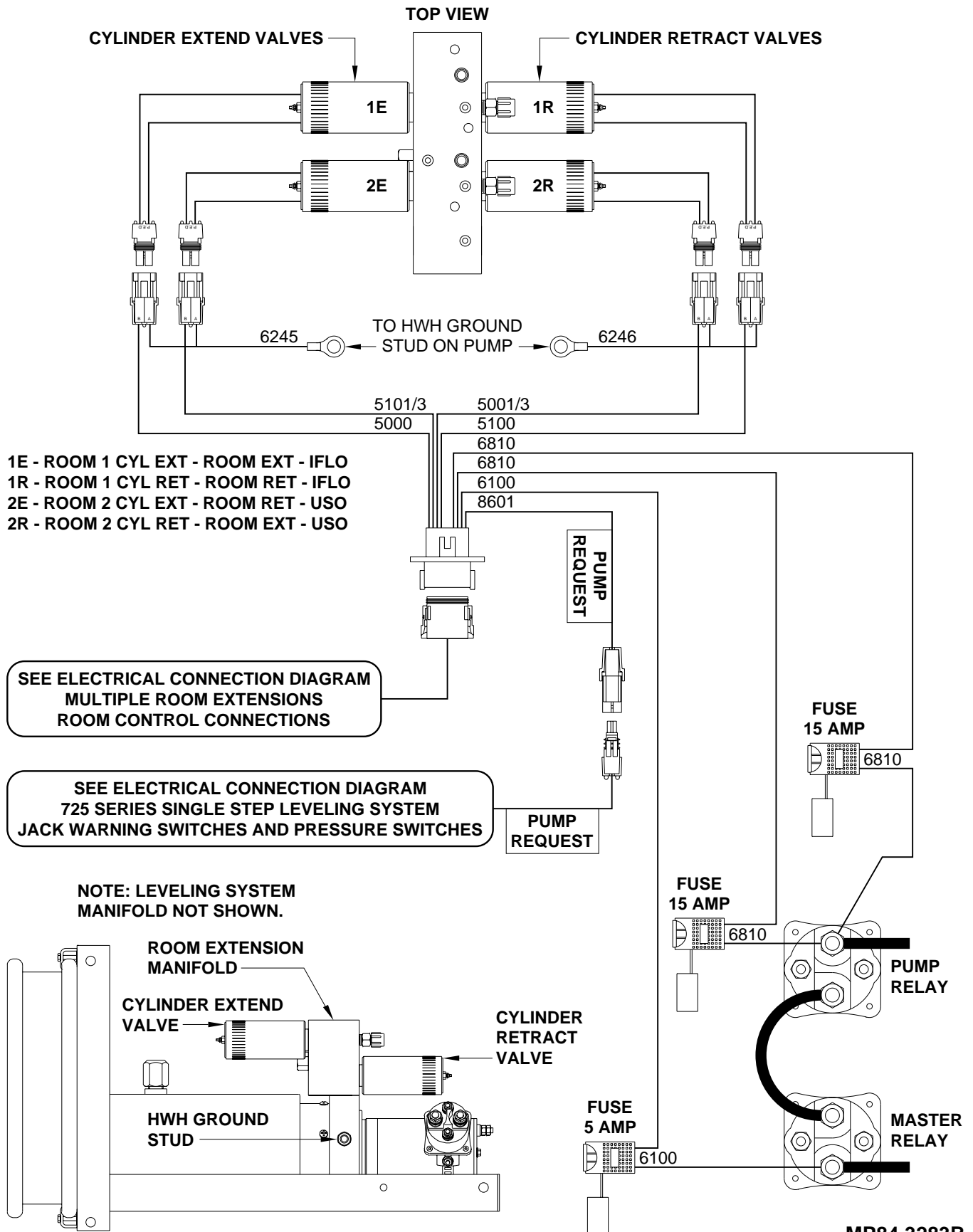

ELECTRICAL CONNECTION DIAGRAM

725 LEVELING SYSTEM

TOUCH PANEL CONNECTIONS

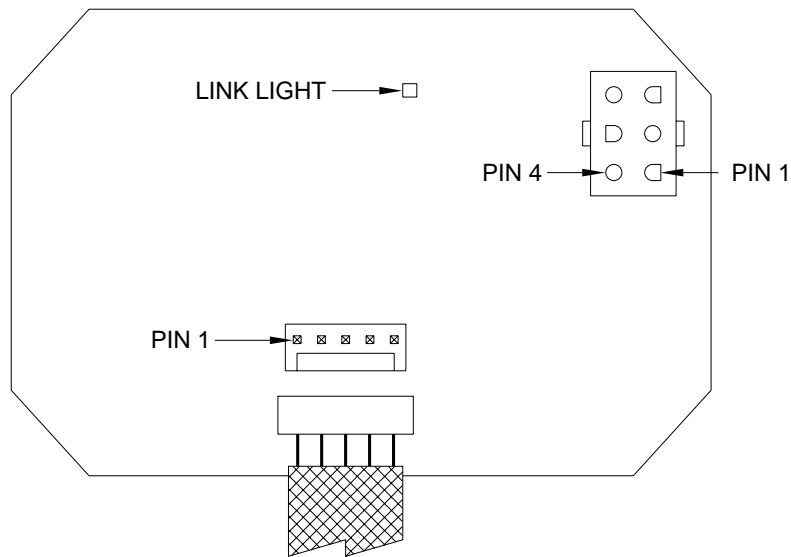
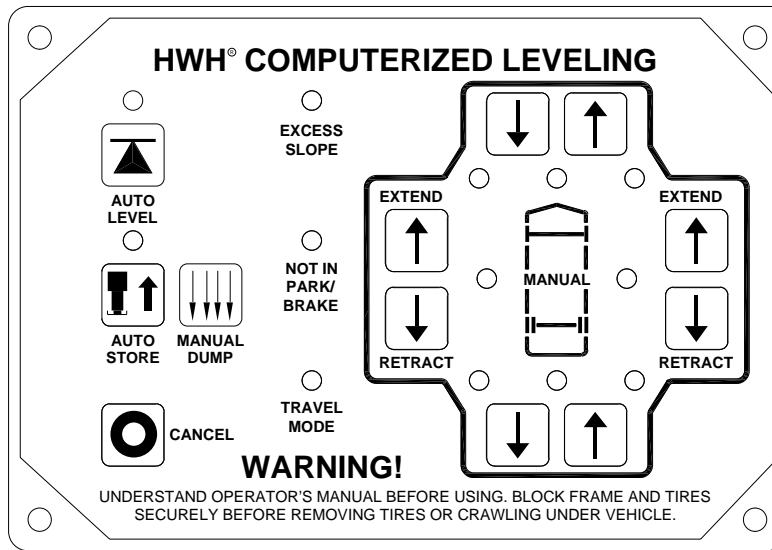

PIN #	WIRE COLOR	WIRE NUMBER	WIRE DESCRIPTION AND FUNCTION
5 PIN MTA CONNECTOR			
1	YELLOW	---	CAN HIGH
2	GREEN	---	CAN LOW
3	---	---	CAN SHIELD
4	WHITE	6230	GROUND FROM CONTROL BOX
5	RED	6800	+12 VOLTS FROM INPUT/OUTPUT MODULE
6 PIN UML CONNECTOR			
1 THRU 4	---	---	NO CONNECTION
5	BLACK	7699	SWITCHED GROUND FOR MASTER WARNING
6	---	---	NO CONNECTION

ELECTRICAL CONNECTION DIAGRAM

TWO ROOM EXTENSIONS

ROOM CONTROL CONNECTIONS

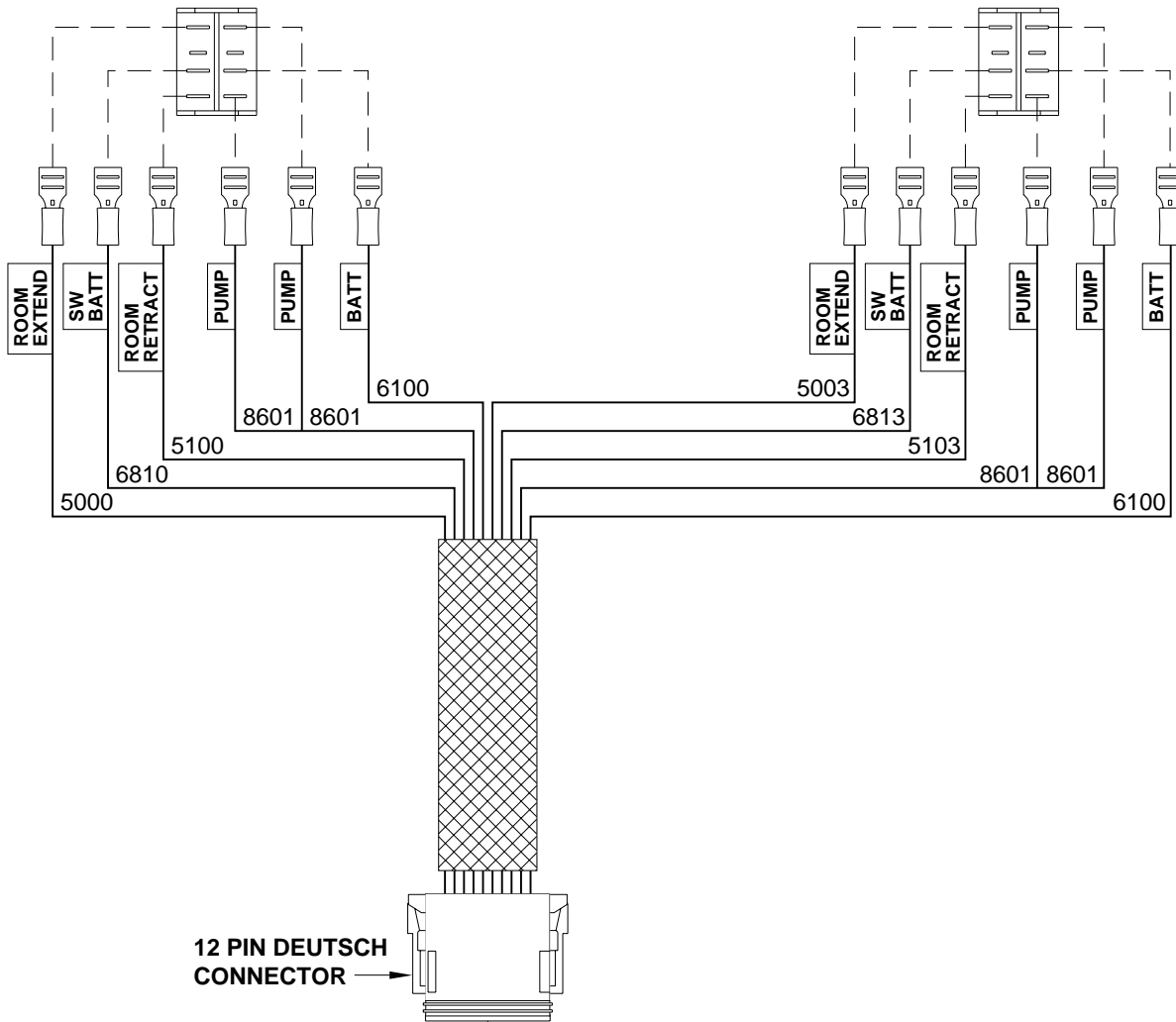

12 PIN DEUTSCH
CONNECTOR

12 PIN DEUTSCH CONNECTOR

- PIN 1 - BLACK 6810 - SWITCHED +12 FROM PUMP RELAY FOR ROOM 1
- PIN 2 - BLACK 5000 - SWITCHED +12 FOR ROOM 1 EXT. VALVE
- PIN 3 - BLACK 5100 - SWITCHED +12 FOR ROOM 1 RET. VALVE
- PIN 4 - BLACK 6813 - SWITCHED +12 FROM PUMP RELAY FOR ROOM 4
- PIN 5 - BLACK 5003 - SWITCHED +12 FOR ROOM 4 EXTEND VALVE
- PIN 6 - BLACK 5103 - SWITCHED +12 FOR ROOM 4 RETRACT VALVE
- PIN 7 - NO CONNECTION
- PIN 8 - KEY PIN
- PIN 9 - NO CONNECTION
- PIN 10 - BLACK 8601 - SWITCHED +12 FOR PUMP CONTROL
- PIN 11 - RED 6100 - +12 BATTERY FROM MASTER RELAY
- PIN 12 - KEY PIN

SEE ELECTRICAL CONNECTION DIAGRAM
TWO ROOM EXTENSIONS
ROOM EXTENSION HYDRAULIC MANIFOLD

ELECTRICAL CONNECTION DIAGRAM

LEVEL SENSING UNIT

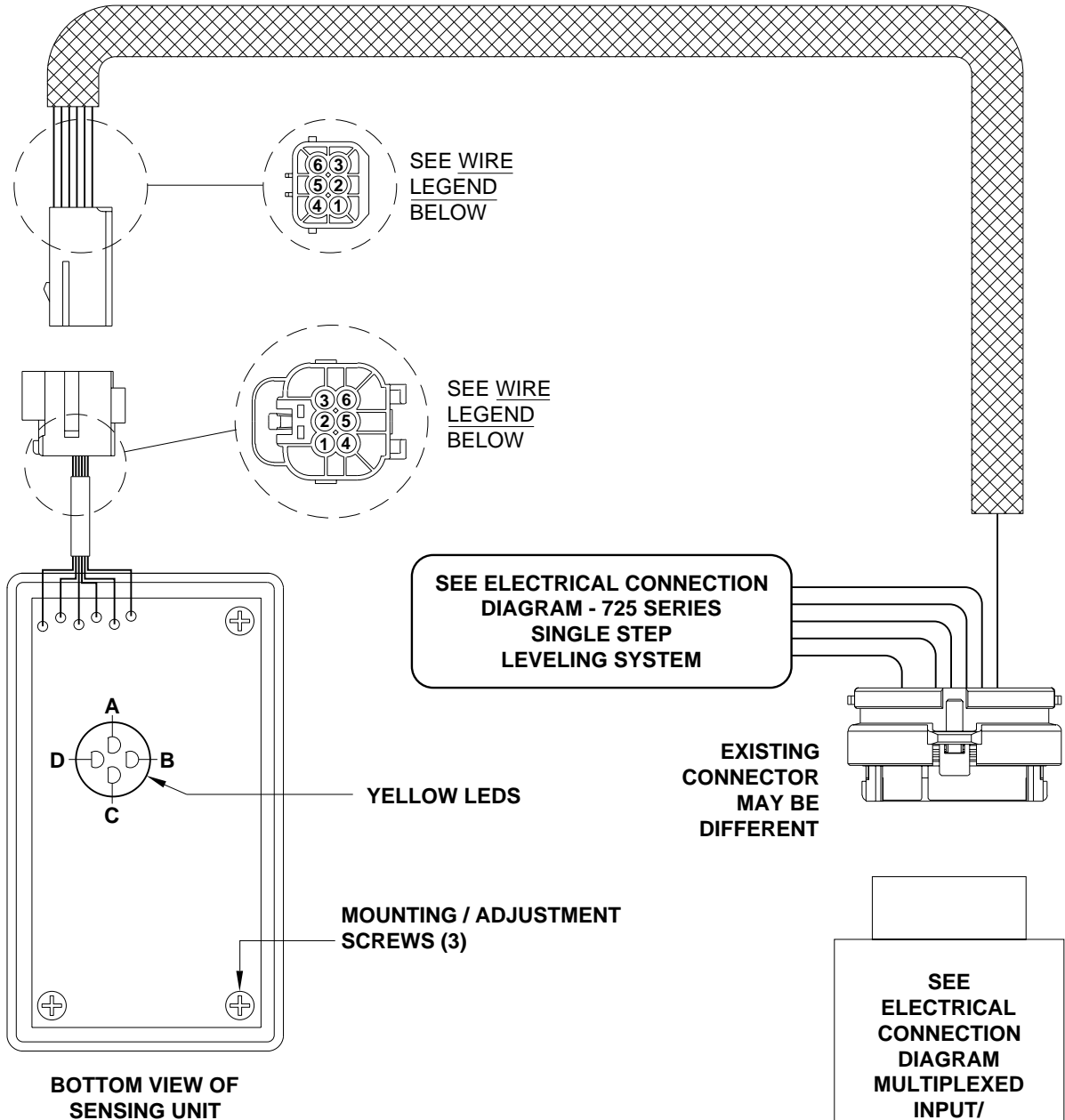

BOTTOM VIEW OF SENSING UNIT

- LED A - FRONT OF VEHICLE
- LED B - LEFT SIDE OF VEHICLE (DRIVER SIDE)
- LED C - REAR OF VEHICLE
- LED D - RIGHT SIDE OF VEHICLE (PASSENGER SIDE)

WIRE LEGEND -

SENSING UNIT PLUG	HARNESS PLUG	
PIN 1 - ORANGE	BLACK - 0400	SWITCHED GROUND WHEN REAR IS LOW
PIN 2 - WHITE	WHITE - 6231	GROUND FROM SENSING UNIT
PIN 3 - RED	RED - 6121	+12 VOLT FOR SENSING UNIT
PIN 4 - YELLOW	BLACK - 0100	SWITCHED GROUND WHEN LEFT SIDE IS LOW
PIN 5 - BLACK	BLACK - 0200	SWITCHED GROUND WHEN FRONT IS LOW
PIN 6 - GREEN	BLACK - 0300	SWITCHED GROUND WHEN RIGHT SIDE IS LOW

ELECTRICAL CONNECTION DIAGRAM MASTER WARNING LIGHT AND BUZZER

A MASTER WARNING INDICATOR SHOULD ALWAYS BE USED. WHEN THE LEVELING SYSTEM HAS STRAIGHT-ACTING JACKS A WARNING BUZZER MUST BE USED.

NOTE: BY SUPPLYING IGNITION POWER TO THE WARNING BUZZER AND LIGHT, AND "ACC" POWER TO THE CONTROL BOX, THE SYSTEM MAY BE OPERATED IN ACCESSORY WITHOUT THE BUZZER SOUNDING. THE NEGATIVE SIGNAL FOR THE WARNING INDICATORS MUST ALWAYS COME FROM THE CONTROL BOX.

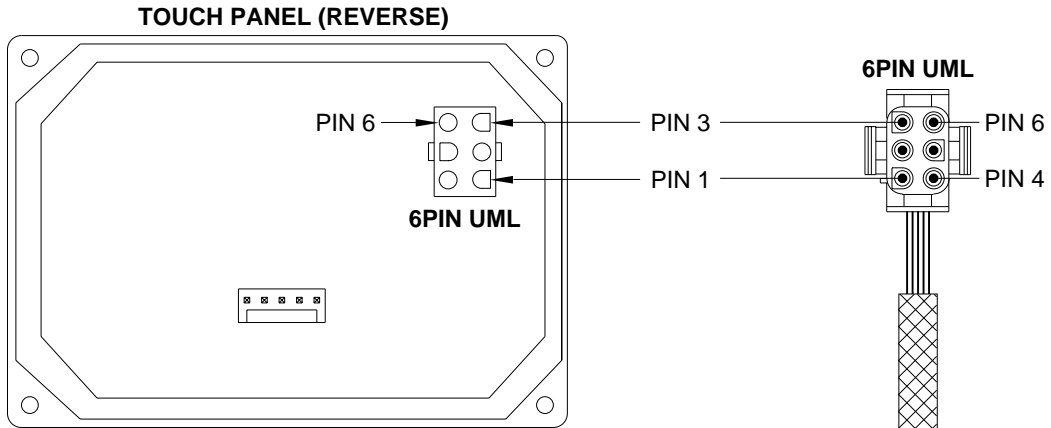

6 PIN UML CONNECTOR

- PINS 1 THRU 4 - NO CONNECTION
- PIN 5 - SW GND CONTROL FOR MASTER WARNING LIGHT & BUZZER
- PIN 6 - NO CONNECTION

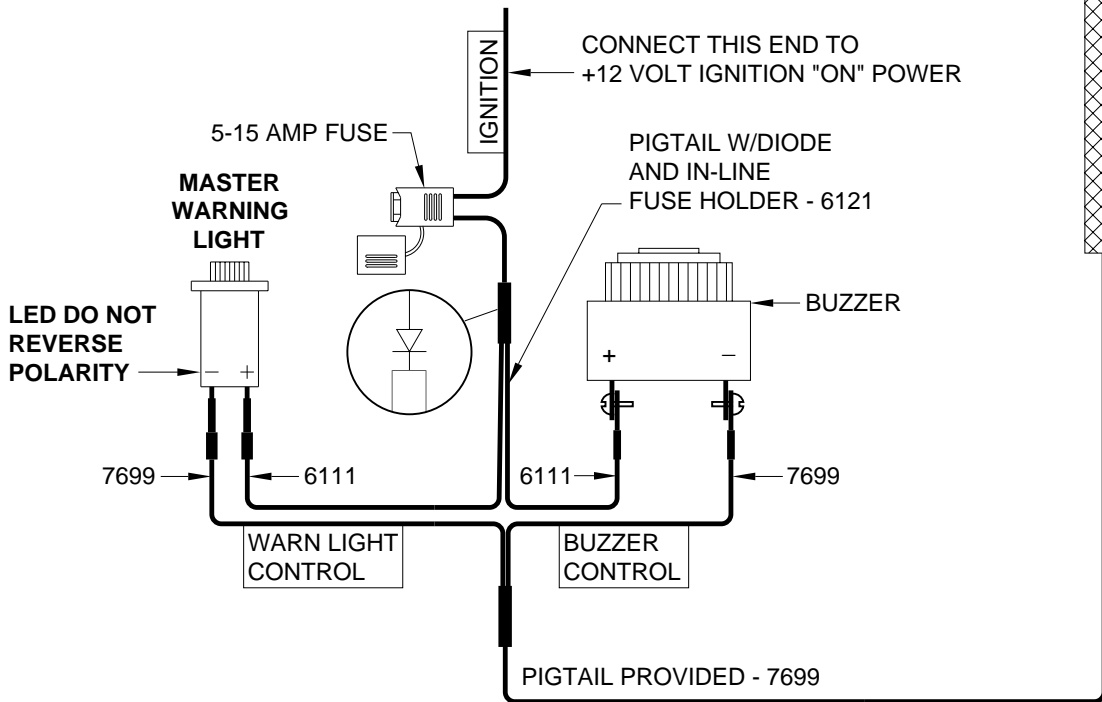

INFORMATION/INSTRUCTION SHEET

HYDRAULIC SOLENOID VALVE

IDENTIFICATION - MANUAL OPERATIONS - REPLACEMENT

REPLACEMENT VALVES WILL HAVE A VALVE RELEASE CAM

BREATHER CAP W/NUT DRIVER

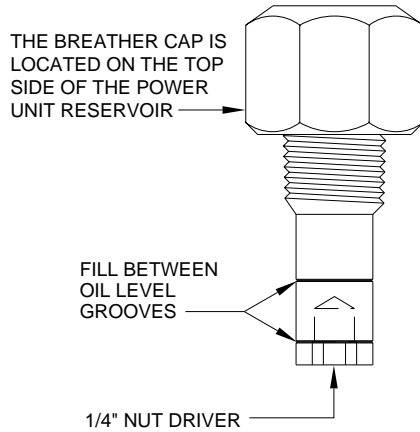

IMPORTANT: PRIOR TO REMOVING THE BREATHER CAP, EITHER TO CHECK THE OIL LEVEL OR TO USE 1/4" NUT DRIVER, CLEAN ANY DEBRIS FROM THE TOP OF THE RESERVOIR. BEFORE RETURNING THE BREATHER CAP TO THE RESERVOIR, REMOVE ANY PAINT CHIPS OR OTHER DEBRIS FROM THE DIPSTICK INCLUDING DEBRIS INSIDE THE 1/4" NUT DRIVER.

SOLENOID VALVES WITH CAM RELEASE

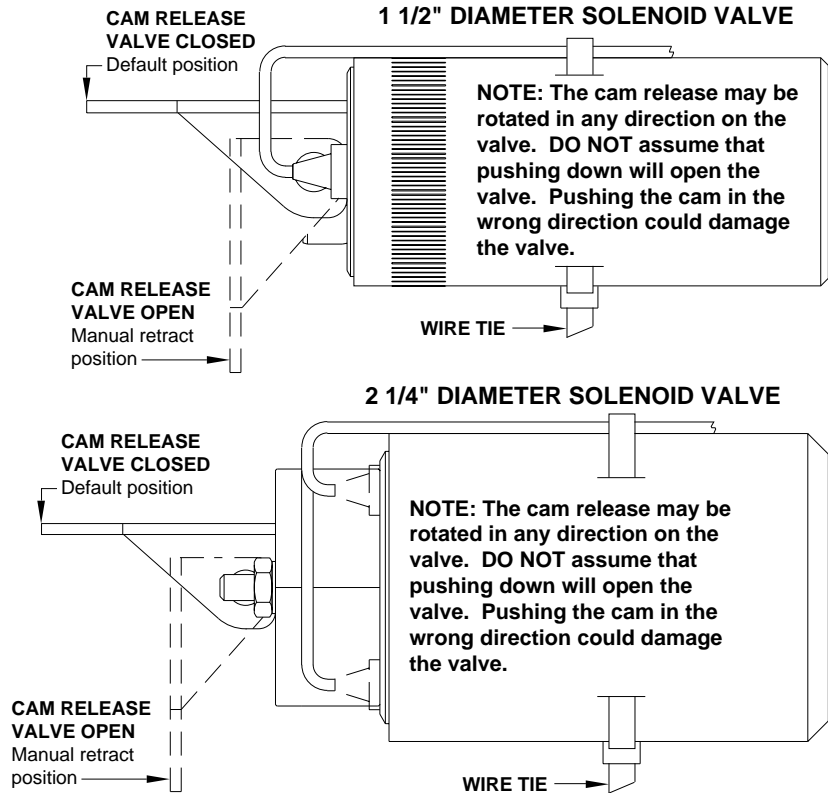

SOLENOID VALVES WITH 1/4" NUT RELEASE

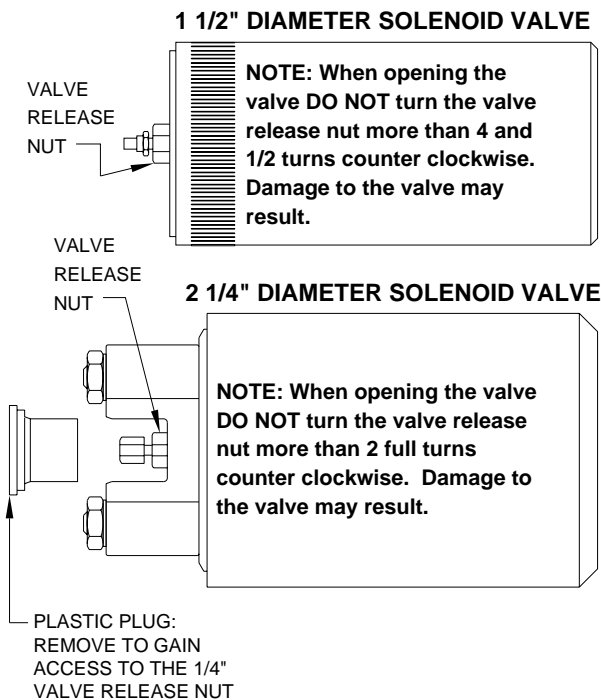

SOLENOID VALVES WITH T-HANDLE RELEASE

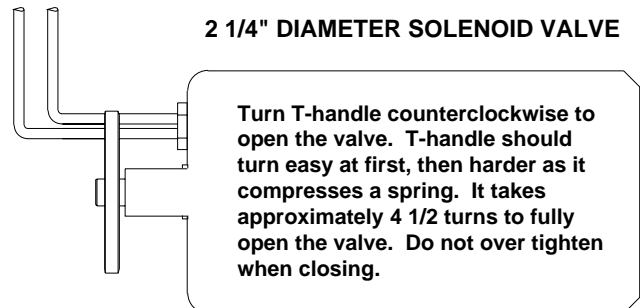

NOTE: OLD STYLE HEX SHAPED SOLENOID VALVES HAVE NO MANUAL VALVE RELEASE.