

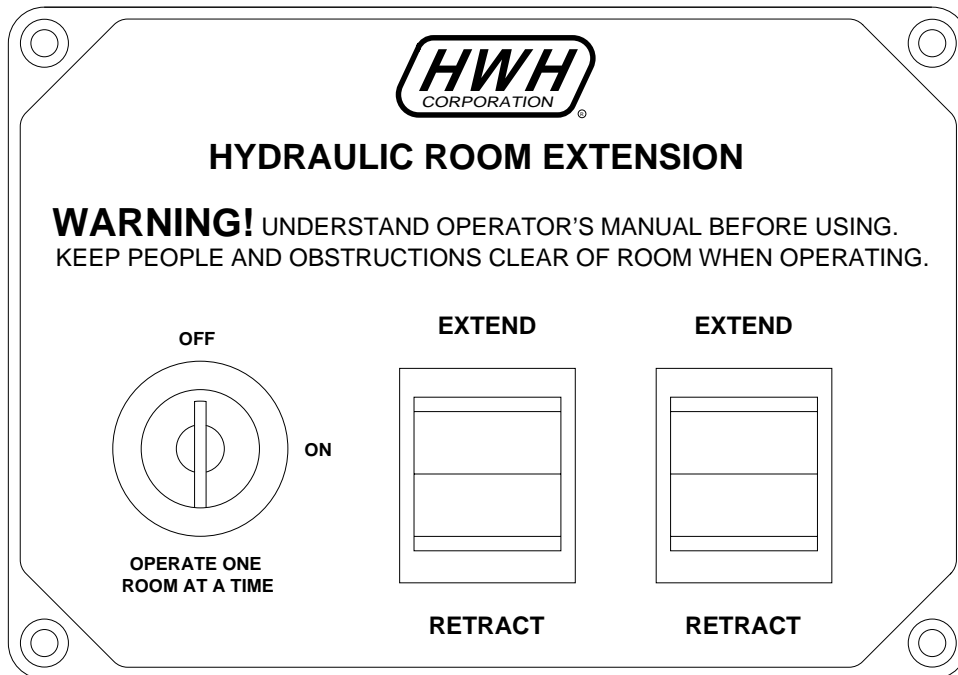

# OPERATOR'S MANUAL

## HWH® HYDRAULIC SPACEMAKER® ROOM EXTENSION SYSTEMS

**FEATURING:**  
*Universal Level Out Room Extensions*



**HWH CORPORATION**  
(On I-80, Exit 267 South)  
2096 Moscow Road | Moscow, Iowa 52760  
Ph: 800/321-3494 (or) 563/724-3396 | Fax: 563/724-3408  
[www.hwh.com](http://www.hwh.com)

---

# OPERATOR'S MANUAL

---

## WARNING !

**READ THE ENTIRE OPERATOR'S MANUAL BEFORE OPERATING.**

**KEEP PEOPLE AND OBSTRUCTIONS CLEAR OF ROOM OR STEP WHEN OPERATING. ANY OBJECT OBSTRUCTING ROOM OR STEP MOVEMENT MAY BE CRUSHED CAUSING INJURY OR DEATH AND VEHICLE DAMAGE.**

**NEVER PLACE HANDS OR OTHER PARTS OF THE BODY NEAR HYDRAULIC LEAKS. OIL MAY PENETRATE SKIN CAUSING INJURY OR DEATH.**

**WEAR SAFETY GLASSES WHEN INSPECTING OR SERVICING THE SYSTEM TO PROTECT EYES FROM DIRT, METAL CHIPS, OIL LEAKS, ETC. FOLLOW ALL OTHER APPLICABLE SHOP SAFETY PRACTICES.**

## HOW TO OBTAIN WARRANTY SERVICE

### THIS IS NOT TO BE INTERPRETED AS A STATEMENT OF WARRANTY

HWH CORPORATION strives to maintain the highest level of customer satisfaction. Therefore, if you discover a defect or problem, please do the following:

**FIRST:** Notify the dealership where you purchased the vehicle or had the leveling system installed. Dealership management people are in the best position to resolve the problem quickly. If the dealer has difficulty solving the problem, he should immediately contact the Customer Service Department, at HWH CORPORATION.

**SECOND:** If your dealer cannot or will not solve the problem, notify the Customer Service Department:  
HWH CORPORATION 2096 Moscow Rd. Moscow IA. 52760  
(563) 724-3396 OR (800) 321-3494. Give your name and address, coach manufacturer and model year, date the coach was purchased, or the date of system installation,

description of the problem, and where you can be reached during business hours (8:00 a.m. till 5:00 p.m. c.s.t.). HWH CORPORATION personnel will contact you to determine whether or not your claim is valid. If it is, HWH CORPORATION will authorize repair or replacement of the defective part, either by appointment at the factory or by the authorization of an independent service facility, to be determined by HWH CORPORATION. All warranty repairs must be performed by an independent service facility authorized by HWH CORPORATION, or at the HWH CORPORATION factory, unless prior written approval has been obtained from proper HWH CORPORATION personnel.

# CONTROL IDENTIFICATION

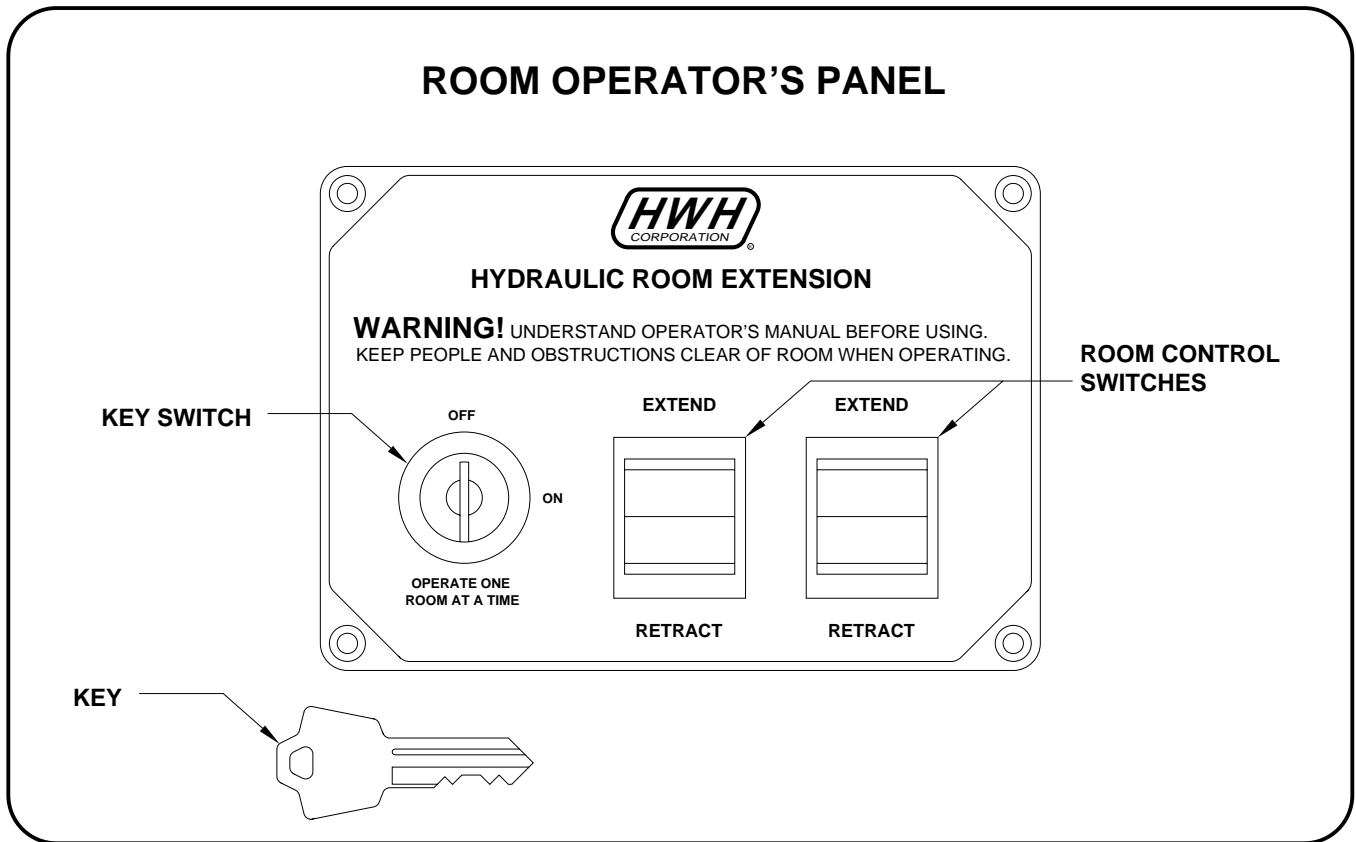

## CONTROL FUNCTIONS

**KEY SWITCH:** The KEY SWITCH controls power to the ROOM CONTROL SWITCH. When the KEY SWITCH is in the "ON" POSITION the room can be operated, and the key cannot be removed. When the KEY SWITCH is in the "OFF" position the room cannot be operated, and the key can be removed.

**ROOM CONTROL SWITCH:** The ROOM CONTROL SWITCH is a two position momentary switch. Pressing the switch in the EXTEND POSITION will extend the room. Pressing the switch in the RETRACT POSITION will retract the room. Releasing the ROOM CONTROL SWITCH will halt the operation of the room.

---

# CONTROL IDENTIFICATION

## PUMP RUN TIME

---

### PUMP RUN TIME

Pump motors used with HWH leveling systems and room extension systems come in 3 different diameters; 3", 3.7" and 4.5". Contact the vehicle manufacturer or HWH for help with identifying the motor size. **It is important that any time the pump runs for more than three minutes with a 3" motor; or six minutes with a 3.7" or 4.5" motor that the motor is allowed to cool for thirty minutes before continuing. Continuous operation of the pump motor without allowing the motor to cool can damage the motor.** For cold weather information see "COLD WEATHER OPERATIONS" below.

The HWH systems with a computer processor monitor the pump run time and will turn the pump off if the run time exceeds a specified time. This time can vary with different systems. Due to available electronics or system design, the pump run time programs will also vary. Leveling systems and room extensions that are not controlled by a system processor have no pump run time protection. **DO NOT run the pump more than three or six minutes without allowing the pump motor to cool for thirty minutes.**

#### SYSTEM VARIATIONS FOR PUMP RUN TIME

Some systems with rooms run the rooms separate from the system processor. These systems do not monitor pump run time when operating the rooms. **DO NOT run the pump more than three or six minutes without allowing the pump motor to cool for thirty minutes.**

Some systems can be turned back on immediately after the processor turns the pump off. **DO NOT turn the system back on or run the pump without allowing the pump motor to cool for thirty minutes.**

When operating some leveling systems manually or operating the room extensions, the pump will turn off and back on while pushing the control button when the pump run time has been exceeded. **DO NOT continue without allowing the pump motor to cool for thirty minutes.**

With some systems, when the processor has turned the pump off because the run time has been exceeded, power to the HWH system must be turned off and back on before the system will operate. With motorized vehicles, turn the ignition off and back on. With non-motorized vehicles, turn the master power switch for the HWH system off and back on. **DO NOT continue without allowing the pump motor to cool for thirty minutes.**

Some HWH systems are equipped with a lighted reset switch. If the processor turns the pump off because the run time has been exceeded, the light in the reset switch will turn on. The system will not operate until the reset switch is pushed.

**DO NOT continue without allowing the pump motor to cool for thirty minutes.**

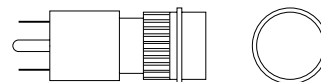

LIGHTED RESET SWITCH

**No matter what HWH system is on the vehicle, the pump should not be ran for more than three minutes (3" motors) or six minutes (3.7" or 4.5" motors) without allowing the pump motor to cool for thirty minutes. Continuous operation of the pump motor without allowing the motor to cool can damage the pump motor.**

Contact HWH corporation to get specific information about the system in this vehicle.

## COLD WEATHER OPERATIONS

HWH leveling and room extension systems are designed to function in cold weather down to 0 degrees Fahrenheit. Below freezing (32 degrees Fahrenheit) the jacks or rooms will operate slower than usual.

For operation in temperatures dropping below -20 degrees Fahrenheit, it is necessary that the system is equipped with oil designed for extreme cold weather application such as a synthetic oil. (Contact HWH for recommendations.)

**DO NOT run the pump motor continuously. It is important that any time the pump runs for more than three minutes with a 3" motor; or six minutes with a 3.7" or 4.5" motor that the motor is allowed to cool for thirty minutes before continuing. Continuous operation of the pump motor without allowing the motor to cool can damage the motor.** Continuous operation of the pump with slow moving jacks or rooms in cold weather, without allowing the pump motor to cool will cause the pump motor to burn up and damage the pump assembly.

---

# OPERATING PROCEDURES

---

## ROOM EXTEND PROCEDURE

**WARNING:** OPERATING A ROOM WITH ANY ROOM LOCKING, CLAMPING OR MANUAL RETRACTING DEVICES ATTACHED OR ENGAGED CAN CAUSE PERSONAL INJURY AND VEHICLE DAMAGE. IT IS THE OPERATOR'S RESPONSIBILITY TO ENSURE THAT ALL ROOM LOCKING, CLAMPING OR MANUAL RETRACTING DEVICES ARE DETACHED OR DISENGAGED BEFORE OPERATING THE ROOM.

Refer to vehicle manufacturer for proper sequence of room extension and leveling system operation.

1. Unlock all room-locking devices to include travel clamps/locks supplied by manufacturers other than HWH.

**NOTE:** If a MANUAL RETRACT WINCH is attached to the room remove it before extending the room.

**WARNING:** KEEP PEOPLE AND OBSTRUCTIONS CLEAR OF ROOM WHEN OPERATING.

**NOTE:** Make sure there is adequate clearance to fully extend the room.

2. Turn the room control panel KEY SWITCH to the "ON" position.

**NOTE:** The park brake must be set to operate the rooms.

3. To extend the room, press and hold the ROOM CONTROL SWITCH in the "EXTEND" position until the room is fully extended.

**IMPORTANT:** If the room extension is a level out room, hold the room control switch to the extend position until the room is fully extended and has dropped to the completely lowered position.

**NOTE:** Hold the switch to "EXTEND" three or four seconds after the room is fully extended. This assures proper pressurization of the cylinders. **During normal operation of the room, do not reverse direction of the room until the room is fully extended. If necessary, the direction of the room may be reversed, but watch for binding of the room. If the direction of the room has been reversed, DO NOT re-extend the room until the room has been fully retracted.**

**IMPORTANT:** Do not hold the ROOM CONTROL SWITCH in the "EXTEND" position for more than ten seconds after the room is fully extended (and down if applicable) or stops moving. **If either side of the room stops moving, release the room control switch immediately. DO NOT force the room. DO NOT reverse direction of the room, contact HWH Customer Service for assistance 1-800-321-3494.**

**NOTE:** Releasing the ROOM CONTROL SWITCH will halt the operation of the room.

4. Turn the room control panel KEY SWITCH to the "OFF" position.

**IMPORTANT:** Do not use a room extension support when the vehicle is supported by the leveling system.

If the room cannot be extended with the room control switch, refer to the AUXILIARY HAND PUMP page.

---

# OPERATING PROCEDURES

---

## ROOM RETRACT PROCEDURE

**WARNING: KEEP PEOPLE AND OBSTRUCTIONS CLEAR OF ROOM WHEN OPERATING.**

Refer to vehicle manufacturer for proper sequence of room extension and leveling system operation.

1. The park brake must be set. The room will not operate if the park brake is not set.
2. Turn the room control panel KEY SWITCH to the "ON" position.
3. To retract the room press and hold the ROOM CONTROL SWITCH in the "RETRACT" position until the room is fully retracted.

**Important: if the room extension is a level-out room, the room must raise completely before it will retract. If the room will not raise, do not force the room. Refer to the MANUAL ROOM LIFT PROCEDURES page.**

**NOTE:** Hold the switch to "RETRACT" three or four seconds after the room is fully retracted. This assures proper pressurization of the cylinders. **During normal operation of the room, do not reverse direction of the room until the room is fully retracted. If necessary, the direction of the room may be reversed, but watch for binding of the room. If the direction of the room has been reversed, DO NOT retract the room until the room has been fully extended.**

**IMPORTANT:** Do not hold the ROOM CONTROL SWITCH in the "RETRACT" position for more than ten seconds after the room is fully retracted or stops moving.

**If either side of the room stops moving, release the room control switch immediately. DO NOT force the room. DO NOT reverse direction of the room, contact HWH Customer Service for assistance 1-800-321-3494.**

**NOTE: Releasing the ROOM CONTROL SWITCH will halt the operation of the room.**

4. Turn the room control panel KEY SWITCH to the "OFF" position.
5. If the room will not retract see AUXILIARY HANDPUMP OPERATION - ROOMS ONLY or the MANUAL ROOM RETRACT PROCEDURE.

**IMPORTANT: Room-locking devices should be locked while traveling.**

# OPERATING PROCEDURES

## "UNIVERSAL PLATFORM LEVEL-OUT" ROOM EXTENSION MECHANISM MANUAL ROOM LIFT PROCEDURES

**NOTE: Manual room lift procedures must be done before manual room retraction procedures.**

1. Determine which extend and retract solenoid valves are assigned to the room. Manually open the valve release cams for the extend and retract solenoid valves by moving the cams to the "VALVE OPENED" position as shown.

**IMPORTANT: RELEASE CAM MIGHT BE ROTATED TO ANY DIRECTION ON THE VALVE. MAKE SURE TO MOVE THE RELEASE CAMS IN THE CORRECT DIRECTION. INCORRECT MOVEMENT OF THE CAMS CAN DAMAGE THE VALVES.**

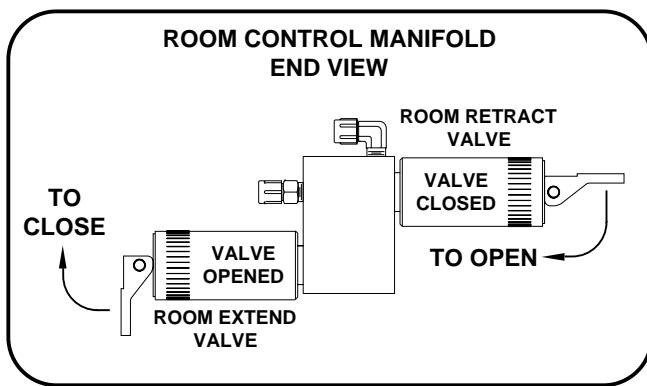

If this manifold is equipped with an auxiliary hand pump, you may be able to retract the room by opening only the room retract valve and operating the hand pump, refer to the AUXILIARY HAND PUMP OPERATION page for instructions on the use of the hand pump and valves equipped with a release cam. If the room cannot be retracted with the hand pump, it will be necessary to use the lift bolts and room retract screws.

**NOTE: There may be more than one platform lift cylinder assembly. There is a manual lift bolt for each assembly. All lift bolts must be used to lift the room.**

Use a 13/16 wrench or socket to rotate the lift bolt(s) clockwise until they are seated in the receiver block. **DO NOT USE AN IMPACT WRENCH TO TURN LIFT BOLTS.** Continue to turn the bolt(s) until the room is completely lifted. When there are multiple lift bolts, alternate evenly between all lift bolts, turning each bolt two or three complete turns each time. **Turning one lift bolt without alternating may cause the room to bind.**

4. Leave the valves opened and refer to the next page for room retract procedures.

**IMPORTANT: If at any stage something is not understood or if the room begins to bind DO NOT force the room, contact HWH Customer Service for assistance 1-800-321-3494.**

**DO NOT RETRACT LIFT BOLT UNTIL YOU HAVE READ "EXTENDING ROOM AFTER SERVICE" ON NEXT PAGE.**

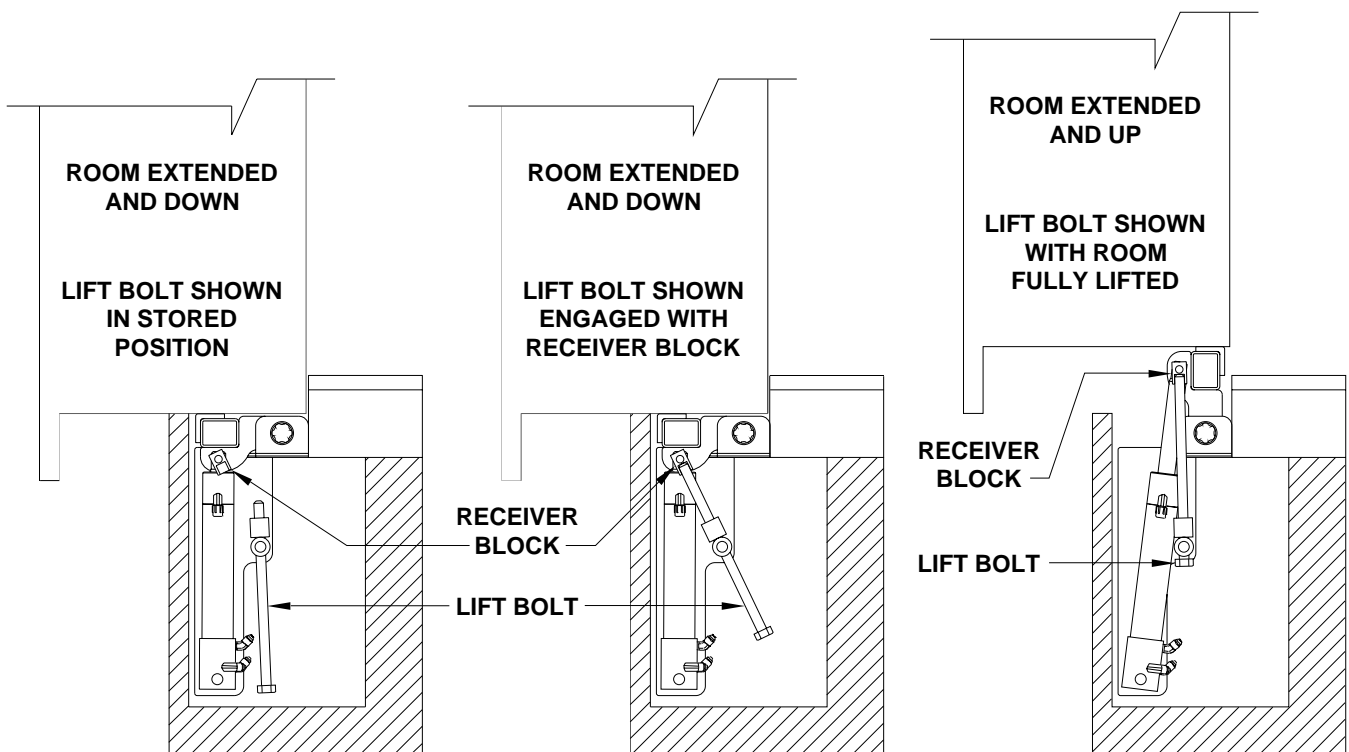

# OPERATING PROCEDURES

## "UNIVERSAL PLATFORM LEVEL-OUT" (UPLO) SLIDE-OUT SYSTEMS

### MANUAL ROOM RETRACT PROCEDURES

**NOTE: Manual room lift procedures must be done before manual room retraction procedures.**

1. Start both threaded rods until resistance is met, one for the front and one for the rear mechanism should be provided.

**NOTE: To access the threaded plates refer to vehicle manufacturer.**

2. **Do Not use an impact wrench.** Using wrench provided, a personal wrench or a tire iron with a 1-1/8" opening rotate either mechanism's threaded rod clockwise 6 complete turns.

3. Move to the other room extension mechanism, rotate the threaded rod clockwise 12 complete turns.

4. Return to the first room extension mechanism and rotate the threaded rod clockwise 12 complete turns. Repeat steps 3 and 4 alternating from mechanism to mechanism rotating each threaded rod 12 complete turns until room is sealed. (DO NOT exceed 15 ft.lbs) Make sure the room does not bind.

**IMPORTANT: If at any stage something is not understood or if the room begins to bind DO NOT force the room, contact HWH Customer Service for assistance 1-800-321-3494.**

**NOTE: Leave the solenoid valves open, the lift bolts and threaded rods in place until the room has been serviced.**

#### EXTENDING ROOM AFTER SERVICE

1. **Room lift bolts should not be retracted yet.** Push and hold the room switch to "RETRACT" for 5 to 10 seconds.

**IMPORTANT: DO NOT EXTEND THE ROOM UNTIL THE ROOM HAS BEEN SERVICED. ANY SOLENOID VALVES LEFT OPEN SHOULD BE CLOSED. THE THREADED RODS SHOULD BE COMPLETELY REMOVED BEFORE ROOM IS FULLY EXTENDED.** If there is not enough room to remove both threaded rods completely, alternate backing the threaded rods out and slightly extending the room. Be careful to not extend the room so far that the threaded rods impact the coach wall or the mechanism.

2. Push the room switch to "EXTEND" until the room is within 1 inch of being fully extended. Threaded rods should be completely removed at this time. **Do not allow room to bind.**

3. Retract all lift bolts completely. If room starts to drop, alternate between lift bolts evenly while turning lift bolts.

4. After lift bolts are retracted, push room switch to "EXTEND" until room is fully extended and down. If room dropped while retracting lift bolts, push room switch to "EXTEND" for 5 to 10 seconds.

5. Retract room with room switch.

**IMPORTANT: If at any stage something is not understood or if the room begins to bind DO NOT force the room, contact HWH Customer Service for assistance 1-800-321-3494.**

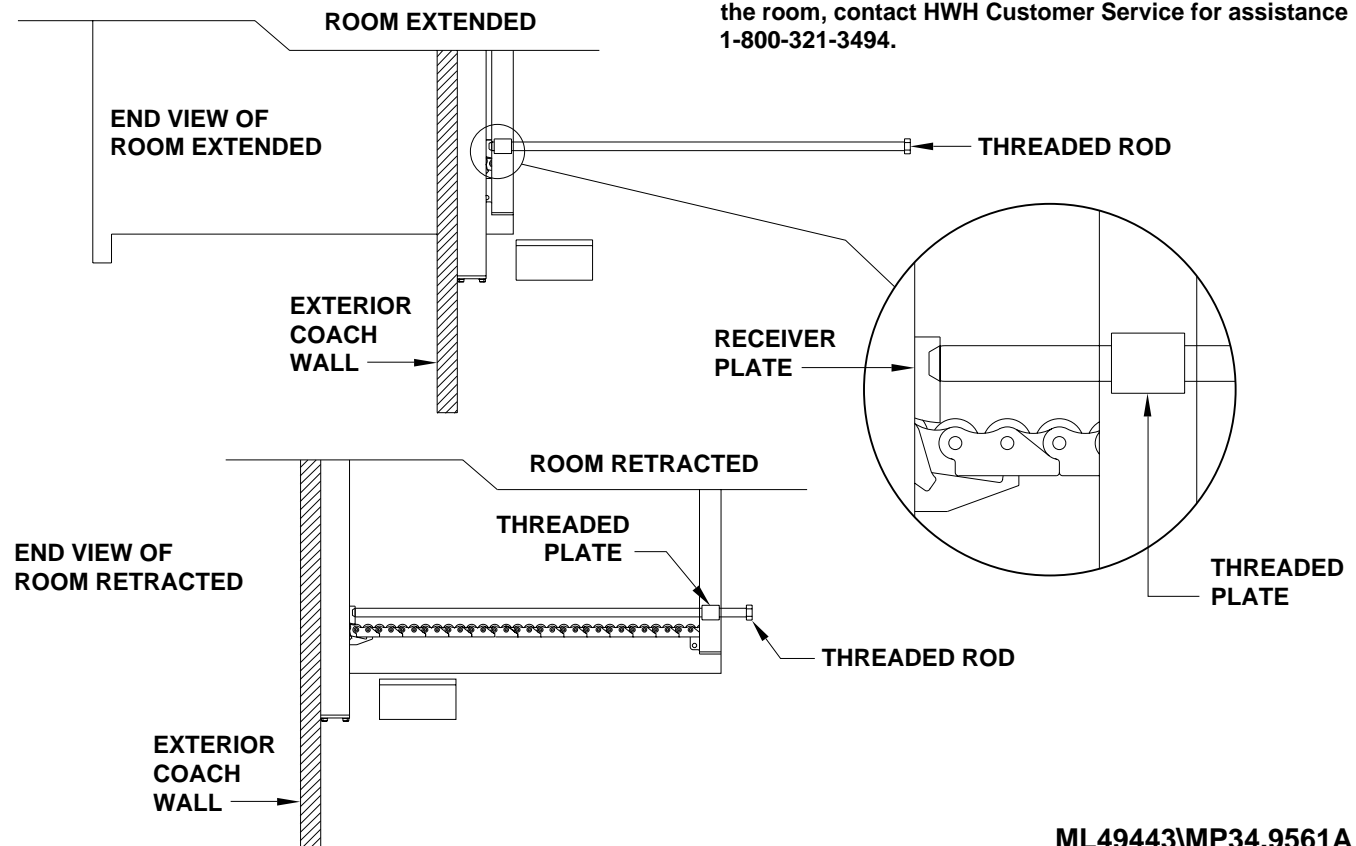



# OPERATING PROCEDURES

## AUXILIARY HAND PUMP OPERATION - ROOMS ONLY

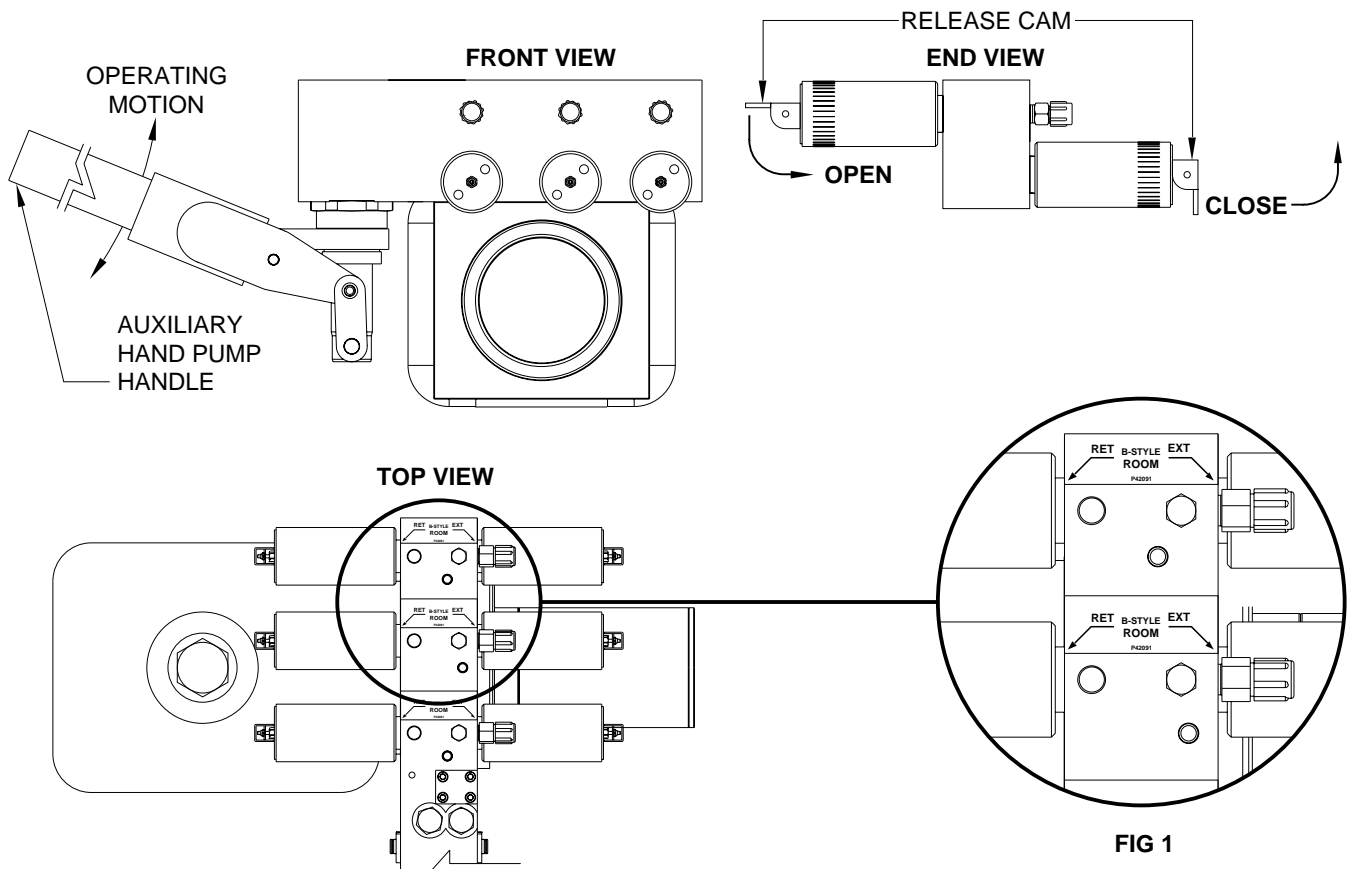

**NOTE:** Each hydraulic function requires a pair of solenoid valves one each for the extend and retract procedures. The number of functions and the items controlled by each pair of solenoid valves will vary for each system. The diagrams shown on this page represent a (3) function system of (3) rooms as indicated by the labels shown in FIG 1. Use the labels specific to your system when following these procedures.

The auxiliary hand pump can be used to extend or retract the room extensions anytime the pump will not function.

The auxiliary hand pump is a two stage pump that will produce enough pressure to extend as well as retract the rooms. When operating the auxiliary pump to extend or retract the rooms, the pump handle will seem to "snap" as the pump goes to the second stage. The pumping action will be easier at first as the second stage starts to create more pressure.

**NOTE:** The hand pump will swivel to any position which will ease the operation of the hand pump.

To operate the auxiliary hand pump, open the appropriate solenoid valve. Insert the hand pump handle into the handle receptacle and move the handle in an up and down motion.

**NOTE:** If a room cannot be retracted using the auxiliary hand pump, see "MANUAL ROOM RETRACTION PROCEDURES".

**IMPORTANT:** If at any stage something is not understood or if the room begins to bind DO NOT force the room, contact HWH Customer Service for assistance 1-800-321-3494.

The auxiliary hand pump may work easier if only one valve is open at a time.

The room extend and room retract valves may be different for your mechanism(s). Always refer to the stickers on the top of the manifold assembly.

It is recommended to operate the auxiliary hand pump occasionally to check its operation.

**IMPORTANT: ONLY MOVE THE RELEASE CAM IN THE DIRECTION SHOWN. MOVING THE CAM IN THE OPPOSITE DIRECTION CAN DAMAGE THE VALVES.**

---

# MAINTENANCE

---

## PRIMING THE HAND PUMP

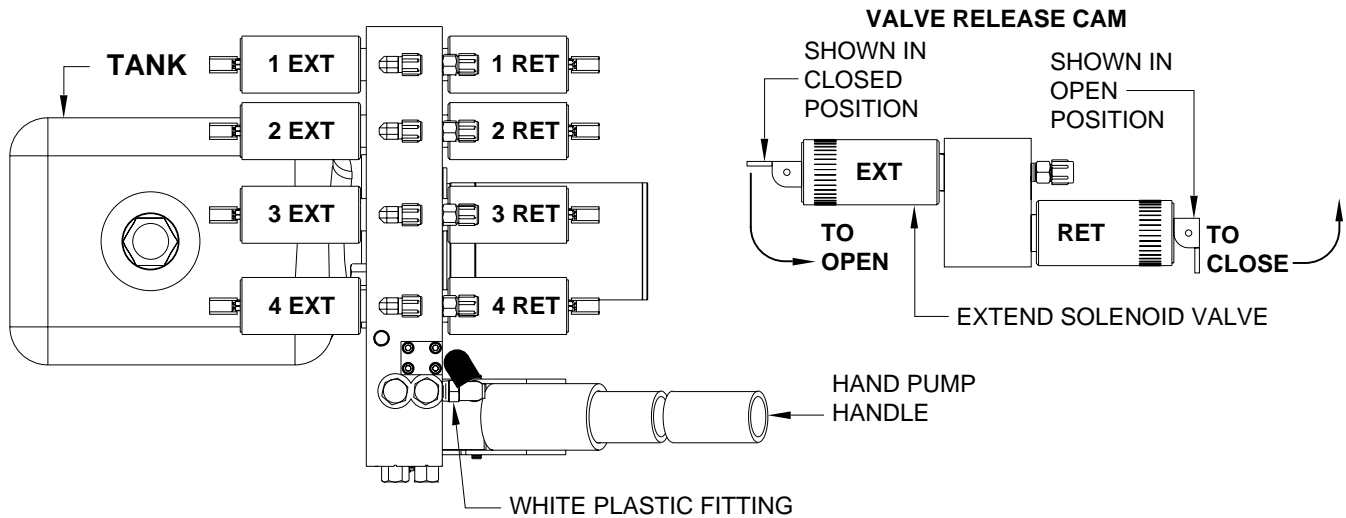

1. To prime the hand pump, open one extend and one retract valve using the valve release cams
2. Make sure the valves opened are for the same function, such as 1 EXT and 1 RET.
3. Make sure the tank is full. Although there should be no loss of fluid, make sure the fluid level does not drop more than 1 inch.
4. Pump the hand pump 8 to 10 times. You may be able to see the fluid, flow through the white plastic fitting.
5. Close both valves. Then try to extend or retract the desired room according to the "AUXILIARY HAND PUMP OPERATION" page.
6. Repeat as necessary until the hand pump will function properly.

---

# MAINTENANCE

---

## OIL LEVEL

All maintenance should be done as part of the normal servicing of the coach.

The oil level should be checked when the vehicle is first purchased and then once every two years. More often if there is an oil leak in the system.

Any HWH room extension cylinders should be completely retracted before checking the oil level. Check applicable hydraulic diagrams for correct position of the room to check the oil level. The oil reservoir is part of the pump / manifold assembly. The oil level is checked and filled through the breather cap. Clear any dirt away from the breather / filler cap before removing. The oil level should be within one inch of the top of the reservoir. Most breather caps have a dipstick.

**NOTE: Overfilling the tank can cause leakage of oil through the breather cap.**

**FLUID:** HWH Specialty Hydraulic Oil is recommended. In an emergency Dexron automatic transmission fluid can be used. **NOTE:** Dexron automatic transmission fluid contains red dye and can cause staining should a leak occur. **DO NOT USE** brake fluid or hydraulic jack fluid. Use of these can damage seals.

## ELECTRICAL SYSTEM

The batteries should be in good condition and fully charged. Weak batteries can cause erratic operation. Battery cable terminals and battery posts and connections should be kept clean.

All electrical connections, especially ground connections, should be clean, tight, free from corrosion and protected from weathering.

## ROOM EXTENSIONS

The HWH room mechanisms need no maintenance. **DO NOT** grease or lubricate any parts of the HWH mechanism.

Any visible mechanism can be kept clean by washing with water. Refer to the vehicle manufacturer for correct maintenance of the room seals.

## VISUAL INSPECTION

Periodically inspect the system for oil leaks and damaged or missing parts, such as rollers or pins. Check the hydraulic lines and wiring for damage and wear.

The system will operate better if kept clean.

## OPERATIONAL CHECK

Review the OPERATOR MANUAL. Run the system according to the SYSTEM OPERATION Section. Note any abnormal operation.

Review the Auxiliary Hand Pump Section. Make sure the hand pump is working properly.

## WINTER WEATHER DRIVING

Anti-icing / deicing agents when splashed on your vehicle, continue to absorb moisture from the air even after they have dried. This can facilitate corrosion of metallic components, such as HWH jacks.

To help reduce the corrosion of jacks after exposure to anti-icing / deicing agents, thoroughly wash jacks with warm soapy water.

# HYDRAULIC LINE CONNECTION DIAGRAM UNIVERSAL LEVEL OUT ROOMS

ROOM 1  
EXTEND ROOM TO CHECK OIL LEVEL

CAP END  
CONNECTION - C

SEE HYDRAULIC LINE  
CONNECTION DIAGRAM  
UNIVERSAL LEVEL OUT  
ROOM EXTENSION

ROD END  
CONNECTION - A

NOTE: ROOMS MAY BE IN DIFFERENT  
LOCATIONS ON THE VEHICLE.

**VALVE FUNCTION**

1E - ROOM 1 CYLINDER  
EXTEND - ROOM RETRACT

1R - ROOM 1 CYLINDER  
RETRACT - ROOM EXTEND

2E - ROOM 2 CYLINDER  
EXTEND - ROOM RETRACT

2R - ROOM 2 CYLINDER  
RETRACT - ROOM EXTEND

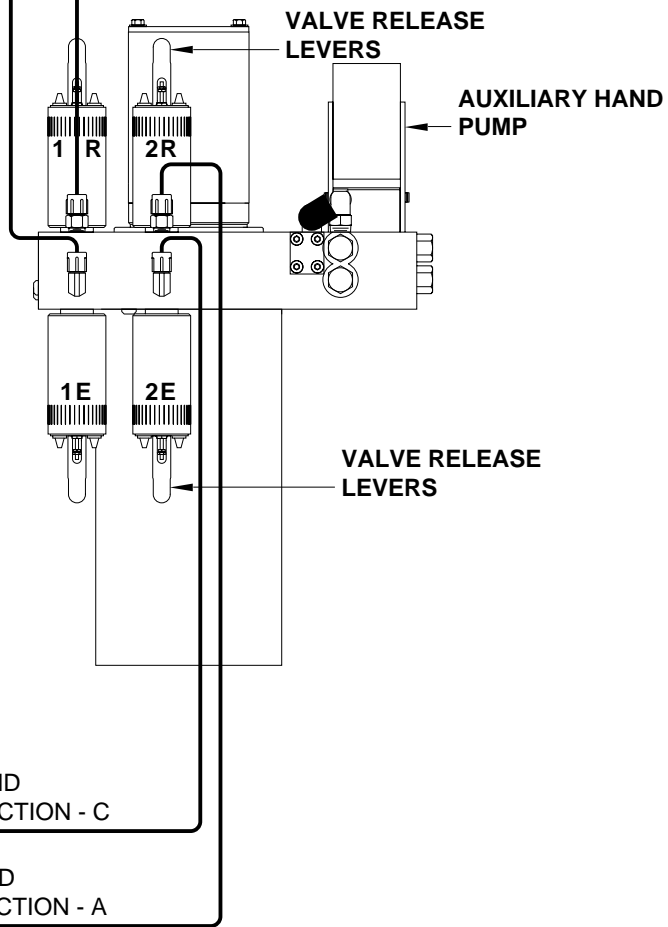

SEE HYDRAULIC LINE  
CONNECTION DIAGRAM  
UNIVERSAL LEVEL OUT  
ROOM EXTENSION

ROD END  
CONNECTION - C

CAP END  
CONNECTION - A

ROOM 2  
EXTEND ROOM TO CHECK OIL LEVEL

# HYDRAULIC LINE CONNECTION DIAGRAM

## UNIVERSAL PLATFORM LEVEL OUT ROOM EXTENSION

FRONT VIEW  
OF MECHANISM

FOR CONNECTION CLARITY,  
ONLY THE ROOM CYLINDERS ARE SHOWN

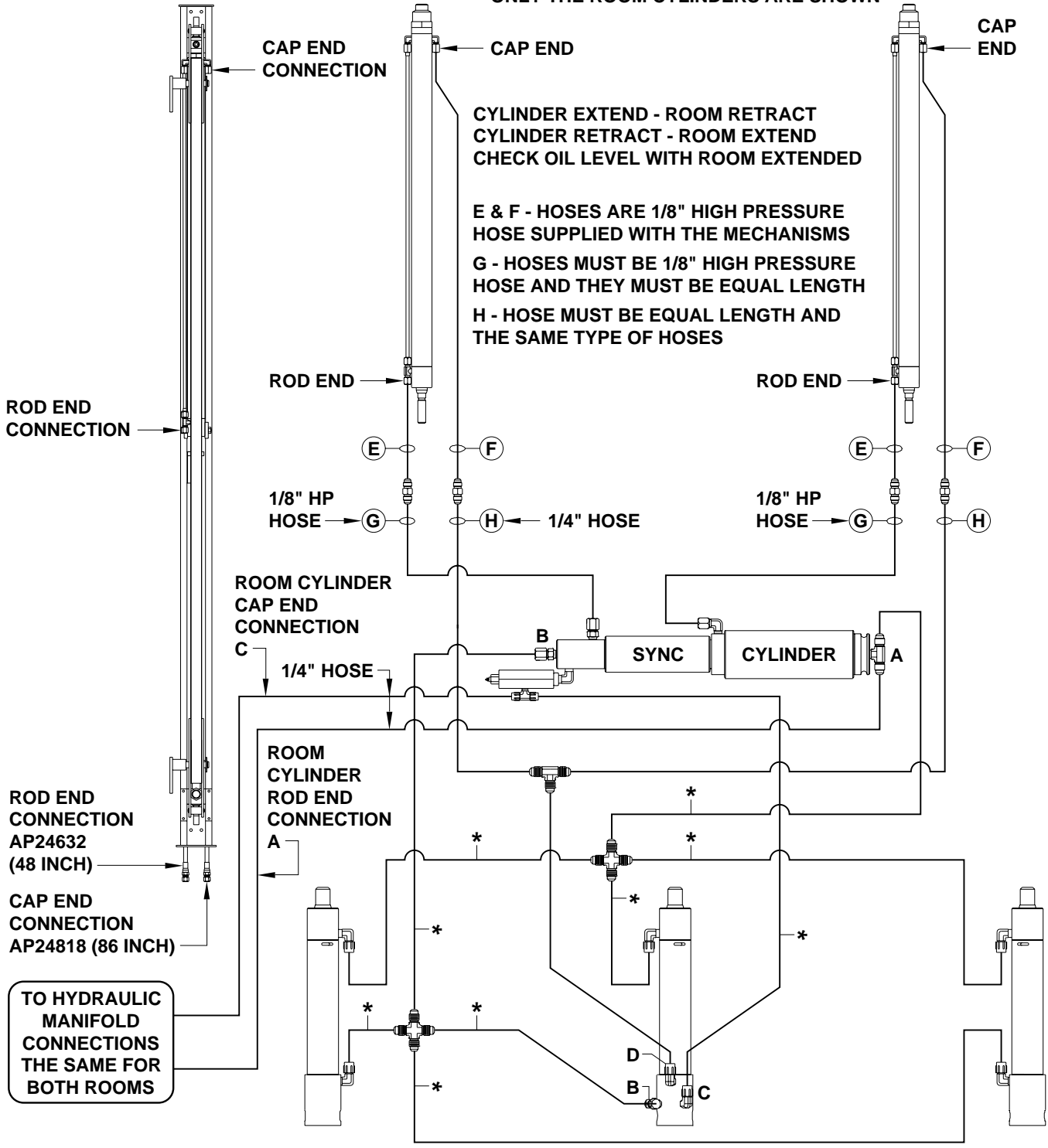

\* = 1/4" HOSE

ROOM LIFT CYLINDERS (3)

CYLINDER EXTEND - ROOM RETRACT  
CYLINDER RETRACT - ROOM EXTEND  
CHECK OIL LEVEL WITH ROOM EXTENDED

E & F - HOSES ARE 1/8" HIGH PRESSURE  
HOSE SUPPLIED WITH THE MECHANISMS  
G - HOSES MUST BE 1/8" HIGH PRESSURE  
HOSE AND THEY MUST BE EQUAL LENGTH  
H - HOSE MUST BE EQUAL LENGTH AND  
THE SAME TYPE OF HOSES

ROD END CONNECTION  
AP24632  
(48 INCH)  
CAP END CONNECTION  
AP24818 (86 INCH)

TO HYDRAULIC  
MANIFOLD  
CONNECTIONS  
THE SAME FOR  
BOTH ROOMS

# ELECTRICAL CONNECTION DIAGRAM

## ROOM EXTENSION MANIFOLD CONNECTIONS

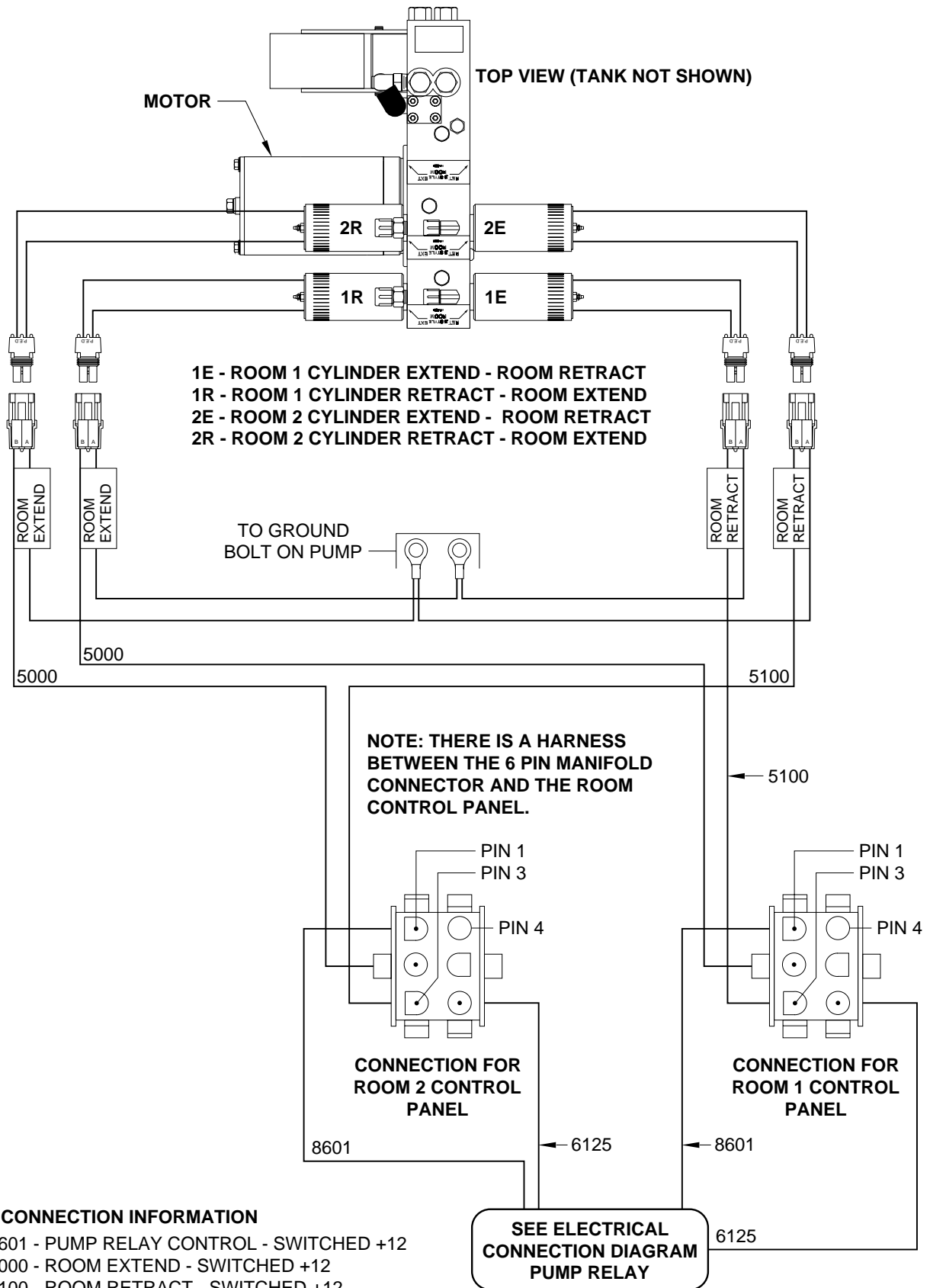

**CONNECTION INFORMATION**

- PIN 1 - 8601 - PUMP RELAY CONTROL - SWITCHED +12
- PIN 2 - 5000 - ROOM EXTEND - SWITCHED +12
- PIN 3 - 5100 - ROOM RETRACT - SWITCHED +12
- PIN 4 AND 5 - NO CONNECTION
- PIN 6 - 6125 - +12 BATTERY
- (PIN INFO SAME FOR ALL BOTH CONNECTORS)

# ELECTRICAL CONNECTION DIAGRAM

## MULTIPLE ROOM EXTENSIONS

### PUMP RELAY

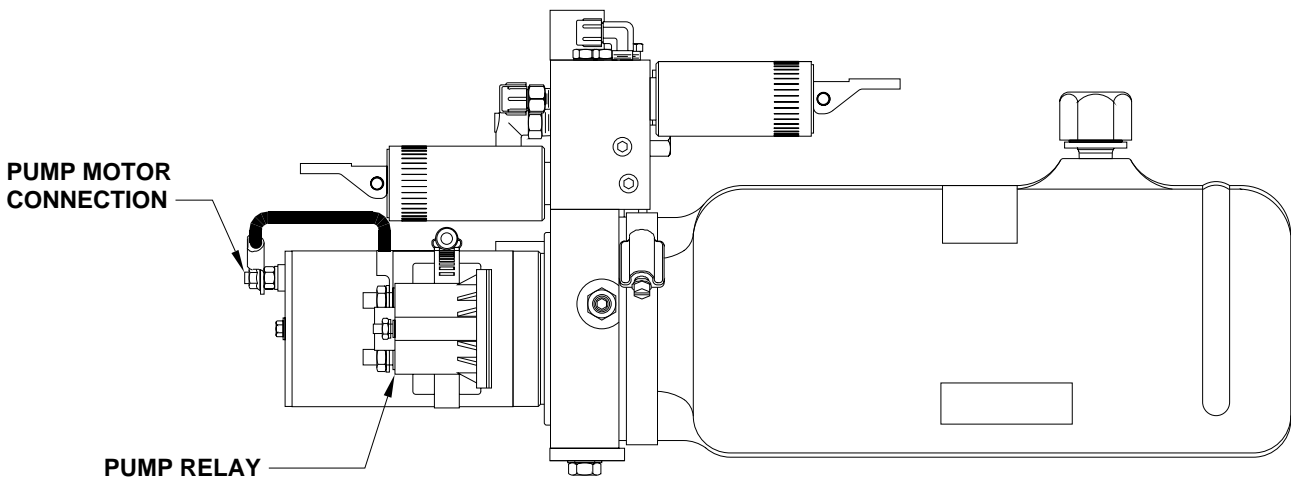
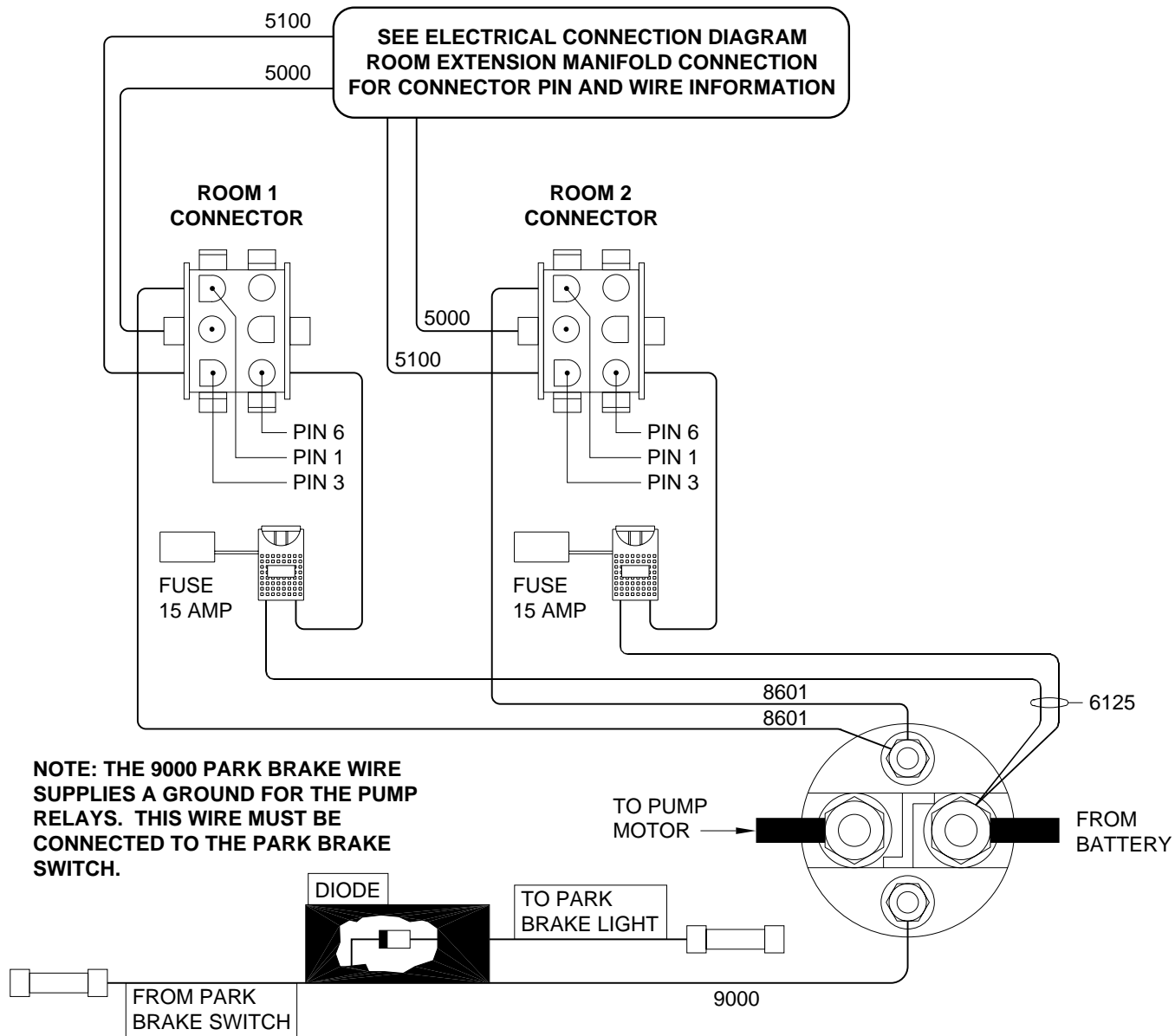

# ELECTRICAL CONNECTION DIAGRAM

## ROOM CONTROL PANEL

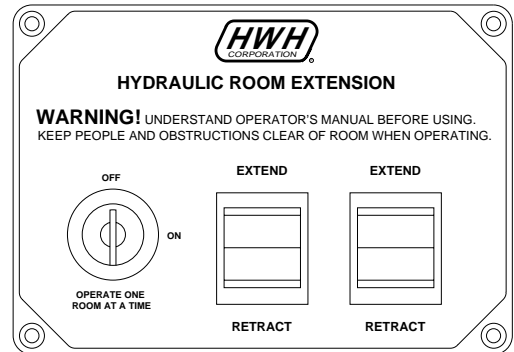
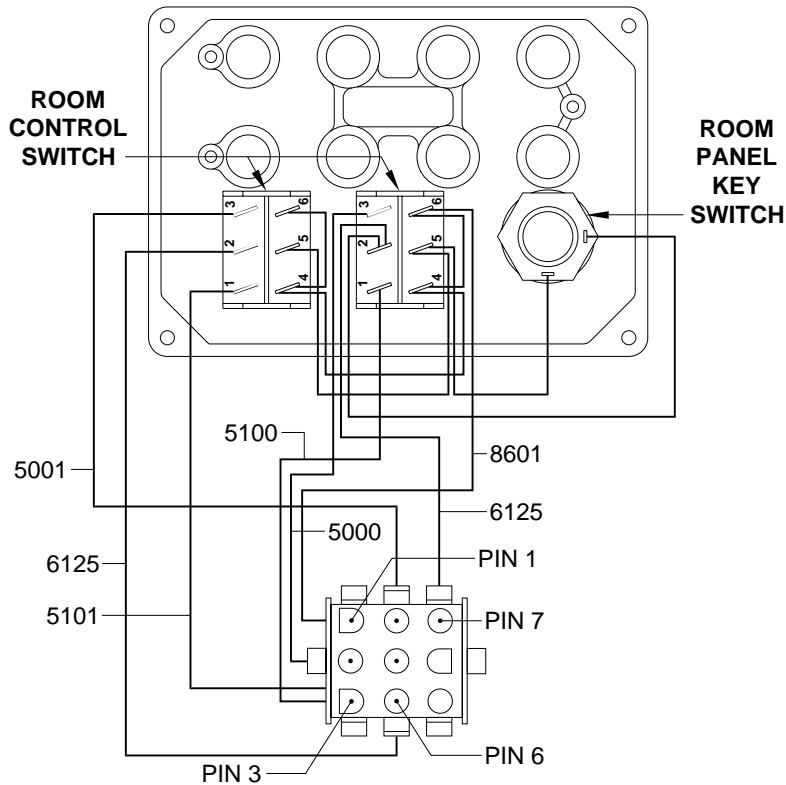

### CONNECTION INFORMATION

- PIN 1 - 8601 - PUMP RELAY CONTROL - SWITCHED +12
- PIN 2 - 5000 - ROOM EXTEND - SWITCHED +12
- PIN 3 - 5100 - ROOM RETRACT - SWITCHED +12
- PIN 4 - 5001 - ROOM 2 EXTEND - SWITCHED +12
- PIN 5 - 5101 - ROOM 2 RETRACT - SWITCHED +12
- PIN 6 - 6125 - +12 BATTERY
- PIN 7 - 6125 - +12 BATTERY
- PIN 8 AND 9 - NO CONNECTION

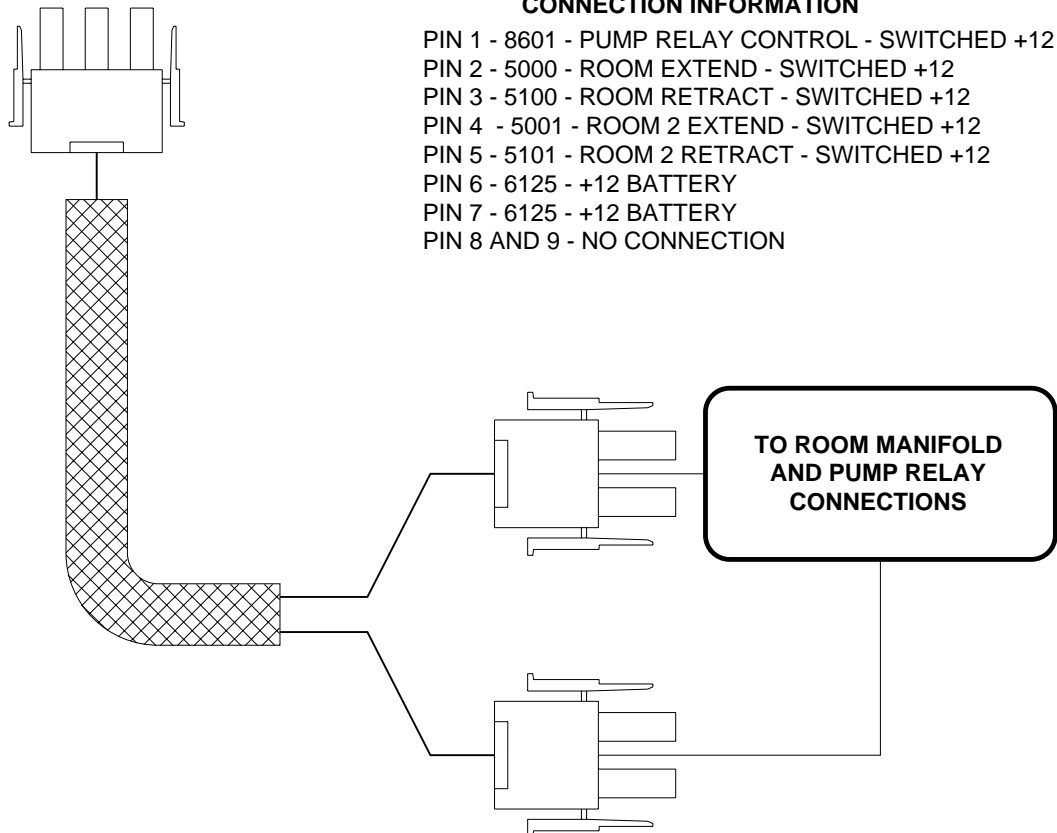



# INFORMATION/INSTRUCTION SHEET

## HYDRAULIC SOLENOID VALVE

### IDENTIFICATION - MANUAL OPERATIONS - REPLACEMENT

**REPLACEMENT VALVES WILL HAVE A VALVE RELEASE CAM**

#### BREATHER CAP W/NUT DRIVER

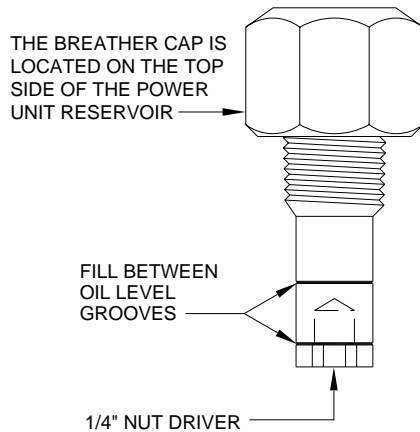

**IMPORTANT: PRIOR TO REMOVING THE BREATHER CAP, EITHER TO CHECK THE OIL LEVEL OR TO USE 1/4" NUT DRIVER, CLEAN ANY DEBRIS FROM THE TOP OF THE RESERVOIR. BEFORE RETURNING THE BREATHER CAP TO THE RESERVOIR, REMOVE ANY PAINT CHIPS OR OTHER DEBRIS FROM THE DIPSTICK INCLUDING DEBRIS INSIDE THE 1/4" NUT DRIVER.**

#### SOLENOID VALVES WITH CAM RELEASE

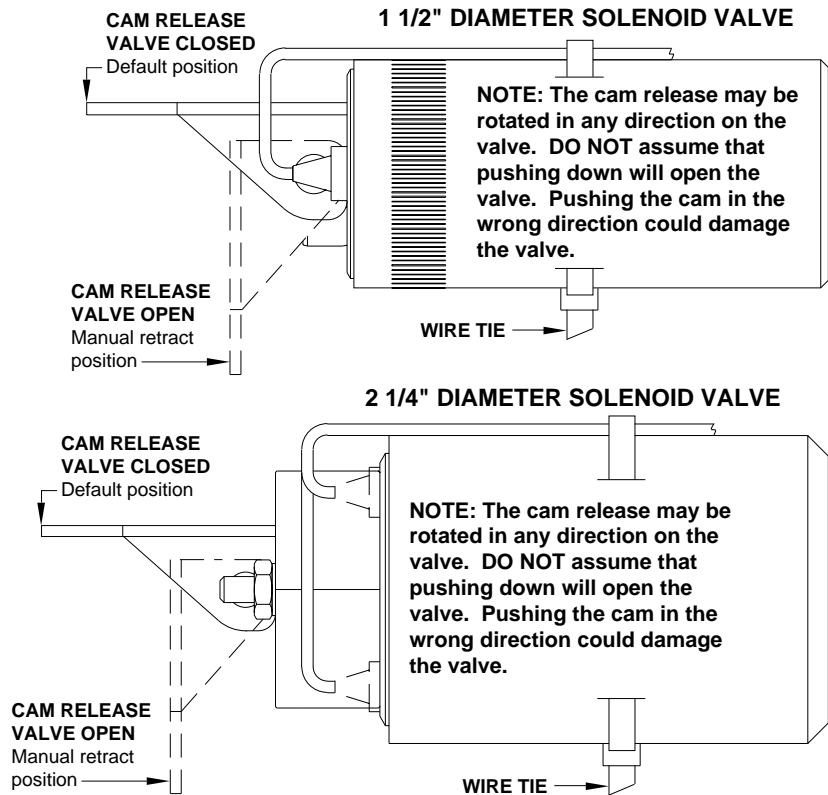

#### SOLENOID VALVES WITH 1/4" NUT RELEASE

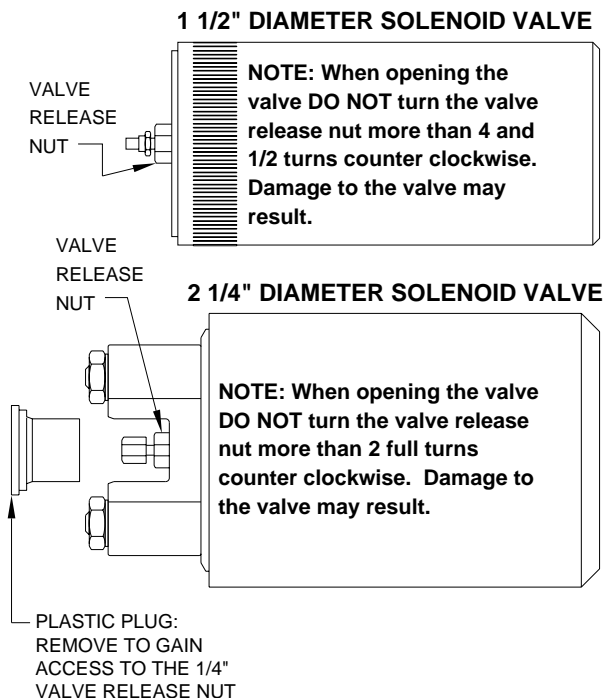

#### SOLENOID VALVES WITH T-HANDLE RELEASE

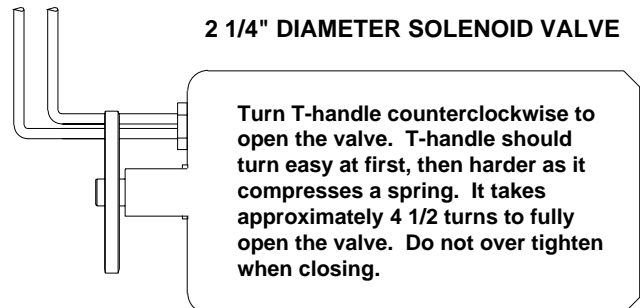

**NOTE: OLD STYLE HEX SHAPED SOLENOID VALVES HAVE NO MANUAL VALVE RELEASE.**