

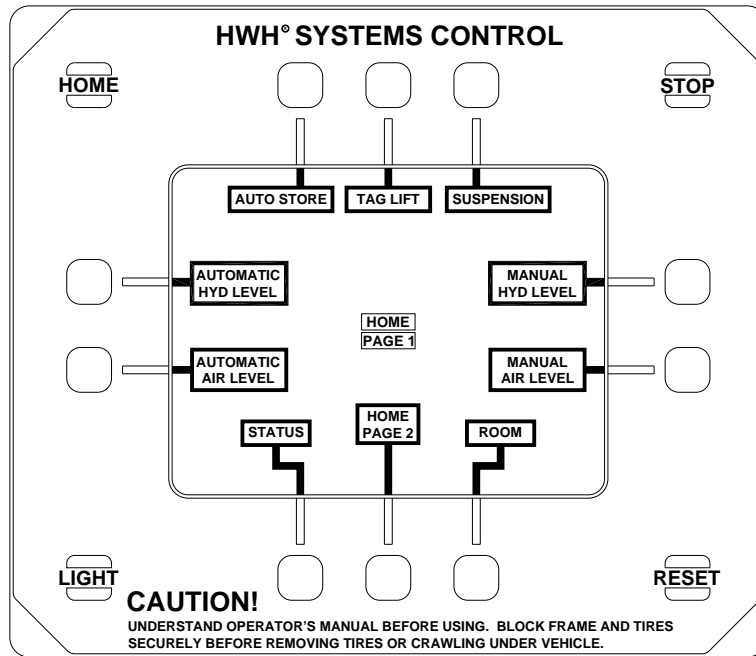

# OPERATOR'S MANUAL

## HWH® SYSTEMS CONTROL MODULE AND SPACEMAKER® ROOM EXTENSION SYSTEMS

**FEATURING:**  
*Active Air Suspension*  
*Computerized Air Leveling*  
*Multiple Room Extensions (with Air Seals)*



**HWH CORPORATION**  
(On I-80, Exit 267 South)  
2096 Moscow Road | Moscow, Iowa 52760  
Ph: 800/321-3494 (or) 563/724-3396 | Fax: 563/724-3408  
[www.hwh.com](http://www.hwh.com)

---

# OPERATOR'S MANUAL

---

## WARNING !

READ THE ENTIRE OPERATOR'S MANUAL BEFORE OPERATING.

BLOCK FRAME AND TIRES SECURELY BEFORE CRAWLING UNDER VEHICLE. DO NOT USE LEVELING JACKS OR AIR SUSPENSION TO SUPPORT VEHICLE WHILE UNDER VEHICLE OR CHANGING TIRES. VEHICLE MAY DROP AND/OR MOVE FORWARD OR BACKWARD WITHOUT WARNING CAUSING INJURY OR DEATH.

KEEP ALL PEOPLE CLEAR OF VEHICLE WHILE LEVELING SYSTEM AND ROOM EXTENSION ARE BEING OPERATED.

NEVER PLACE HANDS OR OTHER PARTS OF THE BODY NEAR HYDRAULIC LEAKS. OIL MAY PENETRATE SKIN CAUSING INJURY OR DEATH.

DO NOT TRAVEL IF THE VEHICLE IS NOT AT THE PROPER RIDE HEIGHT. CONTACT MANUFACTURER TECHNICAL SERVICE FOR TRAVELING WHEN NOT AT THE PROPER RIDE HEIGHT.

DO NOT USE THE DUMP OR RAISE BUTTONS IF THE VEHICLE IS MOVING IN EXCESS OF 5 MPH.

WEAR SAFETY GLASSES WHEN INSPECTING OR SERVICING THE SYSTEM TO PROTECT EYES FROM DIRT, METAL CHIPS, OIL LEAKS, ETC. FOLLOW ALL OTHER APPLICABLE SHOP SAFETY PRACTICES.

IMPORTANT: IF COACH IS EQUIPPED WITH A ROOM EXTENSION, READ ROOM EXTENSION SECTION BEFORE OPERATING LEVELING SYSTEM.

## HOW TO OBTAIN WARRANTY SERVICE

### THIS IS NOT TO BE INTERPRETED AS A STATEMENT OF WARRANTY

HWH CORPORATION strives to maintain the highest level of customer satisfaction. Therefore, if you discover a defect or problem, please do the following:

**FIRST:** Notify the dealership where you purchased the vehicle or had the leveling system installed. Dealership management people are in the best position to resolve the problem quickly. If the dealer has difficulty solving the problem, he should immediately contact the Customer Service Department, at HWH CORPORATION.

**SECOND:** If your dealer cannot or will not solve the problem, notify the Customer Service Department:  
HWH CORPORATION 2096 Moscow Rd. Moscow IA. 52760  
(563) 724-3396 OR (800) 321-3494. Give your name and address, coach manufacturer and model year, date the coach was purchased, or the date of system installation,

description of the problem, and where you can be reached during business hours (8:00 a.m. till 5:00 p.m. c.s.t.). HWH CORPORATION personnel will contact you to determine whether or not your claim is valid. If it is, HWH CORPORATION will authorize repair or replacement of the defective part, either by appointment at the factory or by the authorization of an independent service facility, to be determined by HWH CORPORATION. All warranty repairs must be performed by an independent service facility authorized by HWH CORPORATION, or at the HWH CORPORATION factory, unless prior written approval has been obtained from proper HWH CORPORATION personnel.

# CONTROL IDENTIFICATION

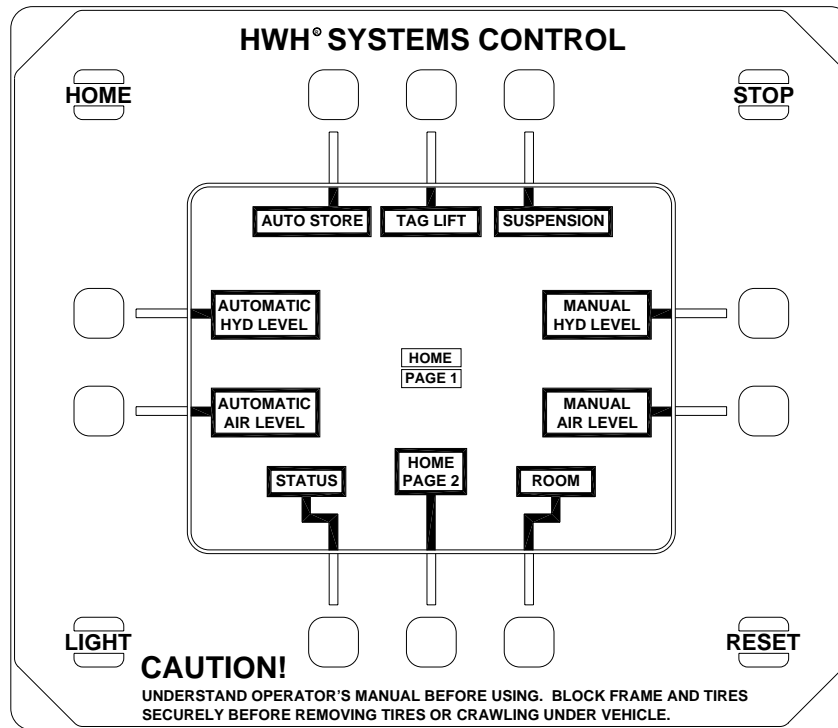

## HOME PAGE

**NOTE:** See individual function pages in the OPERATING PROCEDURES section of this manual for detailed information about specific screen buttons.

## PANEL BUTTONS

**"HOME" BUTTON:** Pushing the "HOME" button at any time will return the control panel to HOME PAGE 1 EXCEPT when the system is actively leveling the vehicle in an automatic mode.

**"LIGHT" BUTTON:** Pushing the "LIGHT" button will turn the back light off. The panel will appear dark but the system will remain on. Push the "LIGHT" button to turn the back light on.

**"STOP" BUTTON:** Pushing the "STOP" button will turn the system off halting any active function including ACTIVE AIR SUSPENSION. If the ignition is on, the Master Warning Light will come on. **IT IS NOT RECOMMENDED TO PUSH THE "STOP" BUTTON WHEN TRAVELING.**

**"RESET" BUTTON:** This button will reset the SYSTEM CONTROL PANEL if the panel ceases to function due to a malfunction. The "RESET" button will also reactivate the CONTROL PANEL if the "STOP" button is pushed at ANY time. The ignition key must be on for the "RESET" button to work.

## SCREEN BUTTONS AND LIGHTS

**"AUTOMATIC HYD LEVEL" BUTTON:** This button will start the automatic hydraulic leveling procedure and bring up the AUTOMATIC HYD LEVEL screen.

**"AUTOMATIC AIR LEVEL" BUTTON:** This button will start the automatic air leveling procedure and bring up the AUTOMATIC AIR LEVEL screen.

**"MANUAL HYD LEVEL" BUTTON:** This button will put the system in the manual hydraulic leveling mode and bring up the HYD LEVEL page for manual hydraulic leveling control.

**"MANUAL AIR LEVEL" BUTTON:** This button will put the system in the manual air leveling mode and bring up the AIR LEVEL page for manual air leveling control.

**"AUTO STORE" BUTTON:** This button will retract the jacks when manual or automatic hydraulic leveling has been used. It also puts the system in the Travel Mode. If Manual or Automatic Air Leveling was used, this button will put the system in the Travel Mode. No matter what type of leveling was done, when the "AUTO STORE" button is pushed the first thing that happens is air is pumped into all the suspension air bags for 10 seconds before the jacks are retracted and/or the system returns to the Travel Mode.

# CONTROL IDENTIFICATION

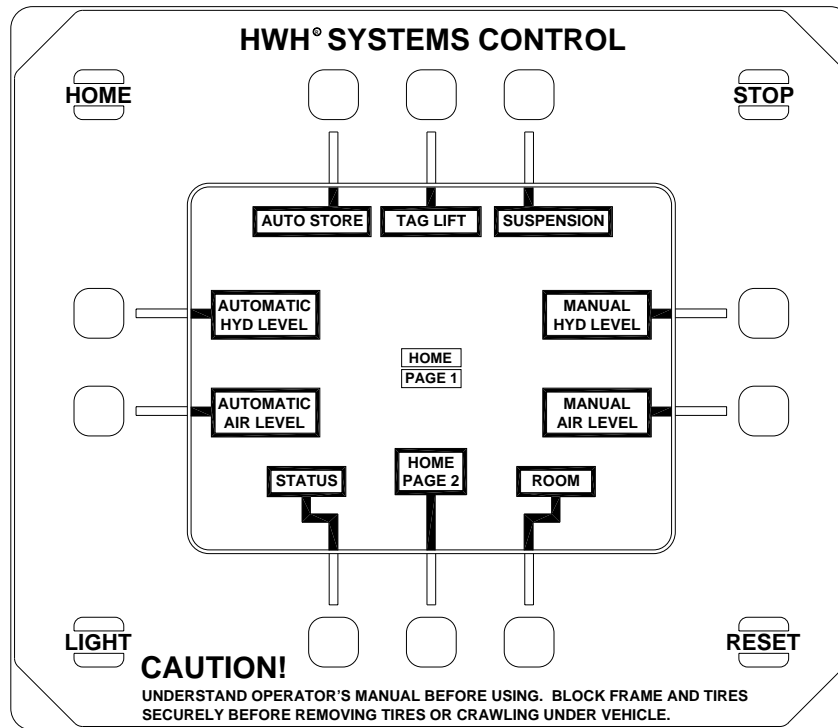

## HOME PAGE CONTINUED

### SCREEN BUTTONS AND LIGHTS CONTINUED

**"AUTO STORE" LIGHT:** This light will flash as "STORING" when the "AUTO STORE" button is pushed. If Hydraulic Leveling was used, this light will flash while the jacks are retracting plus 1 minute after all the jack down indicators are off. If Air Leveling was used, this light will flash for approximately 80 seconds.

**"SUSPENSION" BUTTON:** This button will bring up the Suspension Control page.

**"SUSPENSION" LIGHT:** This light will flash as "SUSPENSION INITIALIZING" until the suspension reaches ride height if the "AUTO STORE" button is pushed and the ignition key is on. If no Leveling System has been used, the "SUSPENSION INITIALIZING" light will flash until the suspension reaches ride height when the ignition key is turned on. Any time the "SUSPENSION INITIALIZING" light is flashing, the Master Warning Light should be on.

**"TAG LIFT" BUTTON:** This button will lift the tag axle. See the "TAG LIFT" section in "OPERATING PROCEDURES".

**"TAG LIFT" LIGHT:** When the letters are black and the background is white, the tag lift is off. The tag axle should be in the Travel Position. When the letters are white and the background is black, the tag lift feature is on. The tag axle should be in the Lift Position.

**"STATUS" BUTTON:** This button will bring up the first "STATUS" page. There will be multiple "STATUS" pages. The "PAGE DOWN" button on a "STATUS" page will advance the screen to the next "STATUS" page. The "STATUS" pages show the status or position of different systems and equipment. This includes items such as ACTIVE AIR SUSPENSION, air or hydraulic leveling, rooms and warning devices. Holding the "STATUS" button on the "HOME" page or the "PAGE DOWN" button on the "STATUS" pages will scroll through the different "STATUS" pages.

**"HOME PAGE 2" BUTTON:** This button will bring up HOME PAGE 2 showing different functions available. HOME PAGE 3 will be accessed from HOME PAGE 2.

**NOTE: Some of the PANEL and SCREEN buttons will react as soon as they are pressed but some buttons will not react until they are released.**

**"ROOM" BUTTON:** This button will bring up the room control screen. Only room 1 and 4 are controlled with the LCD panel. Room 2 has a separate key switch panel.

# CONTROL IDENTIFICATION

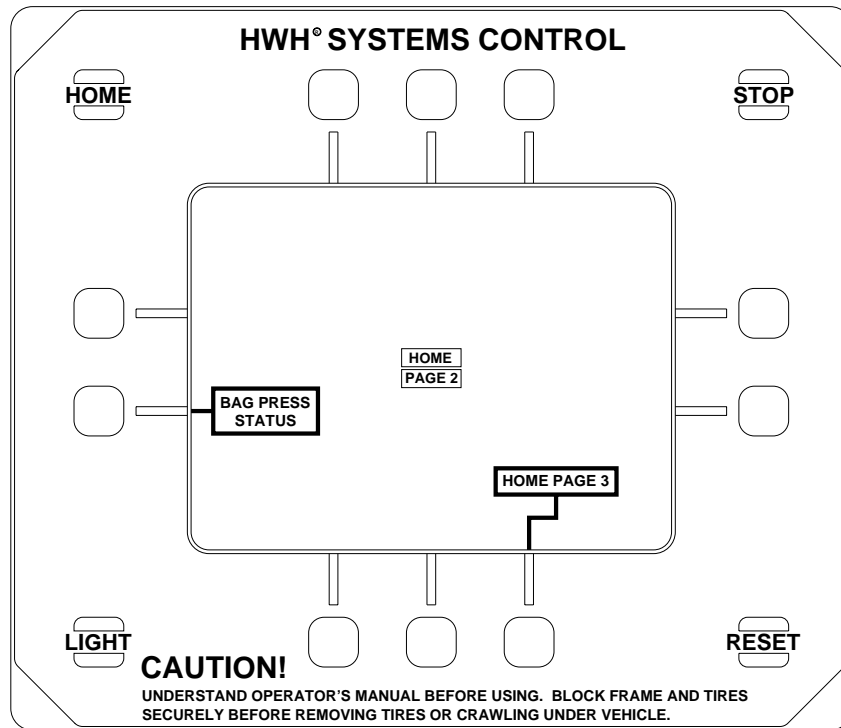

## HOME PAGE 2

### SCREEN BUTTONS

**"BAG PRESSURE STATUS" BUTTON:** This button will take you to the following screen.

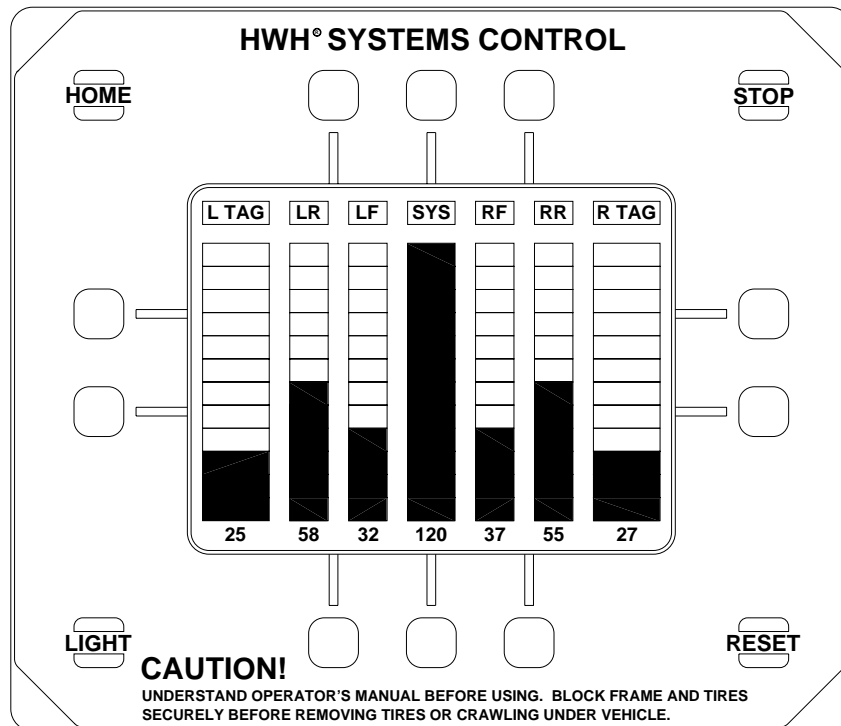

## BAG PRESSURE STATUS PAGE

**BAG PRESSURE STATUS PAGE:** Each column represents a particular bag or the system pressure. Each block represents a 10 p.s.i. increment. The numbers represent an approximate p.s.i. reading.

# CONTROL IDENTIFICATION

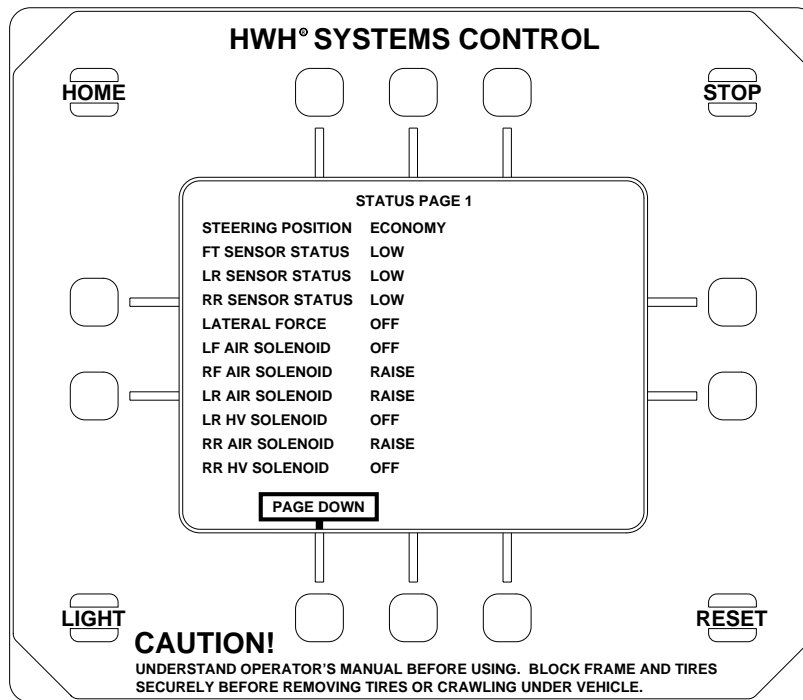

STATUS PAGE 1

## SCREEN BUTTONS

**"PAGE DOWN" BUTTON:** Use this button to switch from status screen to status screen.

## SCREEN TEXT

### "STEERING POSITION"

ECONOMY - Normal operating mode. Designed to conserve air (Straight roads)

FLY - Active response to driving conditions (Windy conditions or curvy roads)

### "FT SENSOR STATUS"

### "LR SENSOR STATUS"

### "RR SENSOR STATUS"

HIGH - Indicates selected sensor is ABOVE ideal set point.

LOW - Indicates selected sensor is BELOW ideal set point.

CHANGING - Sensor is "dithering" ABOVE and BELOW ideal set point.

INACTIVE - Indicates sensor is not changing state within allowed time.

### "LATERAL FORCE"

OFF - Vehicle is not experiencing high side loads.

ON - Vehicle is experiencing high side loads. Will keep system in "FLY" mode.

### "LF AIR SOLENOID"

### "RF AIR SOLENOID"

### "LR AIR SOLENOID"

### "LR HV SOLENOID"

### "RR AIR SOLENOID"

### "RR HV SOLENOID"

RAISE - Air supply is allowed into air bag. (Filling)

LOWER - Air supply is allowed out of air bag (Releasing)

OFF - No air is allowed into or out of air bag.

# CONTROL IDENTIFICATION

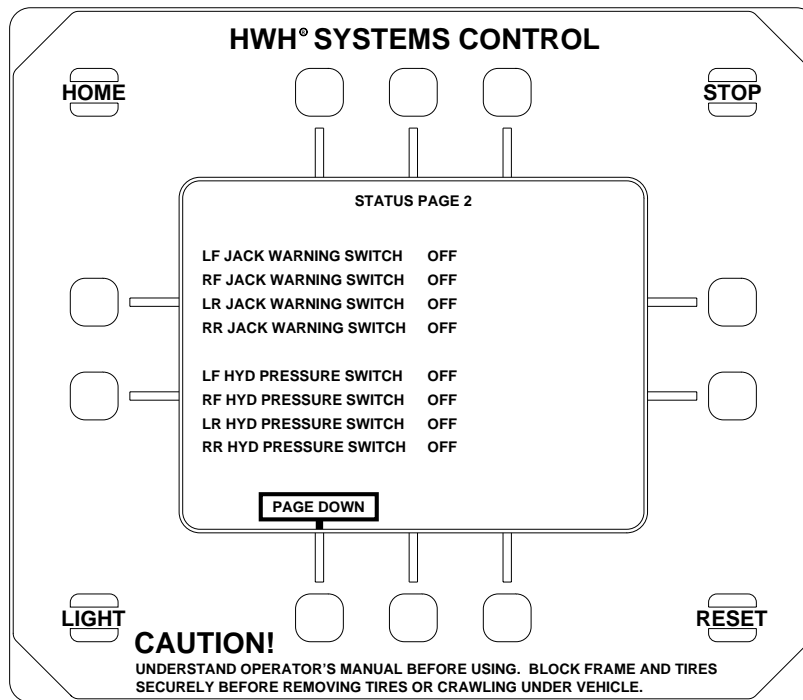

## STATUS PAGE 2

**NOTE:** This "STATUS PAGE" is specific to HWH hydraulic leveling systems ONLY.

### SCREEN BUTTONS

**"PAGE DOWN" BUTTON:** Use this button to switch from status screen to status screen.

### SCREEN TEXT

**"LF JACK WARNING SWITCH"**

**"RF JACK WARNING SWITCH"**

**"LR JACK WARNING SWITCH"**

**"RR JACK WARNING SWITCH"**

OFF - Jack is "FULLY" retracted

ON - Jack is extended

**"LF HYD PRESSURE SWITCH"**

**"RF HYD PRESSURE SWITCH"**

**"LR HYD PRESSURE SWITCH"**

**"RR HYD PRESSURE SWITCH"**

OFF - Jack has no load on it, It is not supporting weight.

ON - Jack has load on it, it is supporting weight.

# CONTROL IDENTIFICATION

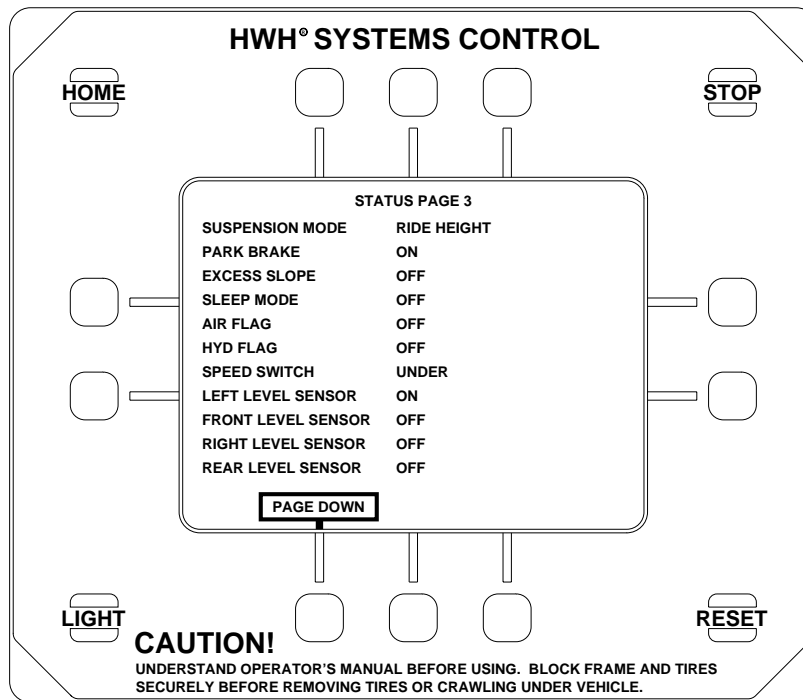

STATUS PAGE 3

## SCREEN BUTTONS

**"PAGE DOWN" BUTTON:** Use this button to switch from status screen to status screen.

## SCREEN TEXT

### "SUSPENSION MODE"

RIDE HEIGHT - System is in Active Air.

OFF - System is not in Active Air.

### "PARK BRAKE"

### "EXCESS SLOPE"

"SLEEP MODE" - Is in sleep mode air leveling.

"AIR FLAG" - Has been leveled using air.

"HYD FLAG" - Has been leveled using hydraulics.

OFF -

ON -

### "SPEED SWITCH"

UNDER - Vehicle is under speed. System will not enter "FLY" mode.

OVER - Vehicle is over speed. System will not enter "FLY" mode.

### "LEFT LEVEL SENSOR"

### "FRONT LEVEL SENSOR"

### "RIGHT LEVEL SENSOR"

### "REAR LEVEL SENSOR"

OFF -

ON -



# CONTROL IDENTIFICATION

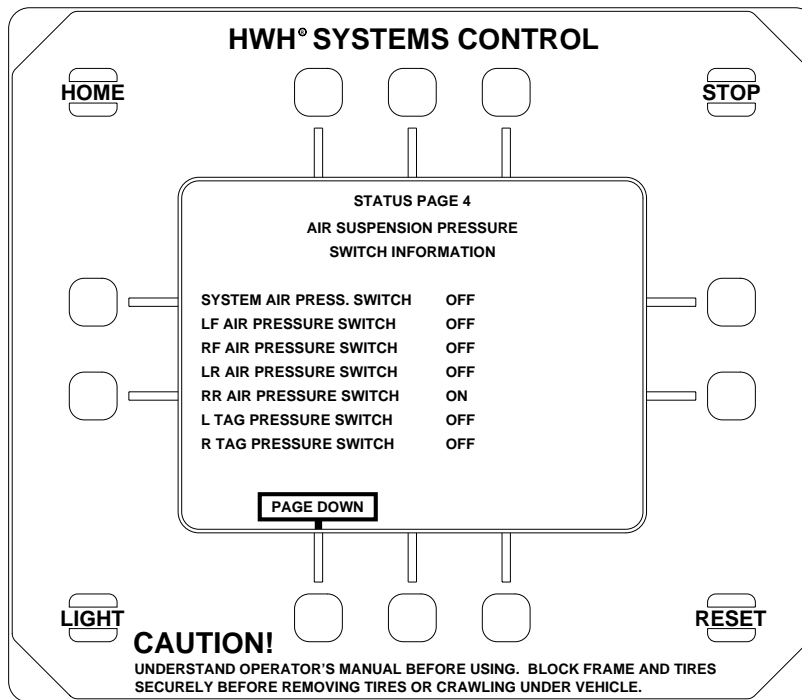

## STATUS PAGE 4

### SCREEN BUTTONS

**"PAGE DOWN" BUTTON:** Use this button to switch from status screen to status screen.

### SCREEN TEXT

**"SYSTEM AIR PRESS. SWITCH"**

**"LF AIR PRESSURE SWITCH"**

**"RF AIR PRESSURE SWITCH"**

**"LR AIR PRESSURE SWITCH"**

**"RR AIR PRESSURE SWITCH"**

**"L TAG PRESSURE SWITCH"**

**"R TAG PRESSURE SWITCH"**

OFF - Air bag does not have sufficient air pressure.

ON - Air bag does have sufficient air pressure.

## CONTROL IDENTIFICATION

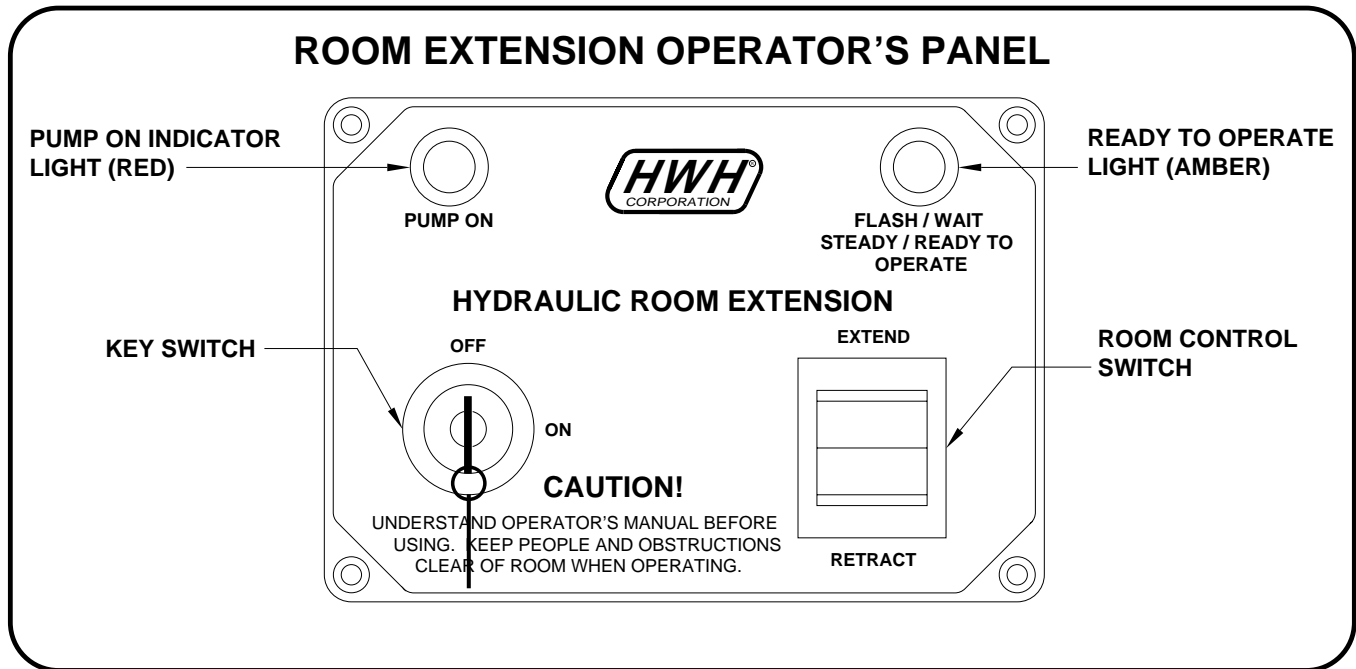

## CONTROL FUNCTIONS

**KEY SWITCH:** The KEY SWITCH controls power to the ROOM CONTROL SWITCH. When the KEY SWITCH is in the "ON" POSITION the room can be operated, and the key cannot be removed. When the KEY SWITCH is in the "OFF" position the room cannot be operated, and the key can be removed.

**NOTE:** Any time the KEY SWITCH is ON, the network will be active and will not power down.

**ROOM CONTROL SWITCH:** The ROOM CONTROL SWITCH is a two position momentary switch. Pressing the switch in the EXTEND POSITION will extend the room. Pressing the switch in the RETRACT POSITION will retract the room. Releasing the ROOM CONTROL SWITCH will halt the operation of the room.

**PUMP ON INDICATOR LIGHT:** This light will be on when the pump is running.

**READY TO OPERATE LIGHT:** This light will flash for 20 seconds while the air seal deflates, after the KEY SWITCH is turned on. It will then glow steady. Except for EXCESS SLOPE situations, the room cannot be extended or retracted if this light is flashing.

If the "EXCESS SLOPE" light on the leveling system control panel is on, the READY TO OPERATE light will flash continuously after the key switch is turned ON. The room will not extend. The room will retract if the room control switch is pushed to "RETRACT".

If the PARK BRAKE is not set, the READY TO OPERATE light will not turn on and flash when the KEY SWITCH is turned "ON".

If a RAISE or LOWER function of the Leveling System is in use, MANUAL or AUTOMATIC operation, the READY TO OPERATE light will flash if the KEY SWITCH is in the "ON" position. The room will not operate.

## MASTER WARNING LIGHT

This light is on the dash, separate from the control panels. It can be on only if the ignition key is in the "ON" position.

The light will be on if a HWH low air pressure switch is on, if the Leveling System is on, if the Leveling System is not in the TRAVEL mode, or if a room in limit switch is not made.

---

# OPERATING PROCEDURES

---

## GENERAL INSTRUCTIONS

Turn the ignition to the "ON" or "ACC" position to turn the SYSTEM CONTROL panel on.

Push the "HOME" button to return the SYSTEM CONTROL panel to HOME PAGE 1. Any function that is to be operated from the SYSTEM CONTROL panel can only be accessed from HOME PAGE 1. Individual screen functions are explained in this section.

The SYSTEM CONTROL screen will exhibit messages to the operator when there is a problem or malfunction in the system or when a function cannot be used. The "HOME" button must be pushed to acknowledge the message. The malfunction or situation must be corrected before proceeding.

**WARNING:** ANYTIME A "WARNING" MESSAGE APPEARS ON THE CONTROL SCREEN, IT IS THE OPERATORS RESPONSIBILITY TO CORRECT THE PROBLEM TO ENSURE SAFE OPERATION OF THE VEHICLE AND IT'S SYSTEMS.

Push the "STOP" button to stop any function. Pushing the "STOP" button will turn the SYSTEM CONTROL panel off.

**WARNING:** THE ACTIVE AIR SUSPENSION CANNOT FUNCTION IF THE SYSTEM CONTROL PANEL IS OFF.

The Air Leveling system or Hydraulic Leveling system cannot be activated if the park brake is not set.

**IMPORTANT:** If the vehicle is equipped with leveling jacks, do not use Manual or Automatic Air Leveling if the vehicle is supported on the leveling jacks. If Manual or Automatic Air Leveling has been used, do not use the leveling jacks.

Maintain adequate clearance in all directions for vehicle, room extensions and generator slide, doors, steps, etc.. Vehicle may move in any direction due to raising and lowering of vehicle during leveling, settling of vehicle, equipment malfunction etc..

## PREPARATION FOR TRAVEL

1. When the leveling system has been used, push the "AUTO STORE" button to return the system to the traveling mode.

**NOTE:** If the ignition is on and the park brake is released, the vehicle will return to ride height.

2. The SYSTEM CONTROL PANEL should be on when traveling.

3. Check that the vehicle is at the proper ride height for traveling.

**WARNING:** DO NOT RELY SOLELY UPON WARNING LIGHTS. IT IS THE OPERATOR'S RESPONSIBILITY TO CHECK THAT THE VEHICLE IS AT THE PROPER RIDE HEIGHT FOR TRAVELING. CONTACT MANUFACTURER TECHNICAL SERVICE BEFORE MOVING A VEHICLE THAT IS NOT AT PROPER TRAVEL HEIGHT.

## TAG LIFT

**IMPORTANT:** REFER TO THE VEHICLE MANUFACTURER FOR PROPER USE OF THE TAG LIFT FEATURE.

The ignition must be on, system air pressure must be at least approximately 50 psi and the vehicle cannot be traveling faster than approximately 10 mph for the tag lift feature to function.

To use the tag lift, push the "TAG LIFT" button. The "TAG LIFT" letters will turn white with a black background. The tag will remain in the lift position until the "TAG LIFT" button is pushed again or the vehicle exceeds approximately 10 mph. The "TAG LIFT" letters will turn black with a white background when the feature is off.

It is recommended to have the tag in the travel position before using the leveling system.

## TOWING

**WARNING:** THESE INSTRUCTIONS ARE FOR THE HWH ACTIVE AIR EQUIPMENT AND MANUAL INFLATION OF THE VEHICLE SUSPENSION AIR BAGS. CONSULT THE VEHICLE MANUFACTURER FOR COMPLETE TOWING INSTRUCTIONS.

There is a Schrader valve supplied for each air bag or sets of air bags on the vehicle suspension. They are labeled as follows: RIGHT FRONT - LEFT FRONT  
RIGHT DRIVE AXLE - LEFT DRIVE AXLE  
If Applicable: RIGHT TAG AXLE - LEFT TAG AXLE

**NOTE:** A Schrader valve is the same type of valve used to inflate or deflate a tire.

Consult the vehicle manufacturer for the specific location of the air bag Schrader valves and proper ride height for towing.

The HWH Active Air Control Panel must be OFF when using the manual air bag Schrader valves and during towing. Push the "STOP" button to turn the Active Air Control Panel OFF. The ignition key should also be "OFF" while towing.

**NOTE:** With the HWH Active Air System OFF during towing, the air bags may be controlled only from the Schrader valves. Monitor and maintain proper travel height during towing using the Schrader valves.

# OPERATING PROCEDURES

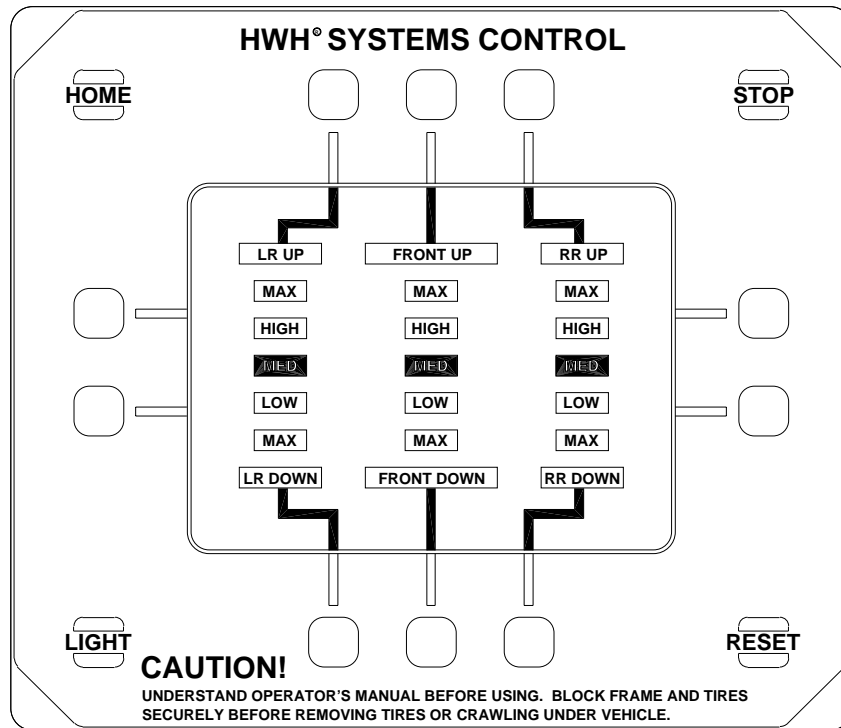

## SUSPENSION CONTROL

This screen is used to control the ride height of the vehicle while traveling or moving slowly.

Push UP or DOWN buttons to move the indicator light one position.

**NOTE: Pushing and holding a button will move an indicator one position only.**

### BUTTONS

**LR UP:** This will add air to the LEFT REAR air bags to raise the vehicle.

**FRONT UP:** This will add air to the FRONT air bags to raise the vehicle.

**RR UP:** This will add air to the RIGHT REAR air bags to raise the vehicle.

**LR DOWN:** This will exhaust air from the LEFT REAR air bags to lower the vehicle.

**FRONT DOWN:** This will exhaust air from the FRONT air bags to lower the vehicle.

**RR DOWN:** This will exhaust air from the RIGHT REAR air bags to lower the vehicle.

### INDICATORS

**MED:** When the indicator is in this position the suspension should be at the normal ride height for traveling.

**HIGH:** When the indicator is in this position the suspension should be approximately one (1) inch HIGHER than normal ride height.

**LOW:** When the indicator is in this position the suspension should be approximately one (1) inch LOWER than normal ride height.

**MAX:** When this indicator is in this position, the suspension will be at its MAXIMUM height if an UP button is used OR the suspension will be at its LOWEST point if a DOWN button is used.

**NOTE: The system monitors the transmission speed switch. The system will not allow the suspension to move to the MAX position, UP or DOWN when the vehicle is moving faster than the setting of the speed switch. This is usually between 5 MPH to 15 MPH.**

If the suspension is set to the MAX position, when the setting of the speed switch is exceeded, the system will default to the MED position. This would be normal ride height for the vehicle.

**IMPORTANT: Any time the RESET button is pushed while traveling, the system will default to the MED position, normal ride height.**

# OPERATING PROCEDURES

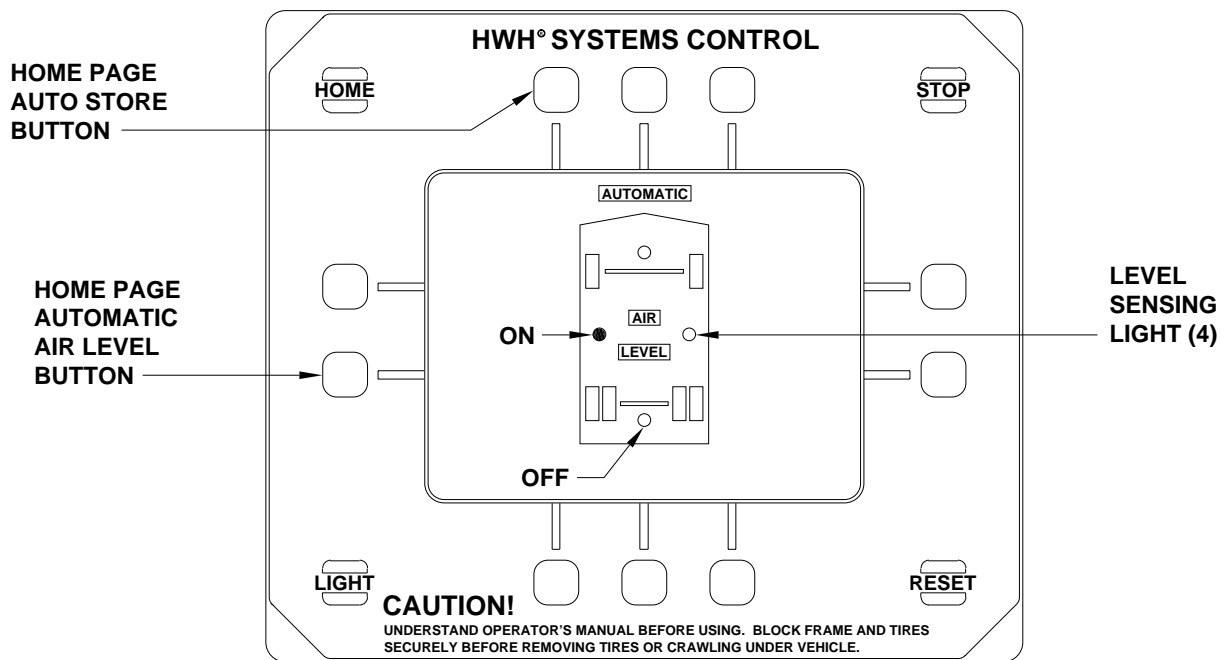

## AUTOMATIC AIR LEVELING

**WARNING:** KEEP PEOPLE AND OBJECTS CLEAR OF THE VEHICLE WHILE OPERATING THE HYDRAULIC LEVELING SYSTEM.

**IMPORTANT:** If the vehicle is equipped with leveling jacks, do not use Automatic Air Leveling if the vehicle is supported on the leveling jacks.

**NOTE:** It is recommended the tag axle is in the travel position before using the air leveling system. If the tag lift function is on, push the "TAG LIFT" button to turn the tag lift feature off.

The ignition key must be on and the park brake must be set to use automatic air leveling. If the ignition and/or the park brake are not on, a message will appear on the screen when the "AUTOMATIC AIR LEVEL" button is pushed. Push the "HOME" button and correct the problem before pushing the "AUTOMATIC AIR LEVEL" button again.

**NOTE:** Automatic leveling and automatic store can only be started when the "HOME" page is being displayed.

The system will level the vehicle according to level sensing lights. A lit level sensing light indicates that side, end or corner of the vehicle is low. When all level sensing lights are out the vehicle is level.

**NOTE:** Only one or two LEVEL SENSING lights may be on at one time.

1. Turn the ignition key on and set the park brake. Leaving the engine running during leveling is recommended. This will provide a better air supply for leveling. The vehicle will level with the engine shut off, however more time will be required for leveling.

2. Push the "AUTOMATIC AIR LEVEL" button on the HOME page. The AUTOMATIC AIR LEVEL page will appear. The air leveling process will begin. The system first exhaust air from all of the air bags. If a level position is not achieved by lowering the vehicle, the low side and/or end of the vehicle will be raised by adding air to the air bags. When all four yellow LEVEL SENSING lights are out the leveling is complete. The system will be in the SLEEP MODE. The screen will display a message for 45 seconds, then return to the HOME PAGE. The screen will turn off after 10 minutes if the ignition is turned off.

3. SLEEP MODE: If automatic air leveling is successful the system will be in the SLEEP MODE when all 4 level sensing lights go out. The system will remain in the SLEEP MODE until the "STOP" button is pushed or the park brake is released with the ignition on.

**NOTE:** The system will remain in the SLEEP MODE even with the screen off.

In the SLEEP MODE, the system will check the level sensing unit every 30 minutes. If an input is on continuously for one minute, the system will relevel the vehicle.

When releveling the vehicle the screen will turn on and display the AUTOMATIC LEVELING SCREEN. When all level lights are turned off, the system will return to the SLEEP MODE in the same manner as before.

**EXCESS SLOPE:** The system will attempt to level the vehicle for 15 to 20 minutes. If the automatic leveling attempt is not successful, the system will go into EXCESS SLOPE. The screen will display an EXCESS SLOPE message. This message will remain on the screen until the "HOME" button is pushed or if the ignition is off, the screen will turn off 10 minutes later.

# OPERATING PROCEDURES

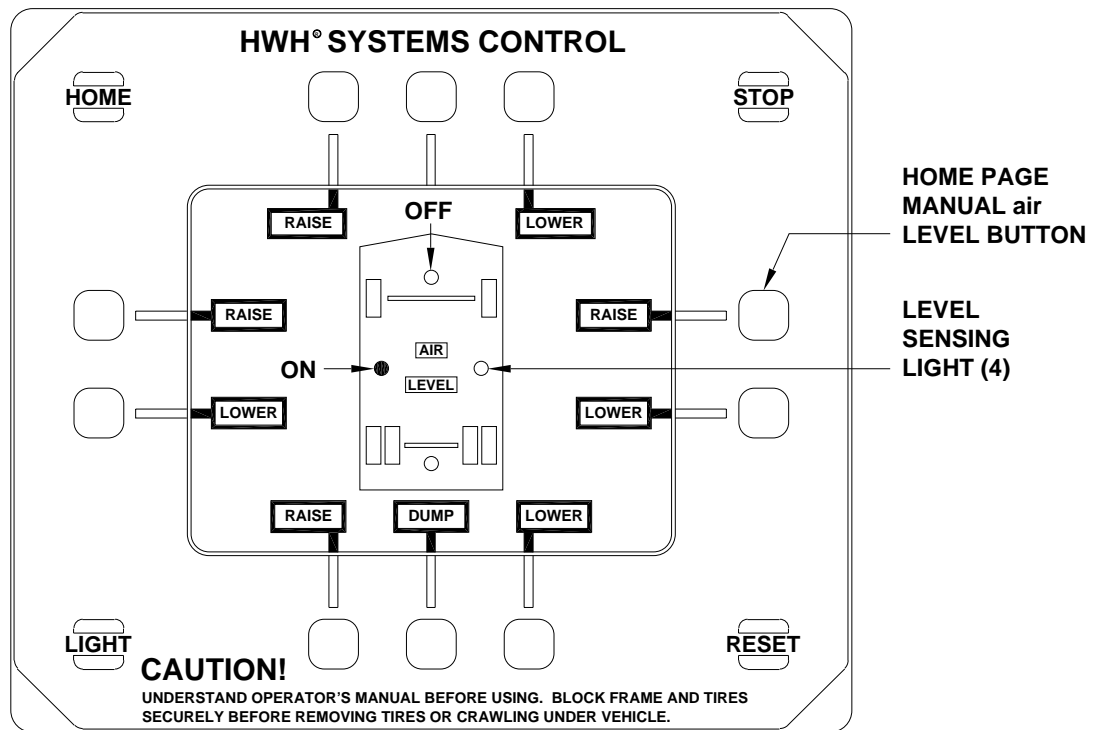

## MANUAL AIR LEVELING

**WARNING:** KEEP PEOPLE AND OBJECTS CLEAR OF THE VEHICLE WHILE OPERATING THE AIR LEVELING SYSTEM.

**IMPORTANT:** If the vehicle is equipped with leveling jacks, do not use Manual Air Leveling if the vehicle is supported on the leveling jacks.

**NOTE:** It is recommended the tag axle is in the travel position before using the air leveling system. If the tag lift function is on, push the "TAG LIFT" button to turn the tag lift feature off.

1. Place the ignition key in the "ON" position. Transmission must be in the proper position for parking and the park brake must be set to use MANUAL AIR LEVELING. Running the vehicle during leveling is recommended. This will provide a better air supply for leveling. The vehicle will level with the engine shut off, however more time will be required for leveling.

2. Push the "MANUAL AIR LEVEL" button located on "HOME PAGE 1". If the ignition and/or the park brake are not in the recommended positions, when the "MANUAL AIR LEVEL" button is pushed, a message will appear on the screen. Push the "HOME" button and correct the problem before pushing the "MANUAL AIR LEVEL" button again.

The LEVEL SENSING LIGHTS indicate which side, end or corner of the vehicle is low. No more than two level lights should be on at any one time. The vehicle is level when all LEVEL SENSING LIGHTS are off.

3. To level, use the "LOWER" buttons to exhaust air from the corresponding air bags. Use the "RAISE" buttons to add air to the corresponding air bags. The "RAISE" and "LOWER" buttons are momentary buttons. The bags will inflate or deflate only when the buttons are being pushed.

**NOTE:** Any side to side leveling should be done, if needed, before leveling the vehicle front to rear.

Try leveling the vehicle by lowering the high side or end (opposite of the lit level lights). If a level position is not achieved use the RAISE button to raise the low side or end.

**NOTE:** Pushing and holding the "DUMP" button will exhaust air from all bags of the vehicle suspension.

4. When the leveling procedure is complete, the engine can be turned off.

# OPERATING PROCEDURES

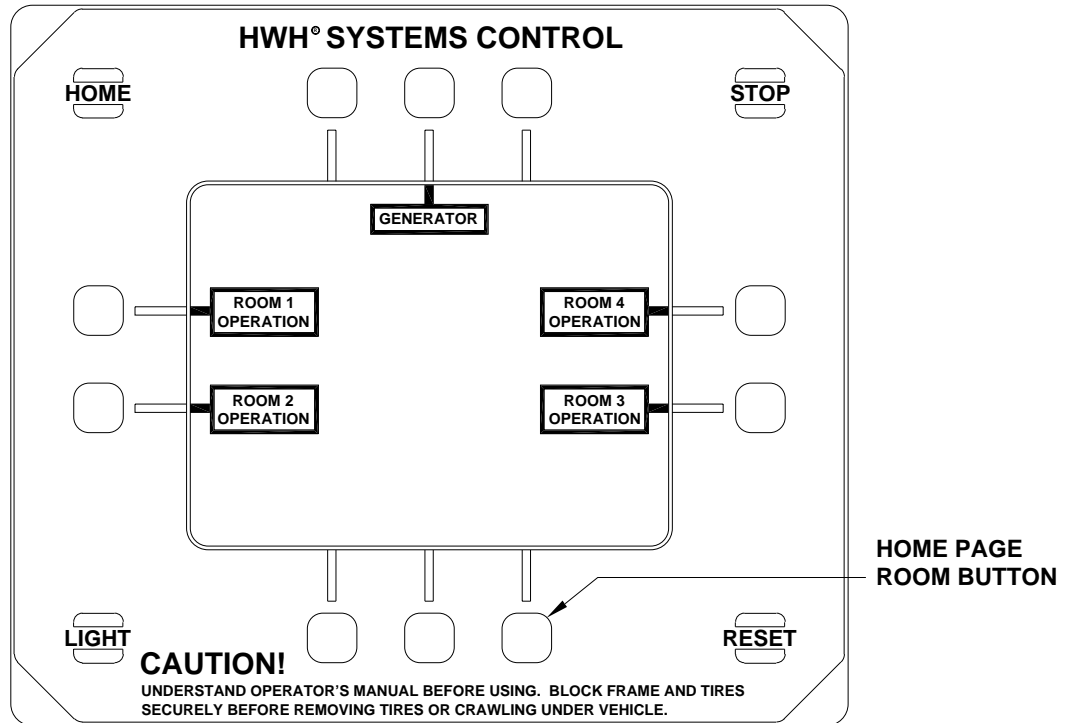

## ROOM SELECTION

1. Push the "ROOM" button on the "HOME" page to access the ROOM SELECTION page.

2. Push the corresponding button to select a room or generator slide that is to be operated. A ROOM OPERATION page will be displayed.

The park brake must be set to access the ROOM SELECTION page. If the park brake is not set, a message will appear when the ROOM button on the "HOME" page is pushed. The operator is directed to push the "HOME" button and correct the problem.

If an attempt to level the vehicle in an automatic leveling mode fails putting the system in an EXCESS SLOPE situation, rooms cannot be extended. Individual ROOM OPERATION pages can be accessed from the ROOM SELECTION page, but when the EXTEND button is pushed, a message will appear directing the operator to push the HOME button and resolve the EXCESS SLOPE situation.

Rooms can be retracted when the leveling system is in an EXCESS SLOPE situation.

**NOTE: See "EXCESS SLOPE" in the AUTOMATIC HYD or AIR procedures for detailed explanation of "EXCESS SLOPE".**

# OPERATING PROCEDURES

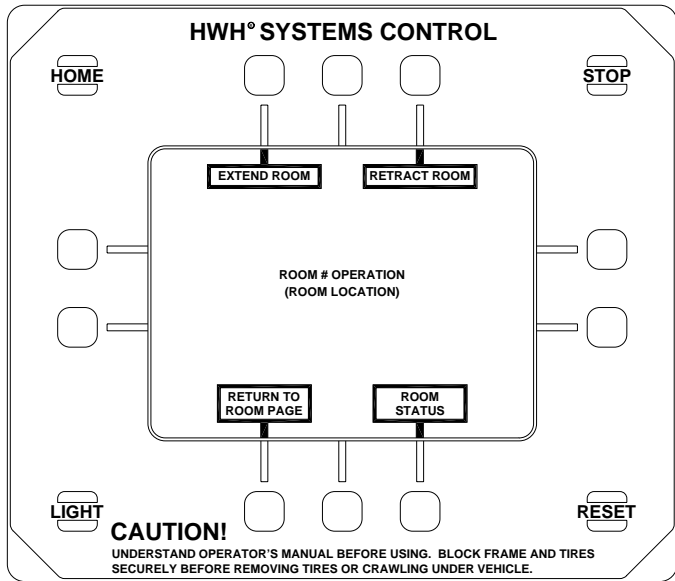

## ROOM EXTEND PROCEDURE

**WARNING:** OPERATING A ROOM WITH ANY ROOM LOCKING, CLAMPING OR MANUAL RETRACTING DEVICES ATTACHED OR ENGAGED CAN CAUSE PERSONAL INJURY AND VEHICLE DAMAGE. IT IS THE OPERATOR'S RESPONSIBILITY TO ENSURE THAT ALL ROOM LOCKING, CLAMPING OR MANUAL RETRACTING DEVICES ARE DETACHED OR DISENGAGED BEFORE OPERATING THE ROOM.

It is recommended to complete the Leveling Procedure before operating room extensions.

1. Unlock all room-locking devices.

**NOTE:** If a MANUAL RETRACT device is attached to the room remove it before extending the room.

**WARNING:** KEEP PEOPLE AND OBSTRUCTIONS CLEAR OF ROOM WHEN OPERATING.

**NOTE:** Make sure there is adequate clearance to fully extend the room.

2. To extend the room, press and hold the EXTEND ROOM button until the room is fully extended. The EXTEND ROOM LIGHT will flash while the button is being pushed.

**NOTE:** Hold the switch to "EXTEND" three or four seconds after the room is fully extended. This assures proper pressurization of the cylinders. **During normal operation of the room, do not reverse direction of the room until the room is fully extended. If necessary, the direction of the room may be reversed, but watch for binding of the room. If the direction of the room has been reversed, DO NOT re-extend the room until the room has been fully extended.**

**IMPORTANT:** Do not hold the ROOM CONTROL SWITCH in the "EXTEND" position for more than ten seconds after the room is fully extended or stops moving. **If either side of the room stops moving, release the room control switch immediately. DO NOT force the room. DO NOT reverse direction of the room, contact HWH Customer Service for assistance 1-800-321-3494.**

**NOTE:** Releasing the ROOM CONTROL SWITCH will halt the operation of the room.

## ROOM RETRACT PROCEDURE

**WARNING:** KEEP PEOPLE AND OBSTRUCTIONS CLEAR OF ROOM WHEN OPERATING.

It is recommended to retract room extensions before retracting the hydraulic leveling system.

1. To retract the room press and hold the RETRACT ROOM button until the room is fully retracted. The RETRACT ROOM light will flash while the button is being pushed.

**NOTE:** Hold the switch to "RETRACT" three or four seconds after the room is fully retracted. This assures proper pressurization of the cylinders. **During normal operation of the room, do not reverse direction of the room until the room is fully retracted. If necessary, the direction of the room may be reversed, but watch for binding of the room. If the direction of the room has been reversed, DO NOT retract the room until the room has been fully retracted.**

**IMPORTANT:** Do not hold the ROOM CONTROL SWITCH in the "RETRACT" position for more than ten seconds after the room is fully retracted or stops moving. **If either side of the room stops moving, release the room control switch immediately. DO NOT force the room. DO NOT reverse direction of the room, contact HWH Customer Service for assistance 1-800-321-3494.**

**NOTE:** Releasing the ROOM CONTROL SWITCH will halt the operation of the room.

2. Engage all room-locking devices.
3. If the room will not retract see the MANUAL ROOM RETRACT PROCEDURE.

**IMPORTANT:** Room-locking devices should be locked while traveling.

**RETURN TO ROOM PAGE BUTTON:** This button will return the screen to the ROOM SELECTION page.

**ROOM STATUS BUTTON:** This button will display a page showing the status of assorted room or lock limit switches being used if applicable.



---

# OPERATING PROCEDURES

---

## ROOM EXTEND PROCEDURE - HWH KEY SWITCH PANEL

**IMPORTANT:** It is recommended to level the vehicle before extending the room.

1. The park brake must be set for the room to be operated. If the "EXCESS SLOPE" light on the touch panel is on, the room cannot be extended.

**Make sure the door or a window is open while extending a room.**

**IMPORTANT:** If the "EXCESS SLOPE" light is ON, the vehicle must be re-leveled so all yellow LEVEL indicator lights on the touch panel are OFF before the room can be extended. If any of the four yellow LEVEL indicator lights cannot be put out, the vehicle should be moved to a more level location before using the room extension.

**WARNING:** KEEP PEOPLE AND OBSTRUCTIONS CLEAR OF ROOM WHEN OPERATING.

**NOTE:** Make sure there is adequate clearance to fully extend the room.

2. Insert the KEY into the KEY SWITCH on the room extension operator's panel and turn it to the "ON" position. The READY TO OPERATE light will flash. When the amber light is on steady the room can be operated.

**NOTE:** Anytime the KEY SWITCH is on, the room air seal will deflate.

**NOTE:** If the Leveling System is being operated, the room will not extend. If the room panel KEY SWITCH is on, the "READY TO OPERATE" light will flash while the Leveling System is being operated.

3. To extend the room, push and hold the ROOM CONTROL SWITCH in the extend position. The red PUMP ON light will come on. There may be a delay of several seconds (no more than 10 seconds) before the PUMP ON light comes on after the switch is pushed. When the room is fully extended, the pump will automatically shut off. The red PUMP ON light will go out. Do not release the ROOM CONTROL SWITCH, until the red PUMP ON light goes out. **If the red PUMP ON light remains on 30 seconds after the room is fully extended release the room control switch.**

**NOTE:** The room is equipped with an air seal, the air seal is monitored by a vacuum switch to make sure the air seal is deflated. This may cause a delay in room operation when the Room Control switch is pushed. While the Room Control Switch is being pushed a loss of vacuum in the air seal will not halt the movement of the room unless the Room Control switch is released. The Room Control switch will not work until the vacuum switch is made.

**NOTE:** Under normal operation of the room, the direction of movement should not be reversed. If the movement of the room must be reversed, do not try to re-extend the room until the room has been fully retracted.

**IMPORTANT:** IF EITHER SIDE OF THE ROOM STOPS MOVING, RELEASE THE ROOM CONTROL SWITCH IMMEDIATELY. THE ROOM OPERATION WILL HALT. DO NOT FORCE THE ROOM. DO NOT REVERSE DIRECTION OF THE ROOM. BINDING OF ROOM CAN CAUSE ROOM DAMAGE. CONTACT HWH CORPORATION CUSTOMER SERVICE FOR ASSISTANCE.

**NOTE:** The READY TO OPERATE light will flash when the room control switch is pushed if the "EXCESS SLOPE" light on the Leveling System panel is ON. The room will not extend.

4. Turn the KEY SWITCH to the "OFF" position and remove the key. The READY TO OPERATE light will go out. The air seal will inflate.

**NOTE:** If the KEY SWITCH is left "ON" the air seal will not inflate and the Network will stay active and not power down.

---

# OPERATING PROCEDURES

---

## ROOM RETRACT PROCEDURE - HWH KEY SWITCH PANEL

**WARNING:** KEEP PEOPLE AND OBSTRUCTIONS CLEAR OF ROOM WHEN OPERATING.

Make sure the door or a window is open while extending a room.

1. The park brake must be set for the room to be operated.

**IMPORTANT:** It is recommended that the coach is level before retracting the room.

2. Insert the KEY into the KEY SWITCH on the room extension operator's panel and turn it to the "ON" position. The air seal will deflate. The READY TO OPERATE light will flash. When the amber light is on steady the room can be operated.

**NOTE:** If the Leveling System is being operated, the room will not retract. If the room panel KEY SWITCH is on, the "READY TO OPERATE" light will flash while the Leveling System is being operated.

3. To retract the room, push and hold the ROOM CONTROL SWITCH in the retract position. The red PUMP ON light will come on. There may be a delay of several seconds (no more than 10 seconds) before the PUMP ON light comes on after the switch is pushed. When the room is fully retracted, the pump will automatically shut off. The red PUMP ON light will go out. Do not release the ROOM CONTROL SWITCH, until the red PUMP ON light goes out. **If the red PUMP ON light remains on 30 seconds after the room is fully retracted release the room control switch.**

**NOTE:** The room is equipped with an air seal, the air seal is monitored by a vacuum switch to make sure the air seal is deflated. This may cause a delay in room operation when the Room Control switch is pushed. While the Room Control Switch is being pushed a loss of vacuum in the air seal will not halt the movement of the room unless the Room Control switch is released. The Room Control switch will not work until the vacuum switch is made.

**NOTE:** Under normal operation of the room, the direction of movement should not be reversed. If the movement of the room must be reversed, do not try to retract the room until the room has been fully extended.

**IMPORTANT:** IF EITHER SIDE OF THE ROOM STOPS MOVING, RELEASE THE ROOM CONTROL SWITCH IMMEDIATELY. THE ROOM OPERATION WILL HALT. DO NOT FORCE THE ROOM. DO NOT REVERSE DIRECTION OF THE ROOM. BINDING OF ROOM CAN CAUSE ROOM DAMAGE. CONTACT HWH CORPORATION CUSTOMER SERVICE FOR ASSISTANCE.

4. Turn the KEY SWITCH to the "OFF" position and remove the key. The READY TO OPERATE light will go out. The air seal will inflate.

**NOTE:** If the KEY SWITCH is left "ON" the air seal will not inflate and the Network will stay active and not power down.

**IN THE EVENT OF THE FAILURE OF THE ROOM TO RETRACT, CONTACT HWH CORPORATION CUSTOMER SERVICE AT 1-800-321-3494 FOR ASSISTANCE.**

---

# OPERATING PROCEDURES

---

## STEP COVER EXTEND PROCEDURE

**WARNING:** KEEP PEOPLE AND OBSTRUCTIONS CLEAR OF COVER WHEN OPERATING.

**NOTE:** Make sure there is adequate clearance to fully extend the cover.

To extend the cover, press and hold the STEP COVER CONTROL SWITCH in the "EXTEND" position. When the cover is fully extended, release the STEP COVER CONTROL SWITCH.

**IMPORTANT:** If the pump is running, DO NOT hold the STEP COVER CONTROL SWITCH in the "EXTEND" position for more than ten seconds after the cover is fully extended or stops moving. DO NOT FORCE THE COVER.

**NOTE:** Releasing the STEP COVER SLIDE CONTROL SWITCH will halt the operation of the cover.

## STEP COVER RETRACT PROCEDURE

To retract the slide, press and hold the STEP COVER CONTROL SWITCH in the "RETRACT" position. When the cover is fully retracted, release the COVER CONTROL SWITCH.

**IMPORTANT:** If the pump is running, DO NOT hold the STEP COVER CONTROL SWITCH in the "RETRACT" position for more than ten seconds after the cover is fully retracted or stops moving. DO NOT FORCE THE COVER.

**NOTE:** Releasing the STEP COVER SLIDE CONTROL SWITCH will halt the operation of the cover.

MANUAL STEP COVER RETRACT PROCEDURE: SEE HYDRAULIC CONNECTION DIAGRAM - STEP COVER MANIFOLD AND CYLINDER.

---

# OPERATING PROCEDURES

---

## GENERATOR SLIDE EXTEND PROCEDURE

**WARNING:** KEEP PEOPLE AND OBSTRUCTIONS CLEAR OF SLIDE WHEN OPERATING.

**NOTE:** Make sure there is adequate clearance to fully extend the slide.

**1. THE PARK BRAKE MUST BE SET FOR THE SLIDE TO OPERATE.**

2. To extend the slide, press and hold the GENERATOR SLIDE CONTROL SWITCH in the "EXTEND" position. When the slide is fully extended, release the GENERATOR SLIDE CONTROL SWITCH.

**IMPORTANT:** Do not hold the GENERATOR SLIDE CONTROL SWITCH in the "EXTEND" position for more than ten seconds after the slide is fully extended or stops moving. **DO NOT FORCE THE SLIDE.**

**NOTE:** Releasing the GENERATOR SLIDE CONTROL SWITCH will halt the operation of the slide.

## GENERATOR SLIDE RETRACT PROCEDURE

**1. THE PARK BRAKE MUST BE SET FOR THE SLIDE TO OPERATE.**

2. To retract the slide, press and hold the GENERATOR SLIDE CONTROL SWITCH in the "RETRACT" position. When the slide is fully retracted, release the GENERATOR SLIDE CONTROL SWITCH.

**IMPORTANT:** Do not hold the GENERATOR SLIDE CONTROL SWITCH in the "RETRACT" position for more than ten seconds after the slide is fully retracted or stops moving. **DO NOT FORCE THE SLIDE.**

**NOTE:** Releasing the GENERATOR SLIDE CONTROL SWITCH will halt the operation of the slide.

3. If the slide will not retract see the MANUAL SLIDE RETRACT PROCEDURE.

# MANUAL ROOM AND GENERATOR SLIDE RETRACT PROCEDURE

(USE ONLY WHEN THE ROOM WILL NOT RETRACT WITH THE ROOM CONTROL SWITCH)

## OVERVIEW

The room can be retracted manually if a hydraulic or electric failure prevents the room from being retracted using the CONTROL SWITCH. For normal retract sequence see the ROOM SLIDE RETRACT PROCEDURES. Refer to the vehicle manufacturer for storage location of the retract device and information for connecting the device to the room.

**IMPORTANT:** If the vehicle is not equipped with a winch, DO NOT use other pulling devices to retract the room. Follow steps 2 and 3 and try pushing the room in. Contact the vehicle manufacturer or HWH Customer Service at 1-800-321-3494 or 563-724-3396 for assistance.

**WARNING:** A MANUAL RETRACT WINCH PROVIDED BY HWH IS EQUIPPED FOR MANUALLY RETRACTING THE ROOM ONLY. IT IS NOT TO BE USED FOR LIFTING OR ANY OTHER APPLICATION. HIGH FORCES ARE CREATED WHEN USING A WINCH, CREATING POTENTIAL SAFETY HAZARDS. FAILURE TO FOLLOW ALL WARNINGS AND INSTRUCTIONS MAY CAUSE FAILURE OF THE MANUAL RETRACT WINCH OR CONNECTIONS RESULTING IN DAMAGE OR PERSONAL INJURY. MAINTAIN A FIRM GRIP ON THE WINCH HANDLE AT ALL TIMES. NEVER RELEASE THE HANDLE WHEN RATCHET LEVER IS IN THE OFF POSITION AND THE WINCH IS LOADED. THE WINCH HANDLE COULD SPIN VIOLENTLY AND CAUSE PERSONAL INJURY. CHECK THE WINCH AND STRAPS FOR DAMAGE OR WEAR, AND CHECK FOR PROPER RATCHET OPERATION ON EACH USE OF THE WINCH. DO NOT USE IF DAMAGED OR WORN.

1. Retract jacks following the LEVELING SYSTEM RETRACT PROCEDURE.

**NOTE :** When manually retracting the room, it is recommended the jacks are retracted before retracting the room.

2. Locate the HYDRAULIC PUMP and/or MANIFOLD unit. Some systems may have a remote manifold.

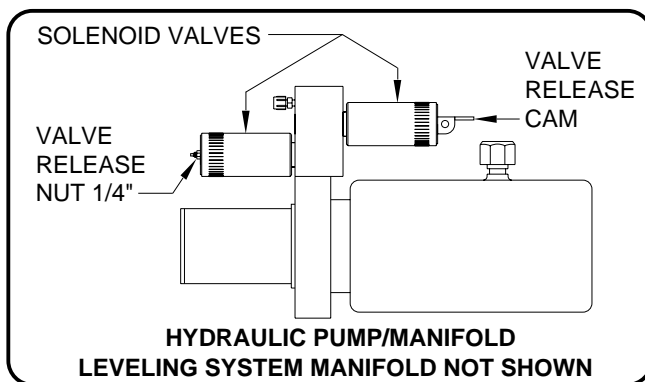

3. Open Nut Style Solenoid Valves by slowly turning the valve release nut counter clockwise using a 1/4" nut driver.

**IMPORTANT:** Only open the valves enough to retract the room. DO NOT turn the release nuts more than 4 and 1/2 turns. Turning the nuts more could damage the valves.

Open Cam Style Solenoid Valves by following the instructions located on the last page of this manual MP84.9999.

**NOTE:** The room may move slightly as the SOLENOID VALVES are opened and internal pressure is released.

4. Locate the MANUAL RETRACT DEVICE and connect it to the room according to the vehicle manufacturer's instructions. To extend a WINCH STRAP firmly grasp WINCH HANDLE, place RATCHET LEVER in its OFF position, and slowly rotate the WINCH HANDLE counter clockwise, keeping a firm grip on the handle. When enough WINCH STRAP is extended, place the RATCHET LEVER in its ON position and slowly rotate the WINCH HANDLE clockwise until the RATCHET LEVER locks.

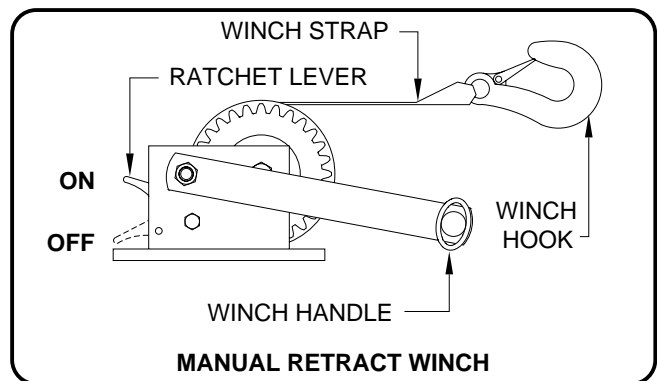

5. Slowly winch the room in by turning the WINCH HANDLE clockwise. The RATCHET LEVER should produce a loud, sharp, clicking noise.

**NOTE:** Winching the room in quickly will raise pressure in the hydraulic fluid and make winching more difficult.

**WARNING:** OPERATE THE MANUAL RETRACT WINCH BY HAND POWER ONLY. IF THE WINCH CANNOT BE CRANKED EASILY WITH ONE HAND IT IS PROBABLY OVERLOADED. IF WINCHING BECOMES TO DIFFICULT STOP AND CHECK FOR OBSTRUCTIONS/RESTRICTIONS ON THE ROOM AND ROOM EXTENSION MECHANISM.

6. When the room is fully retracted, engage the room locking devices. Leave the retract winch engaged and the solenoid valves open.

**WARNING:** THE ROOM EXTENSION SOLENOID VALVE RELEASE MUST BE IN THE OPEN POSITION WHEN THE MANUAL RETRACT WINCH IS ENGAGED.

7. The system should be repaired before using again.

**NOTE:** After repairs are made, when closing the VALVE RELEASE NUTS, do not over tighten the nuts.

# OPERATING PROCEDURES

## "UNIVERSAL STRAIGHT OUT" ROOM EXTENSION MECHANISM

### MANUAL ROOM RETRACTION PROCEDURES

1. Determine which extend and retract solenoid valves are assigned to the room. Manually open the valve release nuts for the extend and retract solenoid valves by turning the 1/4" release nuts counter clockwise 4 and 1/2 turns. Turning the nuts more could damage the valves. If equipped with valve release cams, move the cams to the OPEN position.

**NOTE: The breather cap dip stick is also a 1/4" nut driver.**

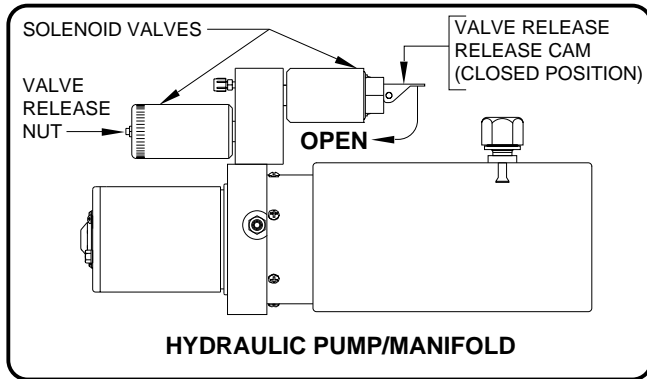

2. Start both threaded rods until resistance is met, one for the front and one for the rear mechanism should be provided.

**NOTE: For location of the threaded rods and to access the threaded blocks refer to vehicle manufacturer.**

3. **Do Not use an impact wrench.** Using wrench provided, a personal wrench or a tire iron with a 1-1/8" opening rotate either mechanism's threaded rod clockwise 6 complete turns.

4. Move to the other room extension mechanism, rotate the threaded rod clockwise 12 complete turns.

5. Return to the first room extension mechanism and rotate the threaded rod clockwise 12 complete turns.

6. Repeat steps 4 and 5 alternating from mechanism to mechanism rotating each threaded rod 12 complete turns until room is sealed. (DO NOT exceed 15 ft.lbs) Make sure the room does not bind.

**IMPORTANT: If at any stage something is not understood or if the room begins to bind DO NOT force the room, contact HWH Customer Service for assistance 1-800-321-3494.**

**NOTE: Leave the solenoid valves open and the threaded rods in place until the room has been serviced.**

**IMPORTANT: DO NOT EXTEND THE ROOM UNTIL THE ROOM HAS BEEN SERVICED. ANY SOLENOID VALVES LEFT OPEN SHOULD BE CLOSED AND THE THREADED RODS SHOULD BE COMPLETELY REMOVED.**

**NOTE: If there is not enough room to remove both threaded rods completely, alternate backing the threaded rods out and slightly extending the room. Be careful to not extend the room so far that the threaded rods impact the coach wall or the mechanism.**

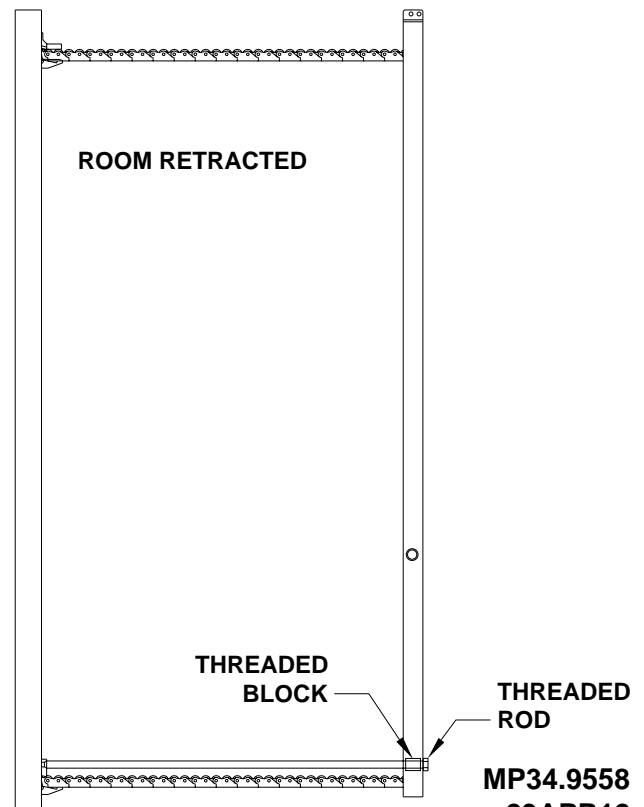
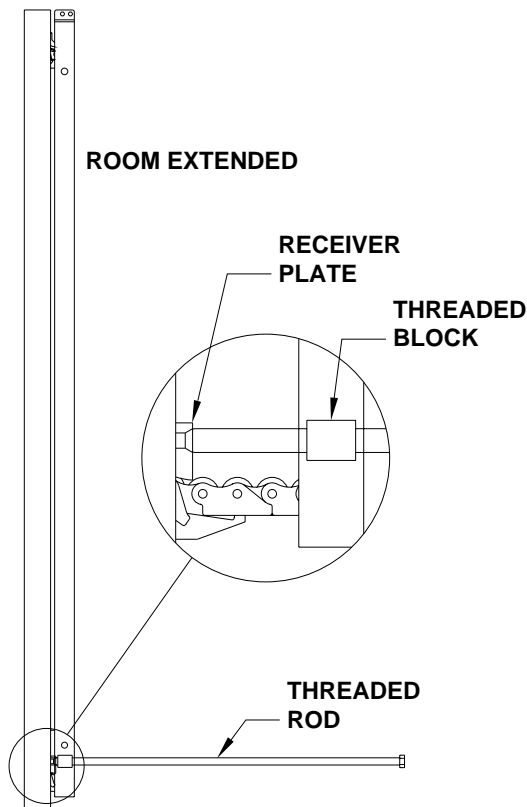

# SENSING UNIT MAINTENANCE/SERVICE

## SENSING UNIT ACCURACY TOLERANCE

The sensing unit has an accuracy tolerance of  $\pm 5.4$  inches front to rear and  $\pm 1$  inch side to side on a 36 foot vehicle. Typical leveling results will be better.

## SENSING UNIT ADJUSTMENT

Level the vehicle by placing a bubble level in the center of the freezer floor or upon whichever surface within the vehicle that is to be level. Using the Leveling System and the bubble level, ignoring the yellow LEVEL lights on the Touch Panel, level the vehicle until the bubble is centered.

With the vehicle level according to the bubble level, if there are no yellow lights lit on the Touch Panel, the sensing unit is properly adjusted. If there are yellow LEVEL lights lit on the Touch Panel, manual adjustments to the Sensing Unit are needed. A Phillips screw driver or sockets w/driver or box end wrenches of 7/8, 3/4, 1/2, 5/16 or 1/4 sizes will be needed.

The Sensing Unit is mounted inside the Control Box. The Control Box is mounted to the power unit/valve assembly.

There are four LED's on the Sensing Unit, A,B,C and D. Refer to the drawing below. The Sensing Unit is adjusted by turning the adjustment nut to turn out LED's B and D. The adjustment screw will turn out LED's A and C. If the adjustment nut has to be turned more than 1/2 flat or the adjustment screw has to be turned more than 3/4 turn to turn the LED out, there may be a problem with the Sensing Unit or the mounting of the Control Box. If two LED's are on, it is best to make the B-D adjustments first, then hold the adjustment nut from moving while making the A-C adjustment.

**NOTE: If opposing LED's are lit, there is a problem with the Sensing Unit.**

**If LED (A) is lit: Turn the adjustment screw COUNTER CLOCKWISE until the LED is off.**

**If LED (C) is lit: Turn the adjustment screw CLOCKWISE until the LED is off.**

**If LED (B) is lit: Turn the adjustment nut COUNTER CLOCKWISE until the LED is off.**

**If LED (D) is lit: Turn the adjustment nut CLOCKWISE until the LED is off.**

**IMPORTANT: When all 4 LED's are off, move the vehicle to an unlevel position so one or two yellow lights are on. Level the vehicle according to the yellow LEVEL lights. Recheck the level. If more adjustment is needed, DO NOT try to adjust the sensing unit until the yellow level lights go out, instead just "tweak" the sensing unit, ignoring the LED's on the sensing unit.**

**Example: After the initial adjustment and releveling the vehicle, the front is still low. This means the front yellow level light is turning off too soon. Determine which sensing unit light is the front light, A-B-C or D. Move the adjustment for that light very, very, slightly in the OPPOSITE direction that is given in the above instructions for LED's A, B, C, and D. This will allow the front yellow light to stay on slightly longer to bring the front up more. Again, unlevel the vehicle then relevel the vehicle using the yellow level lights on the touch panel. Recheck with a level. Repeat the "tweaking" process until the system levels the vehicle properly.**

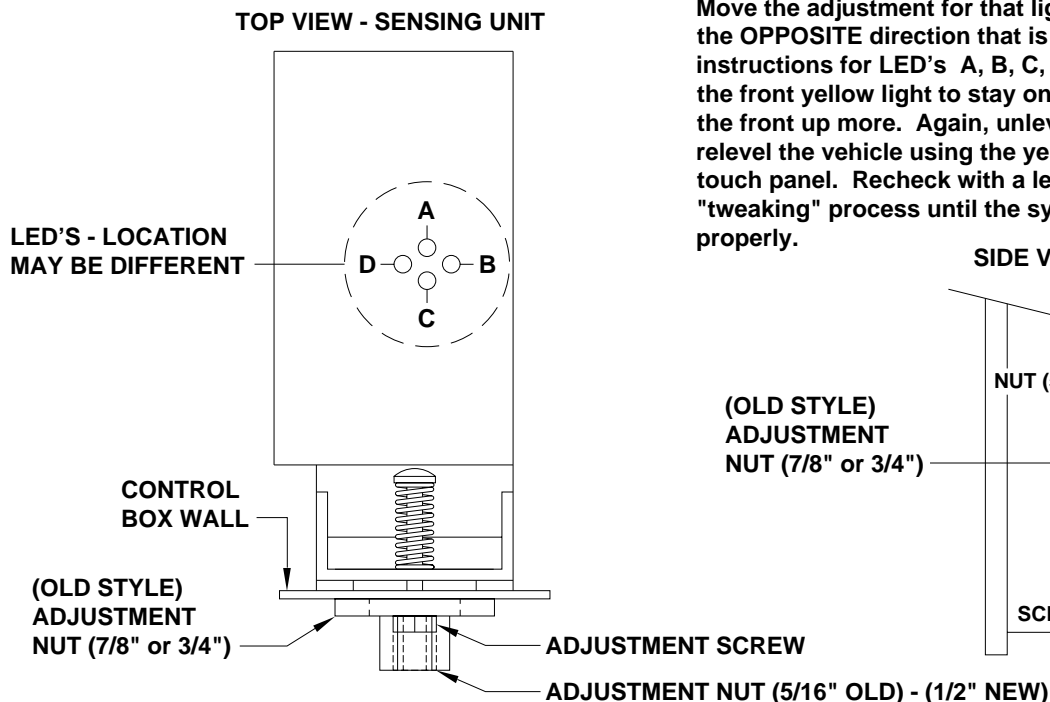

---

# MAINTENANCE

---

## PROCEDURE FOR WEIGHING VEHICLE, CHECKING RIDE HEIGHT MEASUREMENTS, AND ALIGNING THE WHEELS

**WARNING:** DO NOT CRAWL UNDER A VEHICLE UNLESS THE FRAME OF THE VEHICLE IS PROPERLY SUPPORTED. DO NOT USE THE AIR SUSPENSION OR LEVELING JACKS TO SUPPORT THE VEHICLE WHILE UNDER THE VEHICLE.

1. Chock wheels.
2. Park brake off.
3. Transmission in neutral.
4. Enter SUSPENSION Screen and select MAX low on all 3 columns (LR, FNT, RR).
5. Press HOME.
6. Select PRESSURE screen and verify all air bags display zero.
7. Press RESET.
8. Press HOME to acknowledge reset had been pressed.
9. Wait for "INITIALIZING" to stop flashing.
10. Wait an additional 2 minutes.

The vehicle can now be weighed, the ride height of the suspension can be checked, or the wheels can be aligned.

Refer to the vehicle or chassis manufacturer for information concerning axle weights or ride height specifications and location on the chassis for measuring ride height.



# HYDRAULIC CONNECTION DIAGRAM STEP COVER MANIFOLD AND CYLINDER

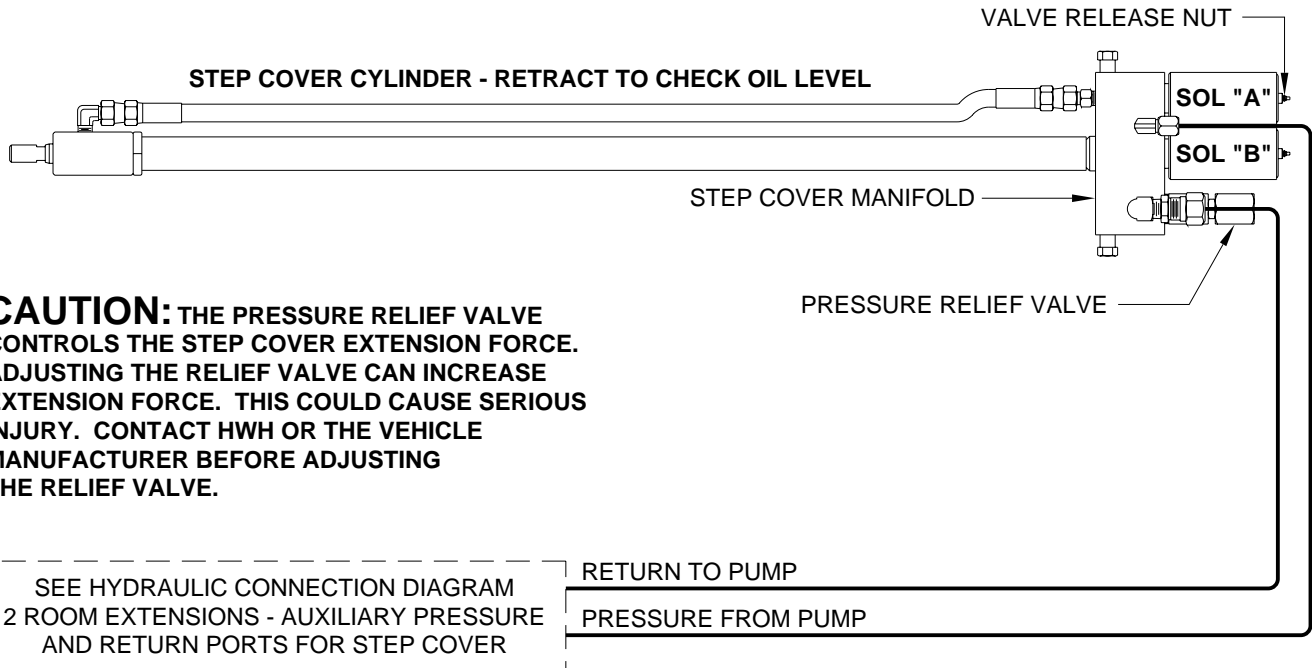

**CAUTION:** THE PRESSURE RELIEF VALVE CONTROLS THE STEP COVER EXTENSION FORCE. ADJUSTING THE RELIEF VALVE CAN INCREASE EXTENSION FORCE. THIS COULD CAUSE SERIOUS INJURY. CONTACT HWH OR THE VEHICLE MANUFACTURER BEFORE ADJUSTING THE RELIEF VALVE.

**NOTE:** TO EXTEND THE STEP COVER CYLINDER, SOLENOID (A) IS OPENED.

TO RETRACT THE STEP COVER CYLINDER, SOLENOID (B) IS OPENED.

## MANUAL STEP COVER RETRACT PROCEDURE

**NOTE:** THE MANUAL STEP COVER RETRACT PROCEDURE IS TO BE USED IF THE STEP COVER CANNOT BE RETRACTED WITH THE STEP COVER SWITCH.

The step cover can be retracted simply by pushing it back. It will take between 100 and 200 pounds of force to push the step cover back. If the solenoid valves are accessible, the step cover will push back easier if the valves are opened. Use a 1/4" nut driver to turn the valve release nuts counter-

clockwise no more than four and one half full turns. After opening the valves push the cover back several inches then wait about four seconds before pushing again. This will allow back pressure to relax as the step cover is pushed in. Close the valves when the step cover is fully retracted.