

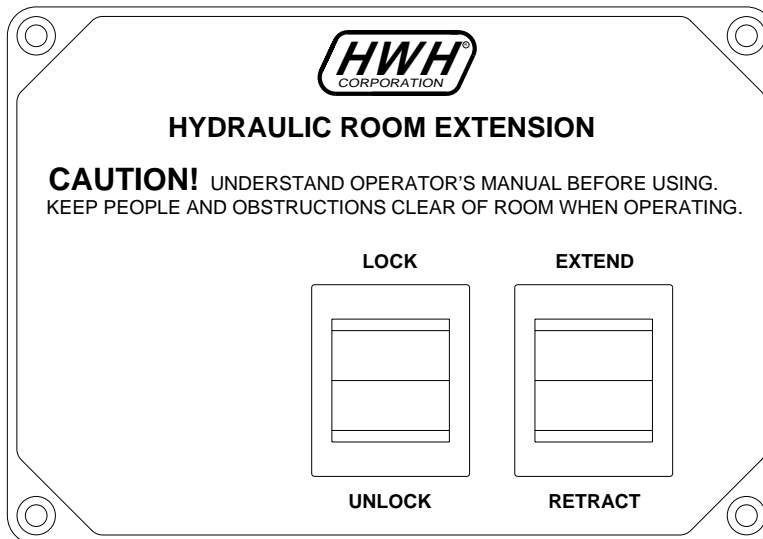

MANUAL TRAVEL CLAMPS WITH HWH ROOM EXTENSIONS

FEATURING:

*Two Rocker Switch Control Panel
225 Series Joystick Leveling System*



HWH CORPORATION

(On I-80, Exit 267 South)

2096 Moscow Road | Moscow, Iowa 52760

Ph: 800/321-3494 (or) 563/724-3396 | Fax: 563/724-3408

www.hwh.com

ELECTRICAL CONNECTION DIAGRAM

ROOM EXTENSION CONTROL WITH TRAVEL CLAMPS

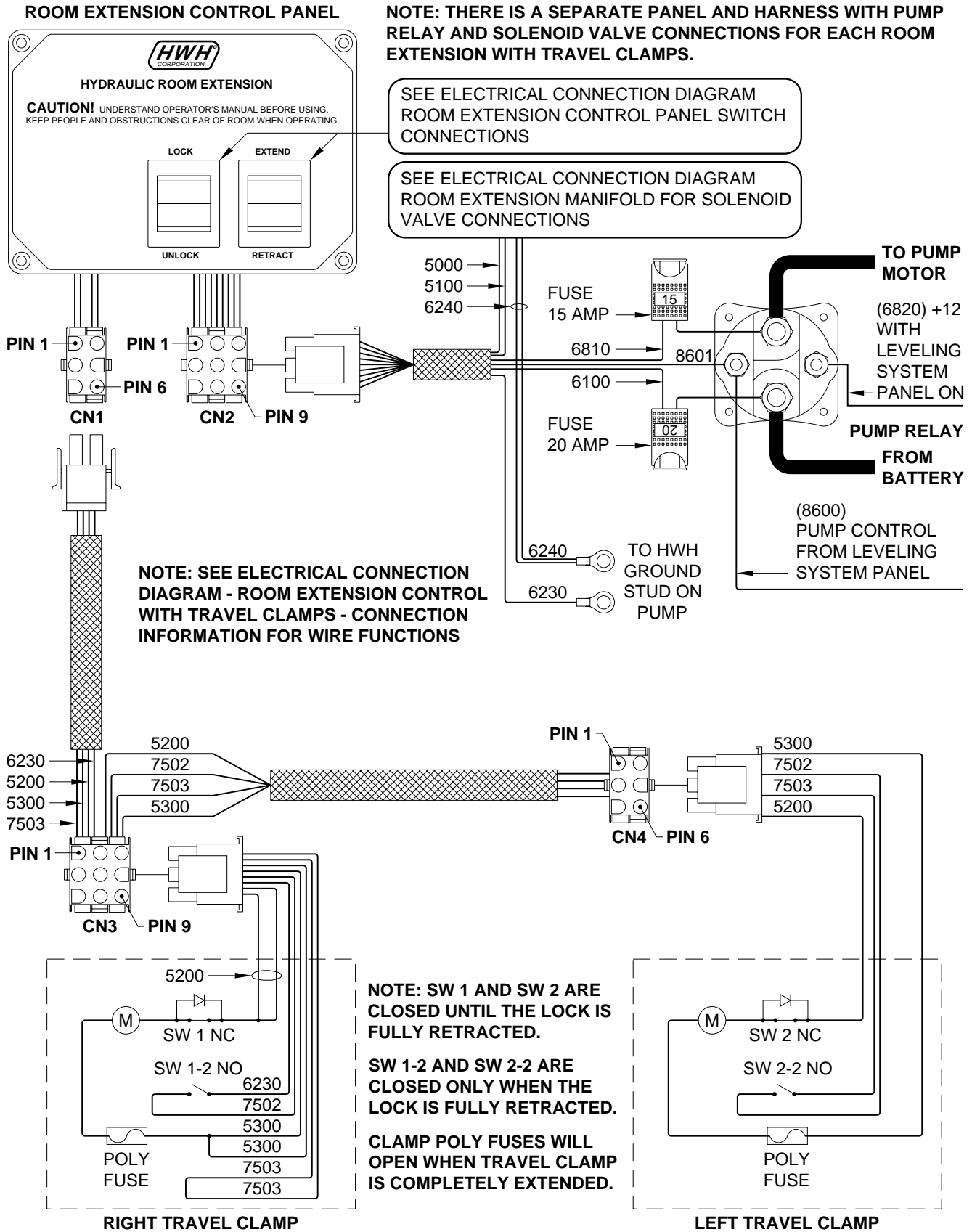

ELECTRICAL CONNECTION DIAGRAM

ROOM EXTENSION CONTROL WITH TRAVEL CLAMPS

CONNECTION INFORMATION

CN1 - 6 PIN UML CONNECTOR

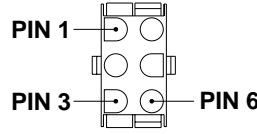

PIN #	WIRE COLOR	WIRE NUMBER	WIRE DESCRIPTION AND FUNCTION
1	WHITE	6230	GROUND TO RIGHT CLAMP SWITCH 1-2
2	BLACK	5300	CLAMP MOTOR SUPPLY - UNLOCK (GROUND) - LOCK (+12)
3	BLACK	5200	CLAMP MOTOR SUPPLY - UNLOCK (+12) - LOCK (GROUND)
4	BLACK	7503	GROUND TO ROOM CONTROL SWITCH - PUMP CONTROL
5 AND 6			NO CONNECTION

CN2 - 9 PIN UML CONNECTOR

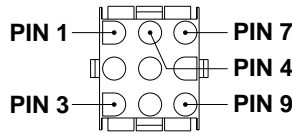

PIN #	WIRE COLOR	WIRE NUMBER	WIRE DESCRIPTION AND FUNCTION
1 AND 2	WHITE	6230	GRND TO ROOM CLAMP CONTROL SWITCH AND TO ROOM CLAMP SWITCH 1-2
3 AND 4	RED	6100	+12 BATTERY TO ROOM CLAMP CONTROL SWITCH
5	BLACK	5000	SWITCHED +12 FOR ROOM CYL EXTEND SOLENOID VALVE
6	BLACK	5100	SWITCHED +12 FOR ROOM CYL RETRACT SOLENOID VALVE
7	BLACK	8601	SWITCHED GRND FOR PUMP CONTROL FROM ROOM CONTROL SWITCH
8 AND 9	RED	6810	SWITCHED +12 FROM PUMP RELAY TO ROOM CONTROL SWITCH

CN3 - 9 PIN UML CONNECTOR

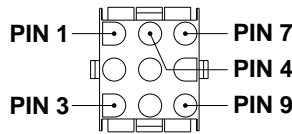

PIN #	WIRE COLOR	WIRE NUMBER	WIRE DESCRIPTION AND FUNCTION
1	BLACK	5200	RIGHT CLAMP MOTOR SUPPLY - UNLOCK (+12) - LOCK (GROUND)
2	WHITE	6230	GROUND TO RIGHT CLAMP SWITCH 1-2
3	BLACK	7502	SWITCHED GRND FROM RIGHT CLAMP SW 1-2 TO LEFT CLAMP SWITCH 2-2
4	BLACK	7503	SWITCHED GRND FROM LEFT CLAMP SWITCH 2-2 TO ROOM CONTROL SWITCH
5	BLACK	5300	RIGHT CLAMP MOTOR SUPPLY - UNLOCK (GROUND) - LOCK (+12)
6	BLACK	5300	TO LEFT CLAMP MOTOR SUPPLY - UNLOCKED (GROUND) - LOCK (+12)
7	BLACK	7503	SWITCHED GROUND FROM LEFT CLAMP SWITCH 2-2
8	BLACK	5200	TO LEFT CLAMP MOTOR SUPPLY - UNLOCK (+12) - LOCK (GROUND)
9			NO CONNECTION

CN4 - 6 PIN UML CONNECTOR

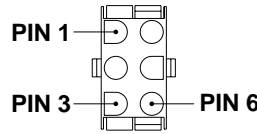

PIN #	WIRE COLOR	WIRE NUMBER	WIRE DESCRIPTION AND FUNCTION
1	BLACK	5200	LEFT CLAMP MOTOR SUPPLY - UNLOCK (+12) - LOCK (GROUND)
2	BLACK	7502	SWITCHED GRND FROM RIGHT CLAMP SW 1-2 TO LEFT CLAMP SW 2-2
3	BLACK	7503	SWITCHED GRND FROM LEFT CLAMP SWITCH 2-2 TO ROOM CONTROL SWITCH
4	BLACK	5300	LEFT CLAMP MOTOR SUPPLY - UNLOCK (GROUND) - LOCK (+12)
5 AND 6			NO CONNECTION

ELECTRICAL CONNECTION DIAGRAM ROOM EXTENSION CONTROL PANEL SWITCH CONNECTIONS

(REVERSE) ROOM EXTENSION CONTROL PANEL

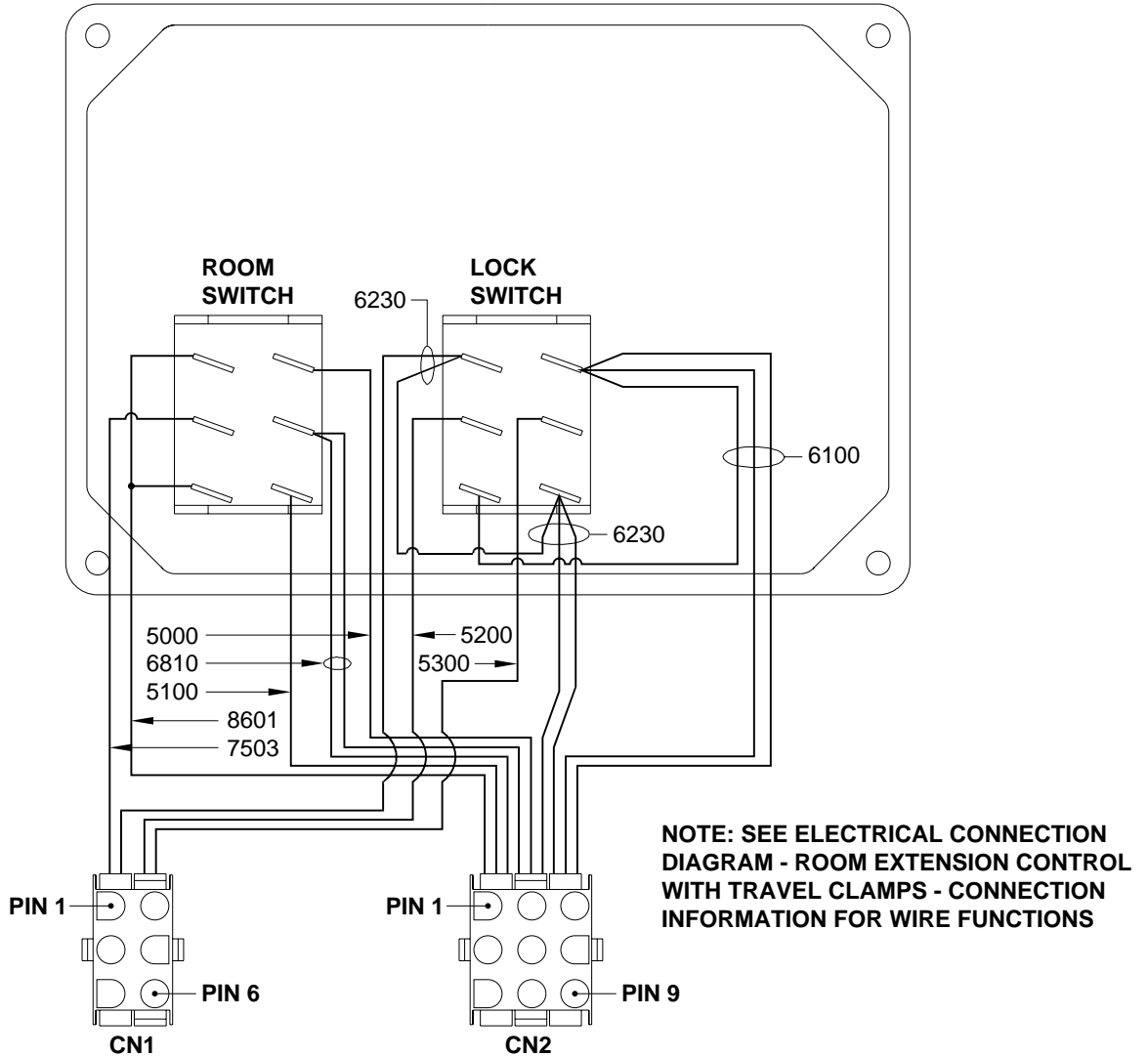

TRAVEL CLAMP SWITCH CONNECTIONS

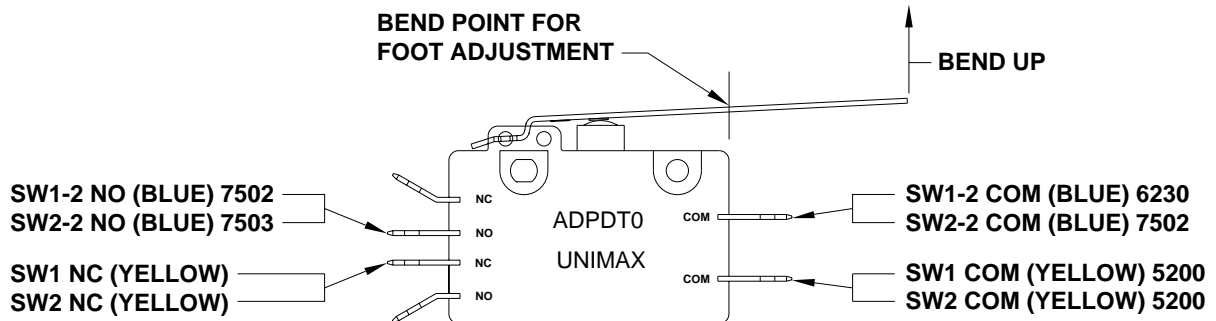

ROOM RETRACTED
CLAMP EXTENDED (ROOM CLAMPED)
210 LEVELING SYSTEM PANEL ON

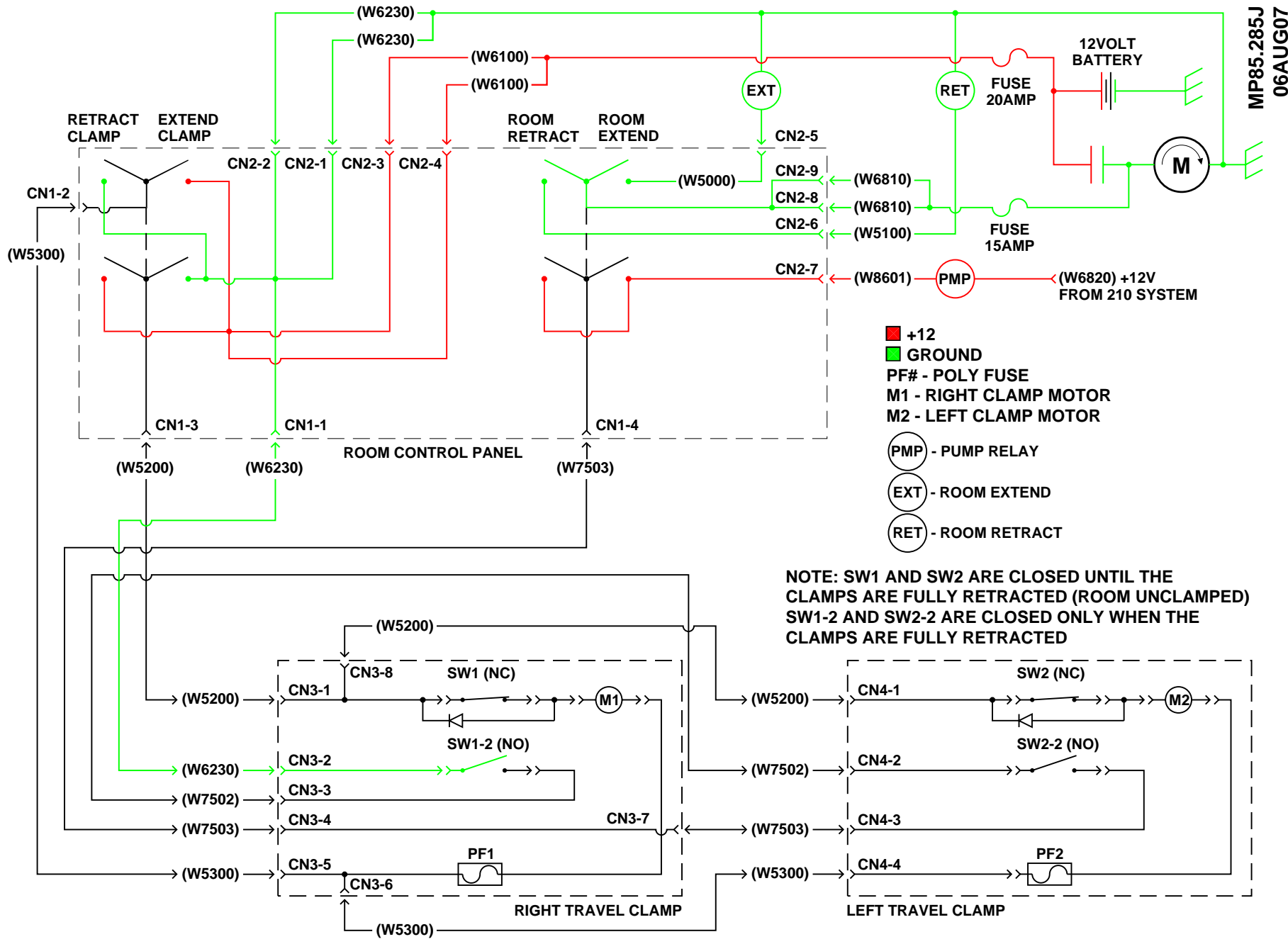

MP85.285J
06AUG07

ROOM RETRACTED
 CLAMP SWITCH PUSHED TO RETRACT CLAMP
 CLAMP RETRACTING (UNCLAMP ROOM)

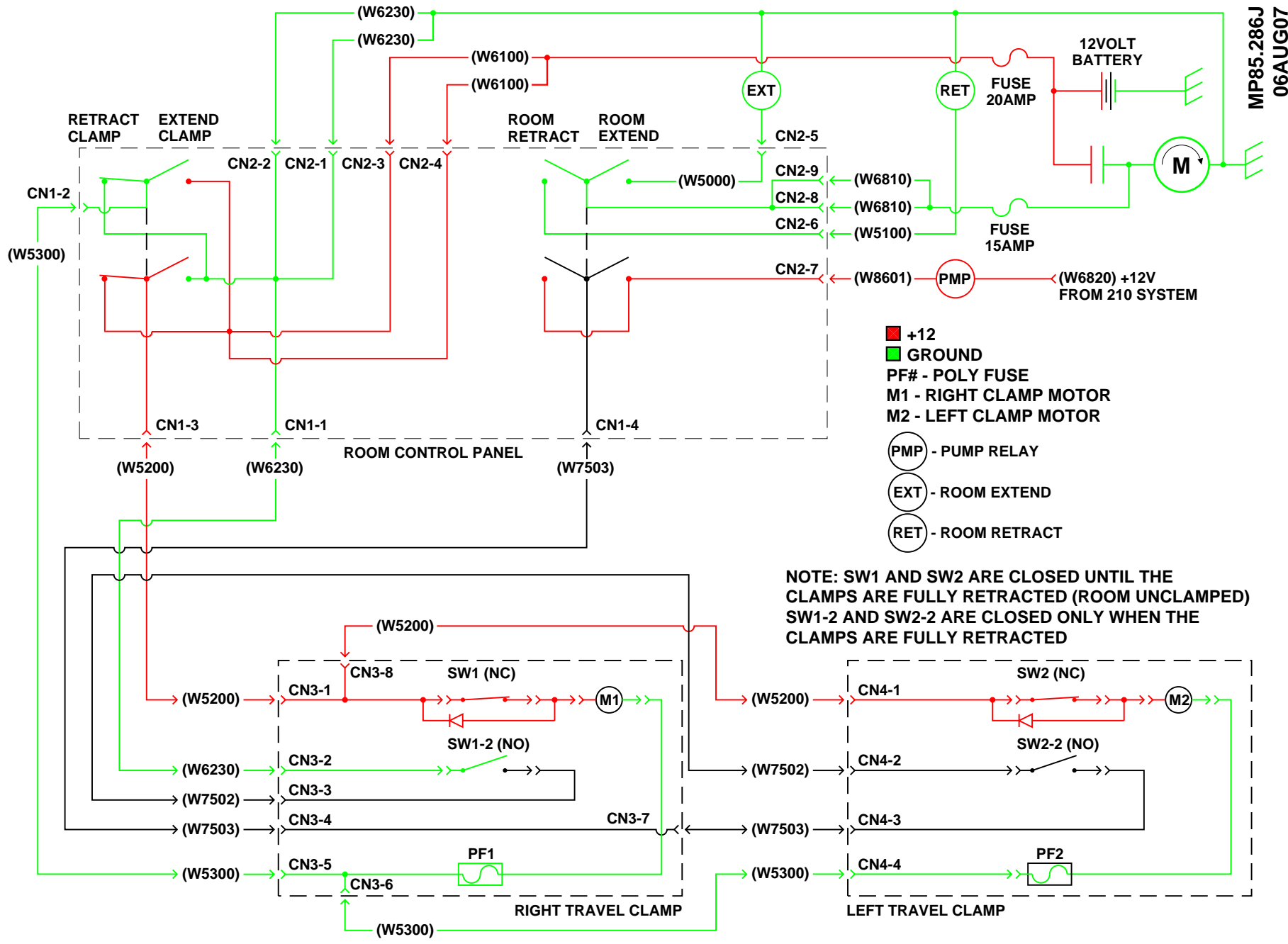

MP85.286J
06AUG07

ROOM RETRACTED
 ROOM CONTROL SWITCH PUSHED TO EXTEND
 ROOM EXTENDS

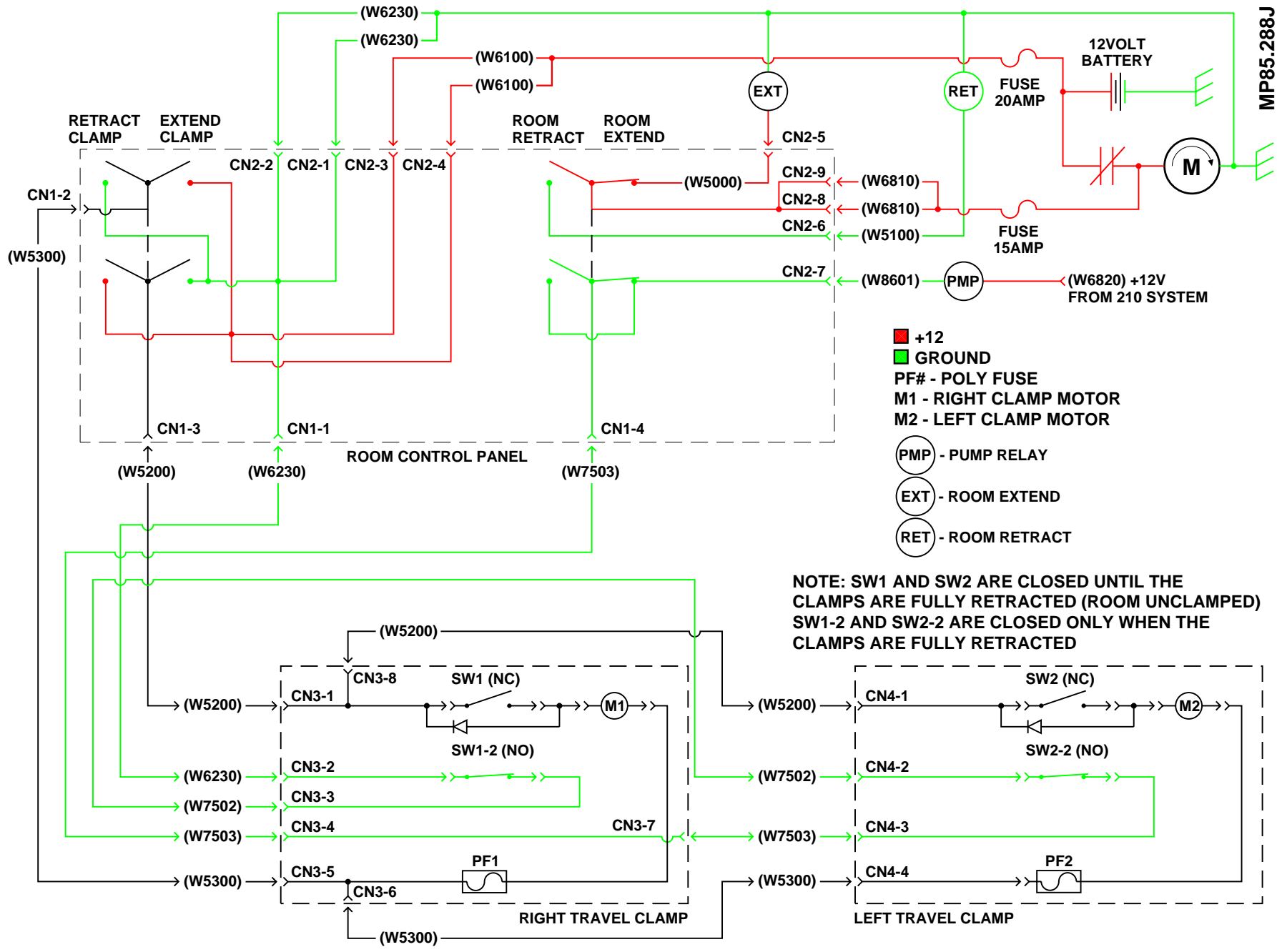

NOTE: SW1 AND SW2 ARE CLOSED UNTIL THE CLAMPS ARE FULLY RETRACTED (ROOM UNCLAMPED)
 SW1-2 AND SW2-2 ARE CLOSED ONLY WHEN THE CLAMPS ARE FULLY RETRACTED

MP85.288J
 06AUG07

ROOM EXTENDED
 ROOM CONTROL SWITCH PUSHED TO RETRACT
 ROOM RETRACTING

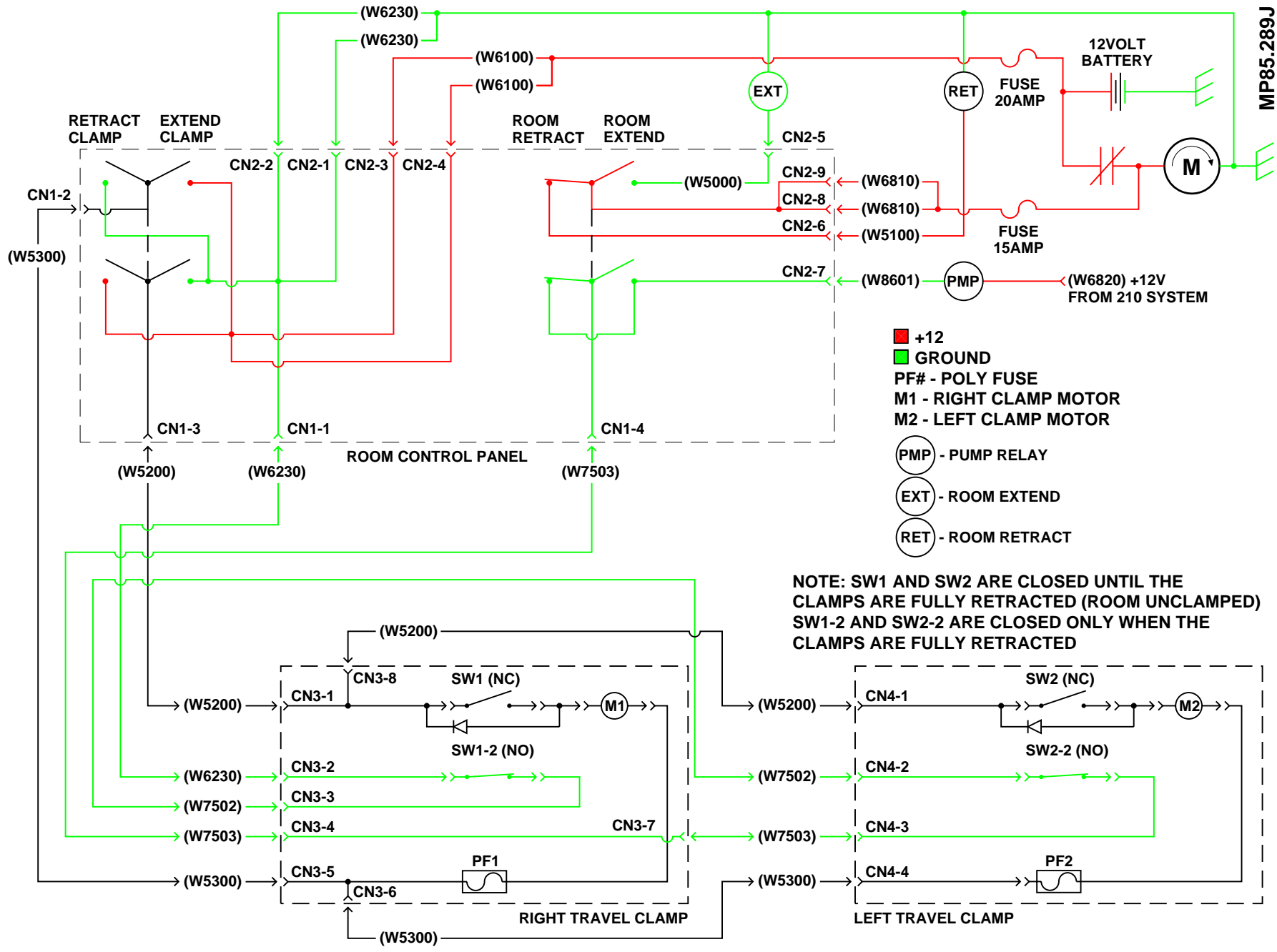

MP85.289J
06AUG07

ROOM RETRACTED
CLAMP SWITCH PUSHED TO EXTEND CLAMP
CLAMP EXTENDING (CLAMP ROOM)

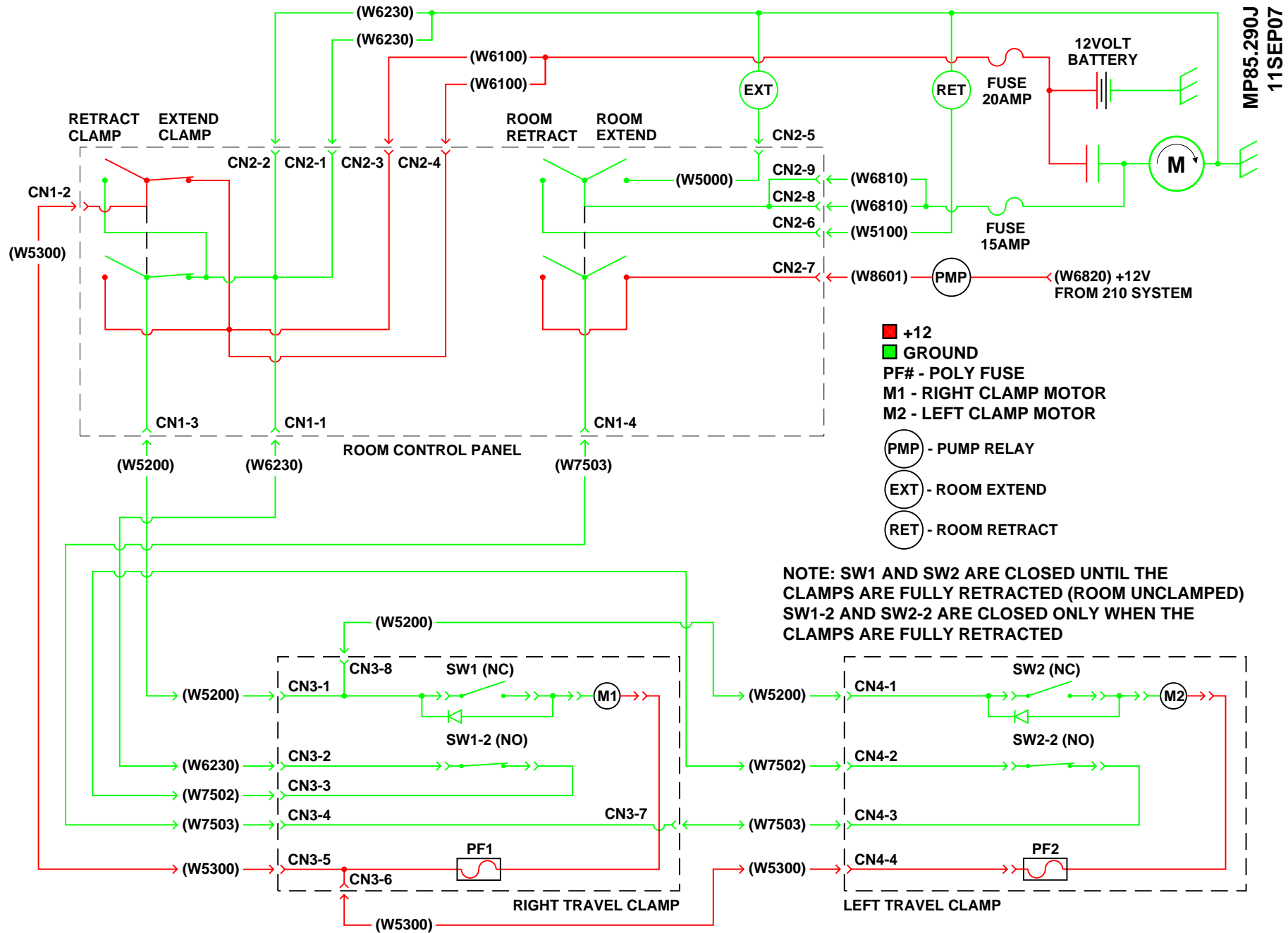

ROOM RETRACTED
CLAMP SWITCH PUSHED TO EXTEND CLAMP
CLAMP EXTENDING (CLAMP ROOM)

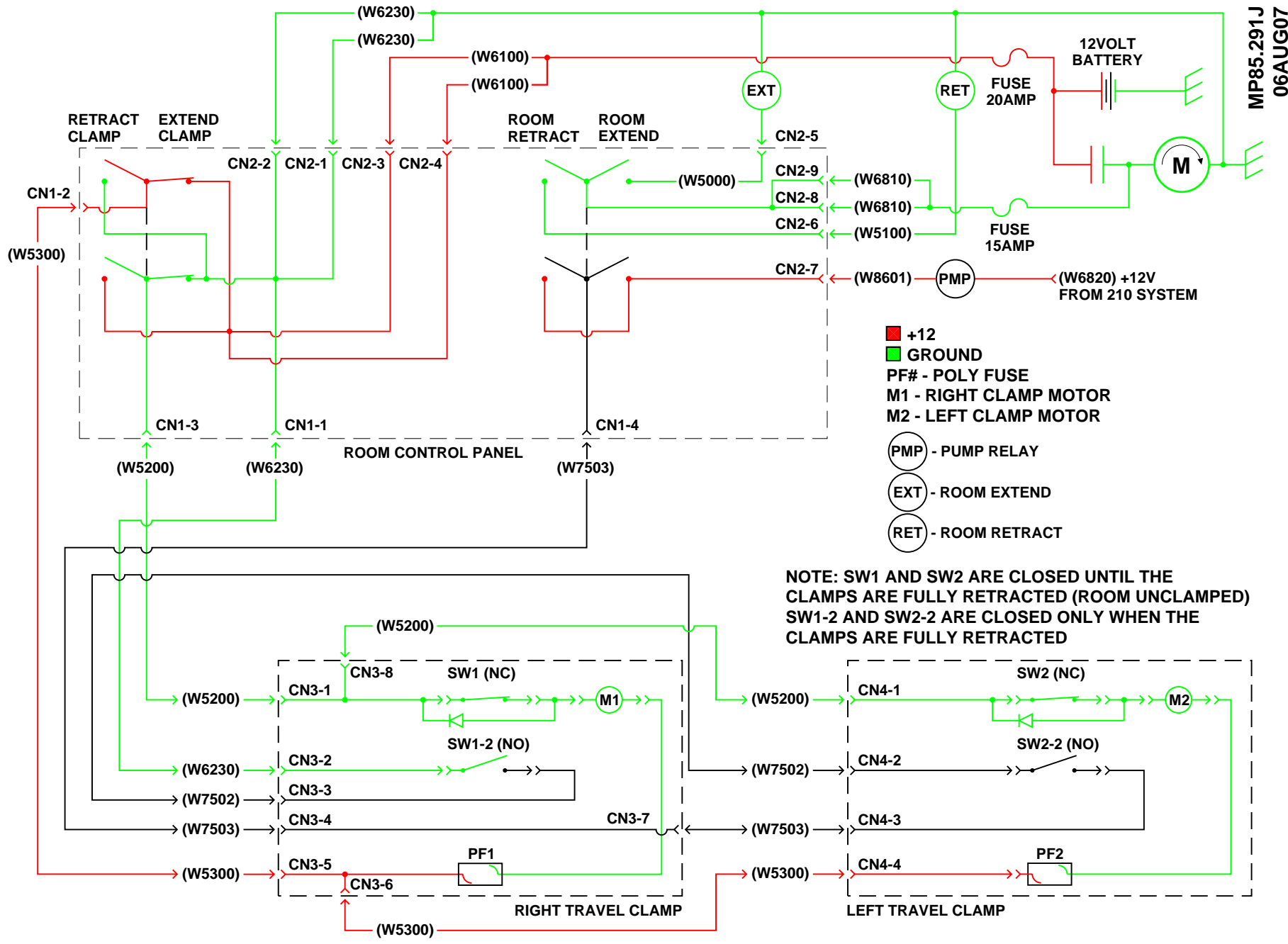

MP85.291J
06AUG07