



# OPERATOR'S MANUAL

## HWH® COMPUTER-CONTROLLED 625 SERIES LEVELING SYSTEM AND SPACEMAKER® ROOM EXTENSION SYSTEMS FOR TRAILERS

### FEATURING:

*Touch Panel Leveling Control  
BI-AXIS® Hydraulic Leveling  
Straight-Acting Jacks  
Multiple Room Extensions  
No Jack Stop Rods*

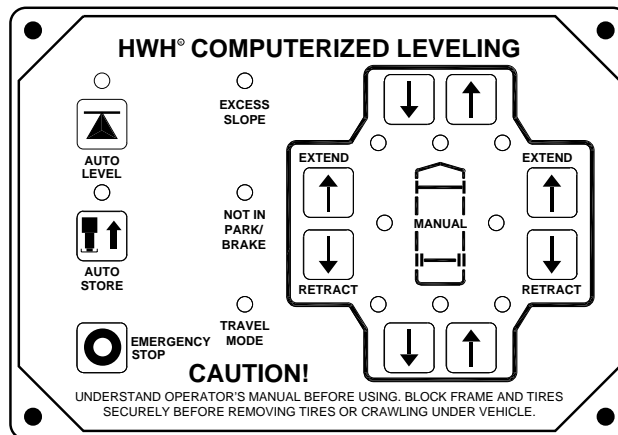

**HWH CORPORATION**  
(On I-80, Exit 267 South)  
2096 Moscow Road | Moscow, Iowa 52760  
Ph: 800/321-3494 (or) 563/724-3396 | Fax: 563/724-3408  
[www.hwh.com](http://www.hwh.com)

---

# OPERATOR'S MANUAL

---

## CAUTION !

**READ THE ENTIRE OPERATOR'S MANUAL BEFORE OPERATING.**

**BLOCK FRAME AND TIRES SECURELY BEFORE CRAWLING UNDER VEHICLE. DO NOT USE LEVELING JACKS OR AIR SUSPENSION TO SUPPORT VEHICLE WHILE UNDER VEHICLE OR CHANGING TIRES. VEHICLE MAY DROP AND/OR MOVE FORWARD OR BACKWARD WITHOUT WARNING CAUSING INJURY OR DEATH.**

**KEEP ALL PEOPLE CLEAR OF VEHICLE WHILE LEVELING SYSTEM IS IN USE.**

**WHILE HITCHING OR UNHITCHING, AVOID AREAS WHERE BODY MAY BE CRUSHED BY SUDDEN DROPPING OR SLIDING OF THE TRAILER.**

**DO NOT LIFT TOW VEHICLE WITH LEVELING SYSTEM.**

**NEVER PLACE HANDS OR OTHER PARTS OF THE BODY NEAR HYDRAULIC LEAKS. OIL MAY PENETRATE SKIN CAUSING INJURY OR DEATH.**

**WEAR SAFETY GLASSES WHEN INSPECTING OR SERVICING THE SYSTEM TO PROTECT EYES FROM DIRT, METAL CHIPS, OIL LEAKS, ETC. FOLLOW ALL OTHER APPLICABLE SHOP SAFETY PRACTICES.**

**IMPORTANT: IF VEHICLE IS EQUIPPED WITH A ROOM EXTENSION, READ ROOM EXTENSION SECTION BEFORE OPERATING LEVELING SYSTEM.**

## HOW TO OBTAIN WARRANTY SERVICE

### THIS IS NOT TO BE INTERPRETED AS A STATEMENT OF WARRANTY

HWH CORPORATION strives to maintain the highest level of customer satisfaction. Therefore, if you discover a defect or problem, please do the following:

**FIRST:** Notify the dealership where you purchased the vehicle or had the leveling system installed. Dealership management people are in the best position to resolve the problem quickly. If the dealer has difficulty solving the problem, he should immediately contact the Customer Service Department, at HWH CORPORATION.

**SECOND:** If your dealer cannot or will not solve the problem, notify the Customer Service Department:  
HWH CORPORATION 2096 Moscow Rd. Moscow IA. 52760  
(563) 724-3396 OR (800) 321-3494. Give your name and address, coach manufacturer and model year, date the coach was purchased, or the date of system installation,

description of the problem, and where you can be reached during business hours (8:00 a.m. till 5:00 p.m. c.s.t.). HWH CORPORATION personnel will contact you to determine whether or not your claim is valid. If it is, HWH CORPORATION will authorize repair or replacement of the defective part, either by appointment at the factory or by the authorization of an independent service facility, to be determined by HWH CORPORATION. All warranty repairs must be performed by an independent service facility authorized by HWH CORPORATION, or at the HWH CORPORATION factory, unless prior written approval has been obtained from proper HWH CORPORATION personnel.

# CONTROL IDENTIFICATION

## 625 SERIES LEVELING SYSTEM

### COMPUTER-CONTROL

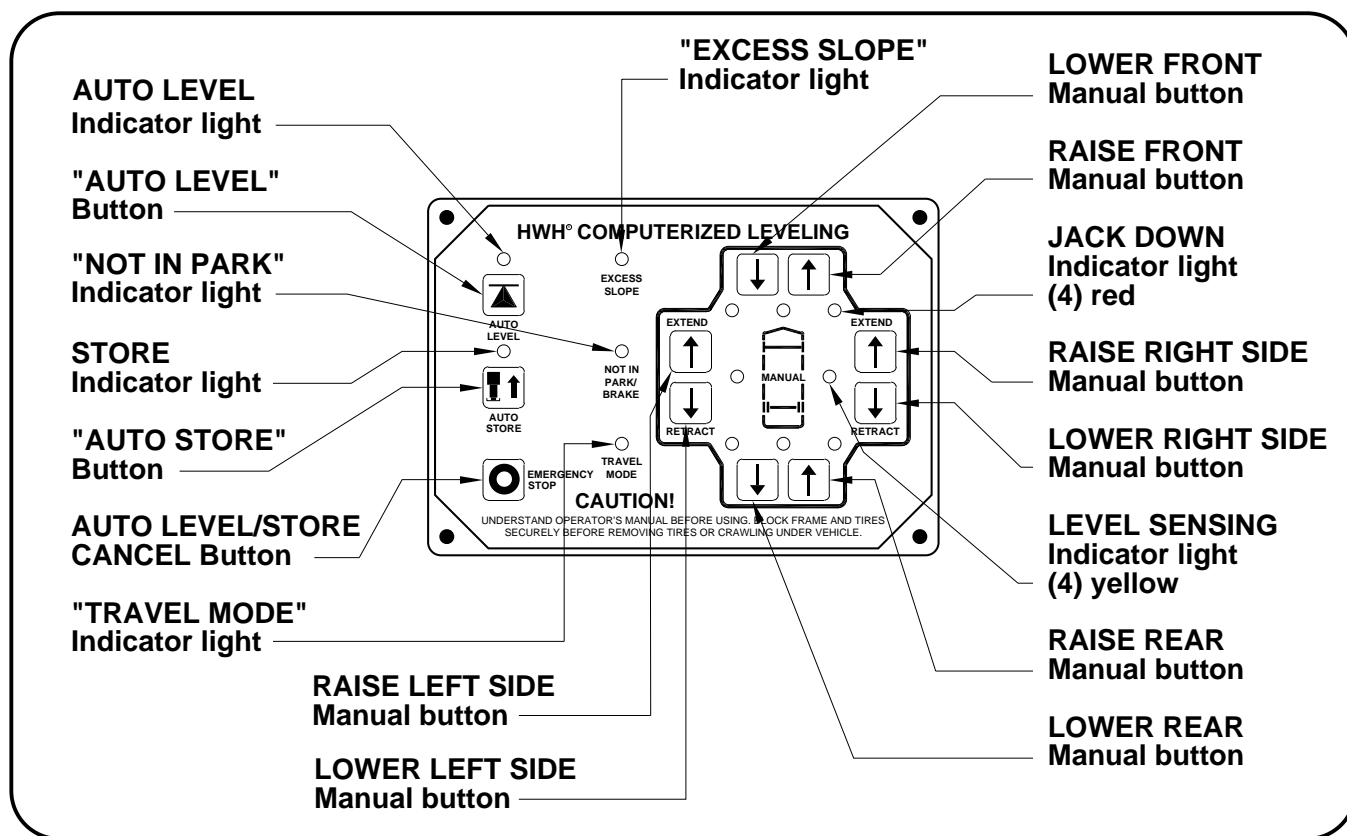

## CONTROL FUNCTIONS

### CONTROL BUTTONS

**"EMERGENCY STOP" BUTTON:** Push this button to stop any leveling system operation.

**"AUTO LEVEL" BUTTON:** Push this button any time to start the automatic leveling function.

**"AUTO STORE" BUTTON:** Push this button to retract all four jacks at the same time.

**EXTEND BUTTONS (UP ARROWS):** These buttons will extend their respective jack pairs to lift the vehicle.

**RETRACT BUTTONS (DOWN ARROWS):** These buttons will retract their respective jack pairs to lower the vehicle.

### INDICATOR LIGHTS

**AUTO LEVEL INDICATOR LIGHT:** This light will flash during the automatic leveling function.

**STORE INDICATOR LIGHT:** This light will flash during the automatic store function.

### INDICATOR LIGHTS (CONTINUED)

**LEVELING LIGHTS:** The four yellow indicating lights are level sensing indicators. When a yellow light is on, it indicates that its side, end, or corner of the vehicle is low. No more than two lights should be on at the same time. When all four yellow LEVEL lights are out, the vehicle is level.

**WARNING LIGHTS:** The four red lights surrounding the yellow level indicators are jacks down WARNING lights. They are functional whenever the jacks are extended 1/4 to 1/2 inch.

**"EXCESS SLOPE" LIGHT:** This indicator will light when the leveling system cannot level the vehicle.

**"NOT IN PARK/BRAKE" LIGHT:** Not Applicable.

**"TRAVEL MODE" LIGHT:** This indicator light will be on when the jacks are retracted and there are no red WARNING lights on.

## CONTROL IDENTIFICATION

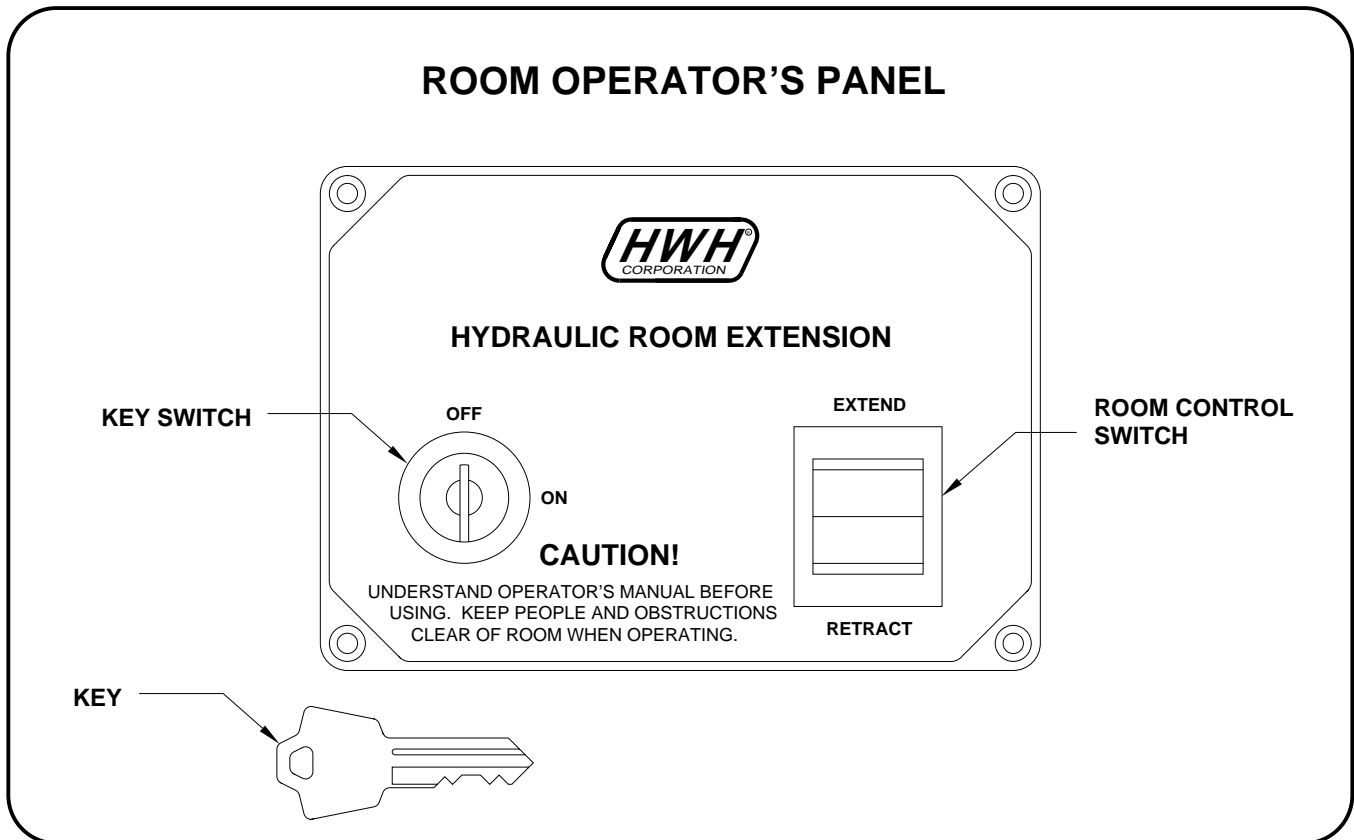

## CONTROL FUNCTIONS

**KEY SWITCH:** The KEY SWITCH controls power to the ROOM CONTROL SWITCH. When the KEY SWITCH is in the "ON" POSITION the room can be operated, and the key cannot be removed. When the KEY SWITCH is in the "OFF" position the room cannot be operated, and the key can be removed.

**ROOM CONTROL SWITCH:** The ROOM CONTROL SWITCH is a two position momentary switch. Pressing the switch in the EXTEND POSITION will extend the room. Pressing the switch in the RETRACT POSITION will retract the room. Releasing the ROOM CONTROL SWITCH will halt the operation of the room.

## OEM PROVIDED ROOM SELECTOR SWITCH (IF APPLICABLE)

**ROOM SELECTOR SWITCH:** This switch (not shown) is OEM provided. Refer to OEM operator instructions.

---

# OPERATING PROCEDURES

---

## GENERAL INSTRUCTIONS

Maintain adequate clearance in all directions for vehicle, room extensions, awnings, doors, steps, etc. Vehicle may move in any direction due to jacks extending or retracting, settling of the jacks or the vehicle, equipment malfunction, etc..

If parking on soft ground or asphalt paving, wood blocks or pads must be placed under the jacks.

Press the "EMERGENCY STOP" button at any time to stop the operation of the system.

Any time a hydraulic leveling process is interrupted, retract the jacks according to the JACK RETRACTION Section and then restart the leveling process.

**CAUTION: DO NOT MOVE THE VEHICLE IF ONE OR MORE JACKS ARE EXTENDED TO THE GROUND.**

## PREPARATION FOR TRAVEL

Before traveling, the red jack warning lights must be off and the "TRAVEL MODE" light must be on. If lights are not correct for travel, retract jack as described in the JACK RETRACTION Section.

If the jacks are retracted but a red "WARNING" light is lit or the green "TRAVEL MODE" light is not lit, the system needs to be serviced.

Any room extension should be fully retracted before traveling.

**CAUTION: DO NOT MOVE THE VEHICLE WHILE THE LEVELING JACKS ARE STILL IN CONTACT WITH THE GROUND OR IN THE EXTEND POSITION. THIS**

**VEHICLE IS EQUIPPED WITH STRAIGHT-ACTING JACKS. MOVING THE VEHICLE WITH THE LEVELING JACKS EXTENDED CAN CAUSE SEVERE DAMAGE TO THE JACKS AND OR THE VEHICLE AND CREATE A DRIVING HAZARD. DO NOT RELY SOLELY UPON WARNING LIGHTS. IT IS THE OPERATOR'S RESPONSIBILITY TO CHECK THAT ALL JACKS ARE FULLY RETRACTED INTO THE STORE/TRAVEL POSITION.**

Any time the "AUTO LEVEL" button has been pushed, push the "AUTO STORE" button before traveling.

If the jacks cannot be retracted according to the JACK RETRACTION Section, retract the jacks according to the MANUAL JACK RETRACTION Section. The system should then be checked.

## ROOM EXTENSION PROCEDURES

**IMPORTANT: If the vehicle is equipped with a room extension read this section carefully.**

**IMPORTANT: It is recommended to level and stabilize the vehicle before extending the room.**

**IMPORTANT: Extending or retracting any leveling jacks when the room is extended is not recommended.**

Refer to the vehicle owner's manual for proper operation of room extensions.

**IMPORTANT: Do not use a room extension support when the vehicle is supported by the leveling system.**

---

# OPERATING PROCEDURES

---

## SET UP AND AUTOMATIC LEVELING PROCEDURE

1. Trailer must be unhitched from the tow vehicle before leveling. The HWH front jacks may be used to lift the trailer for unhitching. If auxiliary jacks are used to unhitch the trailer, extend the HWH front jacks to the ground and retract the auxiliary jacks before the leveling system is used for leveling.

**NOTE: The manual buttons (UP and DOWN arrows) on the right side of the panel will function at any time. The front UP arrow (Raise Front) manual button will extend the front jacks. DO NOT push the "AUTO LEVEL" button if the manual buttons are to be used.**

**NOTE: Refer to the trailer manufacturer owner's manual for unhitching.**

If parking on soft ground or asphalt paving, a wood block or pad should be placed under each jack.

**IMPORTANT: Overheating and excessive current drain will result if raise arrows are operated for an extended period of time.**

2. Lower the front of the trailer until the front yellow level indicator light comes on. This is done by pushing the front RETRACT button (DOWN ARROW). The red jacks down warning lights will light when the jacks are extended 1/4 to 1/2 inch.

**NOTE: The front yellow LEVEL light must be on before automatic leveling will function.**

3. Press the "AUTO LEVEL" button. The "AUTO LEVEL" light will start to flash.

The system will automatically extend the jacks to level the vehicle and then extend any remaining jacks for stabilizing. After the system has finished leveling and stabilizing, it will automatically shut off.

**EXCESS SLOPE SITUATION:** In the event the jacks are unable to level the coach, the "EXCESS SLOPE" light will come on. Excess slope is two jacks fully extended without turning the yellow level light out. The system will not stabilize the vehicle if the "EXCESS SLOPE" light comes on. One or more jacks may be extended. The system will shut off leaving the "EXCESS SLOPE" light on. The "EXCESS SLOPE" light will remain on if there is power to the control box, until the jacks have been fully retracted turning the red warning lights out. Refer to the JACK RETRACTION section. Move the vehicle to a more level position or level the vehicle as close as possible according to the MANUAL LEVELING section.

---

# OPERATING PROCEDURES

---

## PREPARATION FOR TRAVEL

**CAUTION:** THE OPERATOR MUST BE SURE THAT THERE ARE NO OBJECTS UNDER THE VEHICLE AND THAT ALL PEOPLE ARE CLEAR OF THE VEHICLE.

1. Hitch the trailer to the tow vehicle using the procedure supplied by the trailer manufacturer. The front Retract (Down Arrow) button should be used to hitch the trailer to the tow vehicle.

**IMPORTANT:** DO NOT push the "AUTO STORE" button until the trailer is hitched to the tow vehicle. The "AUTO STORE" button will not function until there is no weight on the front jacks.

2. After the trailer is securely hitched to the tow vehicle, and the weight of the trailer is off of the front jacks, push the "AUTO STORE" button. All 4 jacks will retract. The panel will automatically turn off 6 minutes after the last of the four red warning lights go out. If any red warning light remains on, the system will try to store the jacks for 20 minutes from the time the "AUTO STORE" button is pushed, then turn off.

**NOTE:** If any one of the four red WARNING lights do not go out, the system will not shut off. Push the "EMERGENCY STOP" button to turn the system off.

**NOTE:** Pushing a room control switch to extend or retract will interrupt the STORE mode. When the switch is released, the leveling system will return to the STORE mode.

**CAUTION:** ONLY USE THE "AUTO STORE" BUTTON IF THE TRAILER IS HITCHED TO A TOW VEHICLE OR SECURELY SUPPORTED BY THE EXISTING LANDING GEAR.

**IMPORTANT:** DO NOT interrupt power to the leveling system while the AUTO STORE indicator light is on. DO NOT push the "EMERGENCY STOP" button. The system must be allowed to completely finish the STORE mode.

**CAUTION:** DO NOT MOVE THE VEHICLE WHILE THE LEVELING JACKS ARE STILL IN CONTACT WITH THE GROUND OR IN THE EXTEND POSITION. THIS VEHICLE IS EQUIPPED WITH STRAIGHT ACTING JACKS. MOVING THE VEHICLE WITH THE LEVELING JACKS EXTENDED CAN CAUSE SEVERE DAMAGE TO THE JACKS AND OR THE VEHICLE AND CREATE A DRIVING HAZARD. DO NOT RELY SOLELY UPON WARNING LIGHTS. IT IS THE OPERATOR'S RESPONSIBILITY TO CHECK THAT ALL JACKS ARE FULLY RETRACTED INTO THE STORE/TRAVEL POSITION.

3. If jacks cannot be retracted by the above procedure see MANUAL JACK RETRACTION Section.

---

# OPERATING PROCEDURES

---

## MANUAL LEVELING

1. Trailer must be unhitched from the tow vehicle before leveling. The HWH front jacks may be used to lift the trailer for unhitching. If auxiliary jacks are used to unhitch the trailer, extend the HWH front jacks to the ground and retract the auxiliary jacks before the leveling system is used for leveling.

**NOTE: Refer to the trailer manufacturer owner's manual for unhitching.**

If parking on soft ground or asphalt paving, a wood block or pad should be placed under each jack.

**IMPORTANT: Overheating and excessive current drain will result if raise arrows are operated for an extended period of time.**

2. Lower the front of the trailer until the front yellow level indicator lights come on. This is done by pushing the front RETRACT button (DOWN ARROW). The red jacks down warning lights will light when the jacks are extended 1/4 to 1/2 inch.

3. A lit yellow LEVEL light indicates that the side, end or corner of the trailer is low. Pushing the up arrow for corresponding yellow level lights will extend that jack or jack pair to level the vehicle. Extend jacks as needed to put out all the yellow lights. Always give a side yellow level light priority when leveling the trailer. If the ground is too uneven, the jacks may not have enough stroke to level the trailer. The trailer may have to be moved.

**NOTE: When a side arrow (UP or DOWN) is pushed only the rear jack on that side will extend or retract.**

4. After the trailer is level, the jacks not used for leveling may be extended until they touch the ground. This provides additional stability against wind and activity in the trailer. Jacks used to stabilize the trailer should lift the trailer about 3/4 inch.

# OPERATING PROCEDURES MANUAL JACK RETRACTION FOR TRAILERS WITHOUT LOCK VALVE

## MANUAL JACK RETRACTION

**CAUTION:** KEEP AWAY FROM THE WHEELS, DO NOT CRAWL UNDER THE VEHICLE, KEEP A SAFE DISTANCE IN FRONT AND REAR OF THE VEHICLE. THE VEHICLE MAY DROP AND/OR MOVE FORWARD OR BACKWARD WITHOUT WARNING AS THE VALVE RELEASE IS OPERATED.

**IMPORTANT:** HWH recommends that all HWH room extensions are fully retracted prior to performing manual jack retraction procedures.

Use the manual valve release for retracting the jacks only if the STORE feature on the HWH control panel will not retract the jacks.

1. Locate your power unit-manifold assembly.  
(The diagram below represents a typical Power Unit-Manifold Assembly it may not be an exact match to yours).

**NOTE:** Multiple manifolds may be present on the power unit. The upper most manifold should control jack functions. (Valve styles and arrangements will vary)

2. Allow clearance for the vehicle to lower. If equipped with landing gear, lower the landing gear to support the trailer while manually retracting the jacks.

3. Using the diagrams below identify the style and location of your two front jack control valves.

**NOTE:** As of APRIL 2002 a 1/4" Nut Driver has been incorporated into the Breather Cap. Before using read and understand the last page of this manual.

**Small style with Valve Release Nut:** DO NOT turn the 1/4" valve release nut more than 4 and 1/2 turns. Turning the nut more could damage the valve.

**Large style with T-Handle valve release:** The T-Handle will turn several turns easily. As the valve starts to open, the T-Handle will turn harder. Make sure the valves have been opened far enough to allow the jacks to retract.

**Large style with Valve Release Nut:** The 1/4" Valve release nut is located under a plastic plug that must be removed to gain access. DO NOT turn the 1/4" valve release nut more than 1 full turn. Turning the nut more could damage the valve.

4. Retract the front jacks by opening the correct valves. Slowly turn the manual valve releases counter clockwise until the jacks start to retract. Hitch the trailer to the tow vehicle during this operation if the vehicle is not equipped with an alternate landing gear.

5. Repeat the process by identifying then opening the two rear control valves.

6. Check that all jacks are now retracted. If yes, continue. If no, notify the dealership where you purchased the vehicle or had the leveling system installed or contact HWH Corporation customer service.

7. Close the valves by turning each valve release clockwise.

**IMPORTANT:** Once the manual valve release is snug, DO NOT tighten the manual valve release past this point as internal damage may occur to the solenoid.

8. Retract all landing gear before traveling.

9. The system should now be repaired before using again.

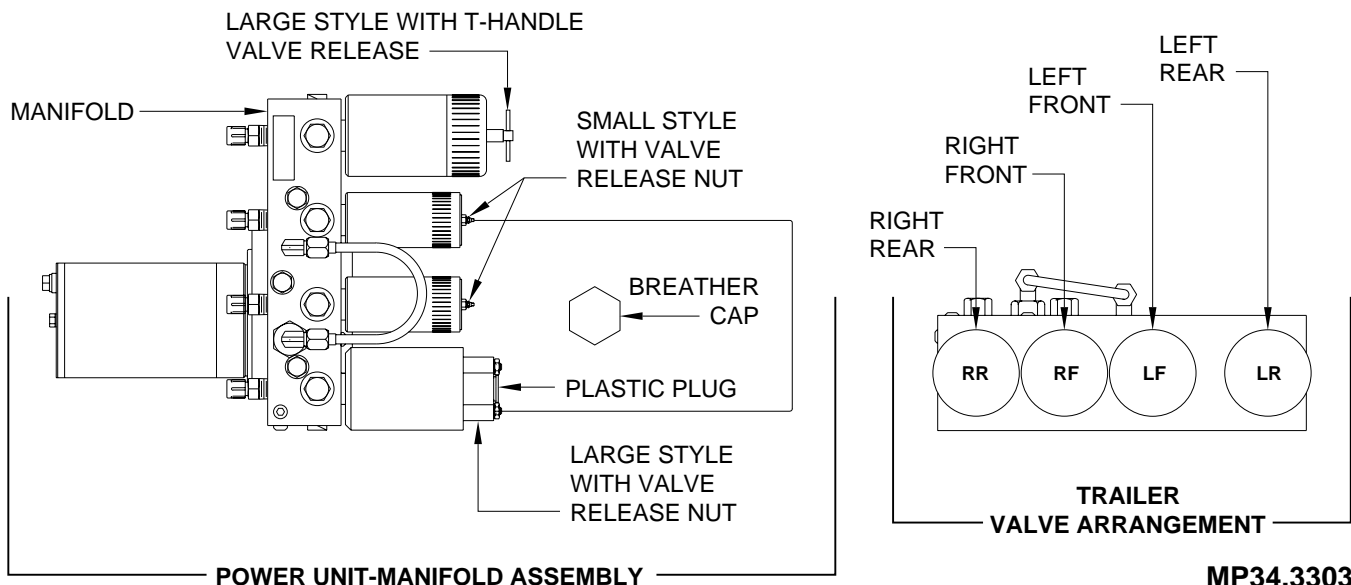

# OPERATING PROCEDURES MANUAL JACK RETRACTION FOR TRAILERS WITH LOCK VALVE

## MANUAL JACK RETRACTION

**CAUTION:** KEEP AWAY FROM THE WHEELS, DO NOT CRAWL UNDER THE VEHICLE, KEEP A SAFE DISTANCE IN FRONT AND REAR OF THE VEHICLE. THE VEHICLE MAY DROP AND/OR MOVE FORWARD OR BACKWARD WITHOUT WARNING AS THE VALVE RELEASE IS OPERATED.

**IMPORTANT:** HWH recommends that all HWH room extensions are fully retracted prior to performing manual jack retraction procedures.

Use the manual valve release for retracting the jacks only if the STORE feature on the HWH control panel will not retract the jacks.

1. Locate your power unit-manifold assembly. (The diagram below represents a typical Power Unit-Manifold Assembly it may not be an exact match to yours).

**NOTE:** Multiple manifolds may be present on the power unit. The upper most manifold should control jack functions. (Valve styles and arrangements will vary)

2. Allow clearance for the vehicle to lower. If equipped with landing gear, lower the landing gear to support the trailer while manually retracting the jacks.

3. Using the diagrams below identify the style and location of your two rear jack control valves.

**NOTE:** As of APRIL 2002 a 1/4" Nut Driver has been incorporated into the Breather Cap. Before using read and understand the last page of this manual.

**Small style with Valve Release Nut:** DO NOT turn the 1/4" valve release nut more than 4 and 1/2 turns. Turning the nut more could damage the valve.

**Large style with T-Handle valve release:** The T-Handle will turn several turns easily. As the valve starts to open, the T-Handle will turn harder. Make sure the valves have been opened far enough to allow the jacks to retract.

**Large style with Valve Release Nut:** The 1/4" Valve release nut is located under a plastic plug that must be removed to gain access. DO NOT turn the 1/4" valve release nut more than 1 full turn. Turning the nut more could damage the valve.

4. Retract the rear jacks by opening the correct valves. Slowly turn the manual valve releases counter clockwise until the jacks start to retract.

5. Repeat the process by identifying then opening the two front control valves. Hitch the trailer to the tow vehicle during this operation if the trailer is not equipped with an alternate landing gear.

6. Check that all jacks are now retracted. If yes, continue. If no, notify the dealership where you purchased the vehicle or had the leveling system installed or contact HWH Corporation customer service.

7. Close the valves by turning each valve release clockwise.

**IMPORTANT:** Once the manual valve release is snug, DO NOT tighten the manual valve release past this point as internal damage may occur to the solenoid.

8. Retract all landing gear before traveling.

9. The system should now be repaired before using again.

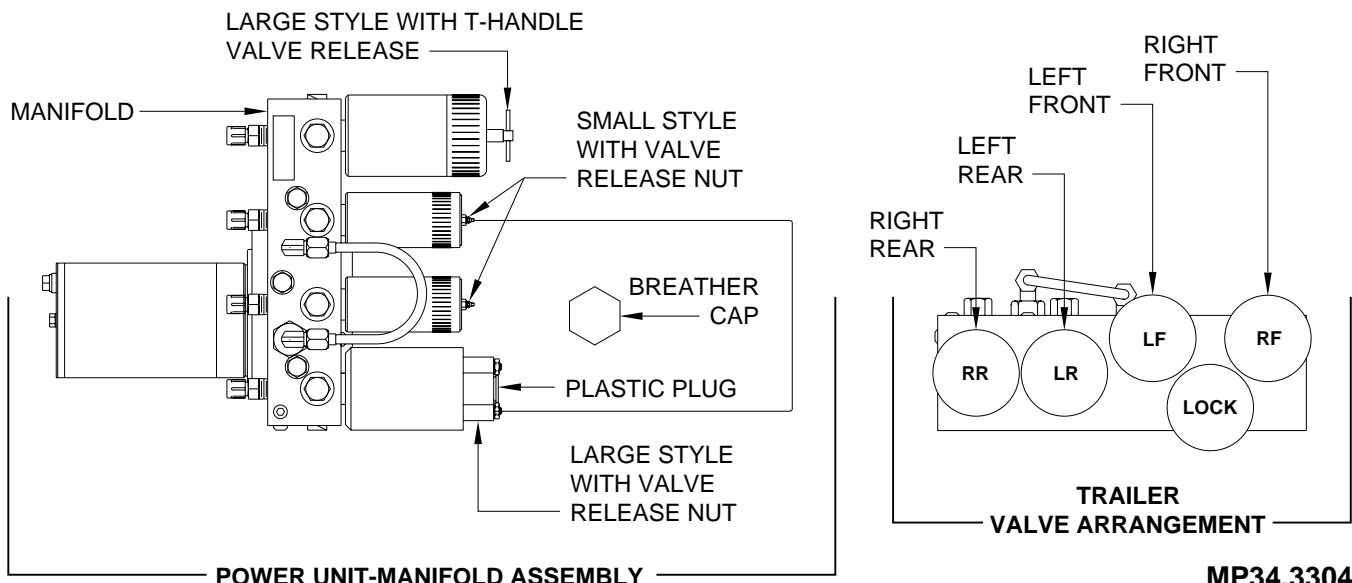

---

# OPERATING PROCEDURES

---

## ROOM EXTEND PROCEDURE FOR ROOMS WITHOUT TRAVEL CLAMPS

**WARNING:** OPERATING A ROOM WITH ANY ROOM LOCKING, CLAMPING OR MANUAL RETRACTING DEVICES ATTACHED OR ENGAGED CAN CAUSE PERSONAL INJURY AND VEHICLE DAMAGE. IT IS THE OPERATOR'S RESPONSIBILITY TO ENSURE THAT ALL ROOM LOCKING, CLAMPING OR MANUAL RETRACTING DEVICES ARE DETACHED OR DISENGAGED BEFORE OPERATING THE ROOM.

**NOTE:** It is recommended to complete any applicable Leveling Procedure before operating room extensions. It is recommended to retract room extensions before retracting a leveling system.

1. The park brake must be set for motorized vehicles. The room will not operate if the park brake is not set.
2. Follow applicable LEVELING AND STABILIZING PROCEDURES.
3. Unlock all room-locking devices to include travel clamps/locks supplied by manufacturers other than HWH.

**NOTE:** If the MANUAL RETRACT WINCH is attached to the room remove it before extending the room.

**WARNING:** KEEP PEOPLE AND OBSTRUCTIONS CLEAR OF ROOM WHEN OPERATING.

**NOTE:** Make sure there is adequate clearance to fully extend the room.

4. Turn the ignition switch to ACCESSORY or turn a MASTER POWER SWITCH on, if applicable.
5. Turn the room control panel KEY SWITCH to the "ON" position.

6. To extend the room, press and hold the ROOM CONTROL SWITCH in the "EXTEND" position until the room is fully extended.

**NOTE:** Hold the switch to "EXTEND" three or four seconds after the room is fully extended. This assures proper pressurization of the cylinders. **During normal operation of the room, do not reverse direction of the room until the room is fully extended. If necessary, the direction of the room may be reversed, but watch for binding of the room. If the direction of the room has been reversed, DO NOT re-extend the room until the room has been fully retracted.**

**IMPORTANT:** Do not hold the ROOM CONTROL SWITCH in the "EXTEND" position for more than ten seconds after the room is fully extended or stops moving. **If either side of the room stops moving, release the room control switch immediately. DO NOT force the room. DO NOT reverse direction of the room, contact HWH Customer Service for assistance 1-800-321-3494.**

**NOTE:** Releasing the ROOM CONTROL SWITCH will halt the operation of the room.

7. Turn the room control panel KEY SWITCH to the "OFF" position.
8. Turn off the ignition switch, if applicable.

**IMPORTANT:** Do not use a room extension support when the vehicle is supported by the leveling system.

---

# OPERATING PROCEDURES

---

## ROOM RETRACT PROCEDURE FOR ROOMS WITHOUT TRAVEL CLAMPS

**WARNING:** KEEP PEOPLE AND OBSTRUCTIONS CLEAR OF ROOM WHEN OPERATING.

**NOTE:** It is recommended to retract room extensions before retracting a leveling system.

1. The park brake must be set, if applicable. The room will not operate if the park brake is not set.
2. Turn the ignition switch to ACCESSORY or turn a MASTER POWER SWITCH on, if applicable.
3. Turn the room control panel KEY SWITCH to the "ON" position.
4. To retract the room press and hold the ROOM CONTROL SWITCH in the "RETRACT" position until the room is fully retracted.

**NOTE:** Hold the switch to "RETRACT" three or four seconds after the room is fully retracted. This assures proper pressurization of the cylinders. **During normal operation of the room, do not reverse direction of the room until the room is fully retracted. If necessary, the direction of the room may be reversed, but watch for binding of the room. If the direction of the room has been reversed, DO NOT retract the room until the room has been fully extended.**

**IMPORTANT:** Do not hold the ROOM CONTROL SWITCH in the "RETRACT" position for more than ten seconds after the room is fully retracted or stops moving.

**If either side of the room stops moving, release the room control switch immediately. DO NOT force the room. DO NOT reverse direction of the room, contact HWH Customer Service for assistance 1-800-321-3494.**

**NOTE:** Releasing the ROOM CONTROL SWITCH will halt the operation of the room.

5. Turn the room control panel KEY SWITCH to the "OFF" position.
6. Turn the ignition switch off, if applicable.
7. If the room will not retract see the MANUAL ROOM RETRACT PROCEDURE.

**IMPORTANT:** Room-locking devices should be locked while traveling.

# MANUAL ROOM AND GENERATOR SLIDE RETRACT PROCEDURE (WITH SOLENOID VALVES WITH VALVE RELEASE NUTS)

(USE ONLY WHEN THE ROOM WILL NOT RETRACT WITH THE ROOM CONTROL SWITCH)

## OVERVIEW

The room can be retracted manually if a hydraulic or electric failure prevents the room from being retracted using the CONTROL SWITCH. For normal retract sequence see the ROOM SLIDE RETRACT PROCEDURES. Refer to the vehicle manufacturer for storage location of the winch and information for connecting the winch to the room.

**IMPORTANT:** If the vehicle is not equipped with a winch, DO NOT use other pulling devices to retract the room. Follow steps 2 and 3 and try pushing the room in. Contact the vehicle manufacturer or HWH Customer Service at 1-800-321-3494 or 563-724-3396 for assistance.

**CAUTION:** THE MANUAL RETRACT WINCH IS EQUIPPED FOR MANUALLY RETRACTING THE ROOM ONLY. IT IS NOT TO BE USED FOR LIFTING OR ANY OTHER APPLICATION. HIGH FORCES ARE CREATED WHEN USING A WINCH, CREATING POTENTIAL SAFETY HAZARDS. FAILURE TO FOLLOW ALL CAUTIONS AND INSTRUCTIONS MAY CAUSE FAILURE OF THE MANUAL RETRACT WINCH OR CONNECTIONS RESULTING IN DAMAGE OR PERSONAL INJURY. MAINTAIN FIRM GRIP ON THE WINCH HANDLE AT ALL TIMES. NEVER RELEASE THE HANDLE WHEN RATCHET LEVER IS IN THE OFF POSITION AND THE WINCH IS LOADED. THE WINCH HANDLE COULD SPIN VIOLENTLY AND CAUSE PERSONAL INJURY. CHECK THE WINCH AND STRAPS FOR DAMAGE OR WEAR, AND CHECK FOR PROPER RATCHET OPERATION ON EACH USE OF THE WINCH. DO NOT USE IF DAMAGED OR WORN.

1. Retract jacks following the LEVELING SYSTEM RETRACT PROCEDURE.

**NOTE :** When manually retracting the room, make sure the jacks are retracted before retracting the room.

2. Locate the HYDRAULIC PUMP/MANIFOLD unit.

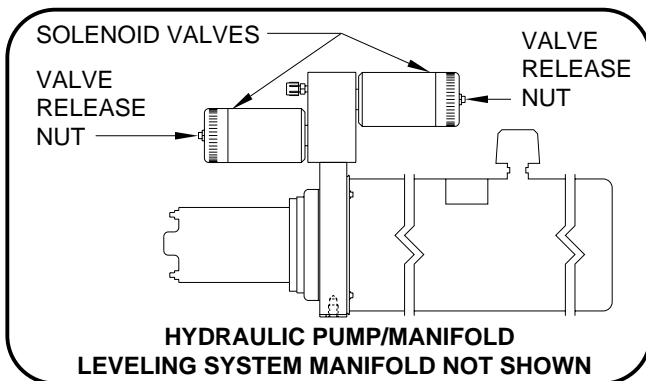

3. Open the Solenoid Valves by slowly turning the valve release nuts counter clockwise using the 1/4" nut driver supplied.

**IMPORTANT:** Only open the valves enough to retract the room. DO NOT turn the release nuts more than 4 and 1/2 turns. Turning the nuts more could damage the valves.

**NOTE:** Prior to APRIL 2002 a 1/4" Nut Driver was sent with the Operators Manual. As of APRIL 2002 the 1/4" Nut Driver has been incorporated into the Breather Cap. See the back page of this manual for further info.

**NOTE:** The room may move slightly as the SOLENOID VALVES are opened and internal pressure is released.

4. Locate the MANUAL RETRACT WINCH and connect it to the room according to the vehicle manufacturer's instructions. To extend the WINCH STRAP firmly grasp WINCH HANDLE, place RATCHET LEVER in its OFF position, and slowly rotate the WINCH HANDLE counter clockwise, keeping a firm grip on the handle. When enough WINCH STRAP is extended, place the RATCHET LEVER in its ON position and slowly rotate the WINCH HANDLE clockwise until the RATCHET LEVER locks.

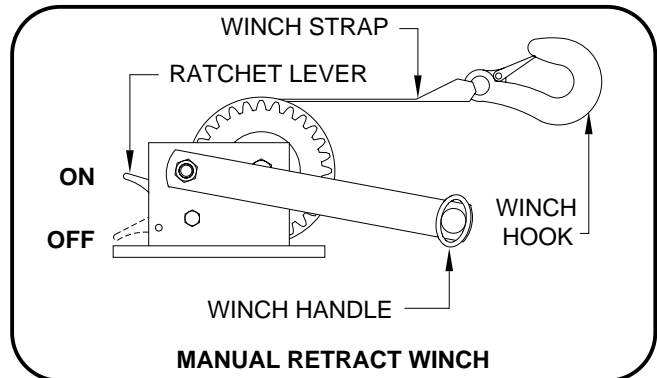

5. Slowly winch the room in by turning the WINCH HANDLE clockwise. The RATCHET LEVER should produce a loud, sharp, clicking noise.

**NOTE:** Winching the room in quickly will raise pressure in the hydraulic fluid and make winching more difficult.

**CAUTION:** OPERATE THE MANUAL RETRACT WINCH BY HAND POWER ONLY. IF THE WINCH CANNOT BE CRANKED EASILY WITH ONE HAND IT IS PROBABLY OVERLOADED. IF WINCHING BECOMES TOO DIFFICULT STOP AND CHECK FOR OBSTRUCTIONS OR RESTRICTIONS ON THE ROOM AND ROOM EXTENSION MECHANISM.

6. When the room is fully retracted, engage the room locking devices. Leave the retract winch engaged and the solenoid valves open.

**CAUTION:** THE ROOM EXTENSION SOLENOID VALVE RELEASE NUTS MUST BE IN THE OPEN POSITION WHEN THE MANUAL RETRACT WINCH IS ENGAGED.

7. The system should be repaired before using again.

**NOTE:** After repairs are made, when closing the VALVE RELEASE NUTS, do not over tighten the nuts.

MP34.9500  
07FEB07

---

# MAINTENANCE

---

## OIL LEVEL

All maintenance should be done as part of the normal servicing of the coach.

The oil level should be checked when the vehicle is first purchased and then once every two years. More often if there is an oil leak in the system.

All jacks and any HWH room extension cylinders should be completely retracted before checking the oil level. The oil reservoir is part of the pump/manifold assembly. The oil level is checked and filled through the breather cap. Clear any dirt away from the breather/filler cap before removing. The oil level should be within one inch of the top of the reservoir. Most breather caps have a dipstick.

**NOTE: Overfilling the tank can cause leakage of oil through the breather cap.**

**FLUID:** HWH Specialty Hydraulic Oil is recommended. In an emergency Dexron automatic transmission fluid can be used. **NOTE:** Dexron automatic transmission fluid contains red dye and can cause staining should a leak occur. **DO NOT USE** brake fluid or hydraulic jack fluid. Use of these can damage seals.

## ELECTRICAL SYSTEM

The batteries should be in good condition and fully charged. Weak batteries can cause erratic operation. Battery cable terminals and battery posts and connections should be kept clean.

All electrical connections, especially ground connections, should be clean, tight, free from corrosion and protected from weathering.

## JACKS

There are very few user serviceable parts on the jacks. The jacks require very little maintenance. If the jacks are extremely dirty with caked on mud they should be washed.

The jack rods should NOT be wiped and do not need to be oiled or sprayed with anything.

## ROOM EXTENSIONS

The HWH room mechanisms need no maintenance. **DO NOT** grease or lubricate any parts of the HWH mechanism.

Any visible mechanism can be kept clean by washing with water. Refer to the vehicle manufacturer for correct maintenance of the room seals.

## VISUAL INSPECTION

Periodically inspect the system for oil leaks and damaged or missing parts, such as pivot bolts or springs. Check the hydraulic lines and wiring for damage and wear.

Check that the jacks do not interfere with any parts of the vehicle when they are in the "STORE" position.

## OPERATIONAL CHECK

Review the OPERATOR MANUAL. Run the system according to the SYSTEM OPERATION Section. Note any abnormal operation.

Review the "JACK RETRACTION" Section. Make sure the jacks will fully retract to the "STORE" position. Jacks should not interfere with any of the coach when in the "STORE" position.

Check that all lights work according to the "INDICATOR LIGHT" Section. Correct function of the red "WARNING" light is important.

# MAINTENANCE/SERVICE

## SENSING UNIT ADJUSTMENT

Level the vehicle by placing a bubble level in the center of the freezer floor or upon whichever surface within the vehicle that is to be level. Using the Leveling System and the bubble level, ignoring the yellow LEVEL lights on the Touch Panel, level the vehicle until the bubble is centered.

With the vehicle level according to the bubble level, if there are no yellow lights lit on the Touch Panel, the sensing unit is properly adjusted. If there are yellow LEVEL lights lit on the Touch Panel, manual adjustments to the Sensing Unit are needed. A 7/8", 3/4" or 5/16" socket w/driver or box end wrench and a philips screw driver will be needed.

The Sensing Unit is mounted inside the Control Box. The Control Box is mounted to the power unit/valve assembly.

There are four LED's on the Sensing Unit, A,B,C and D. Refer to the drawing below. The Sensing Unit is adjusted by turning the adjustment nut to turn out LED's B and D. The adjustment screw will turn out LED's A and C. If the adjustment nut has to be turned more than 1/2 flat or the adjustment screw has to be turned more than 3/4 turn to turn the LED out, there may be a problem with the Sensing Unit or the mounting of the Control Box. If two LED's are on, it is best to make the B-D adjustments first, then hold the adjustment nut from moving while making the A-C adjustment.

**NOTE: If opposing LED's are lit, there is a problem with the Sensing Unit.**

**If LED (A) is lit: Turn the adjustment screw COUNTER CLOCKWISE until the LED is off.**

**If LED (C) is lit: Turn the adjustment screw CLOCKWISE until the LED is off.**

**If LED (B) is lit: Turn the adjustment nut COUNTER CLOCKWISE until the LED is off.**

**If LED (D) is lit: Turn the adjustment nut CLOCKWISE until the LED is off.**

**IMPORTANT: When all 4 LED's are off, move the vehicle to an unlevel position so one or two yellow lights are on. Level the vehicle according to the yellow LEVEL lights. Recheck the level. If more adjustment is needed, DO NOT try to adjust the sensing unit until the yellow level lights go out, instead just "tweak" the sensing unit, ignoring the LED's on the sensing unit.**

**Example: After the initial adjustment and releveling the vehicle, the front is still low. This means the front yellow level light is turning off too soon. Determine which sensing unit light is the front light, A-B-C or D. Move the adjustment for that light very, very, slightly in the OPPOSITE direction that is given in the above instructions for LED's A, B, C, and D. This will allow the front yellow light to stay on slightly longer to bring the front up more. Again, unlevel the vehicle then relevel the vehicle using the yellow level lights on the touch panel. Recheck with a level. Repeat the "tweaking" process until the system levels the vehicle properly.**

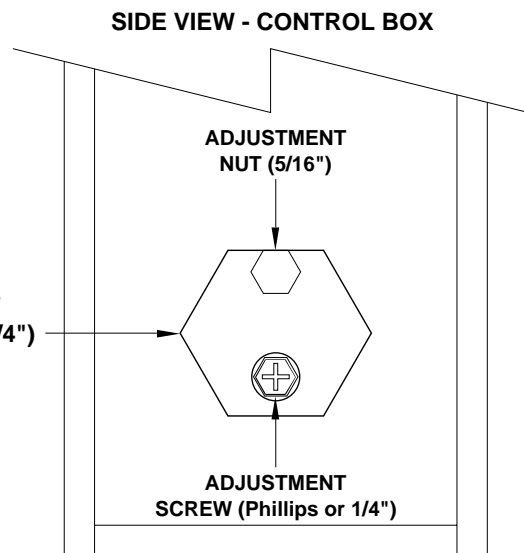
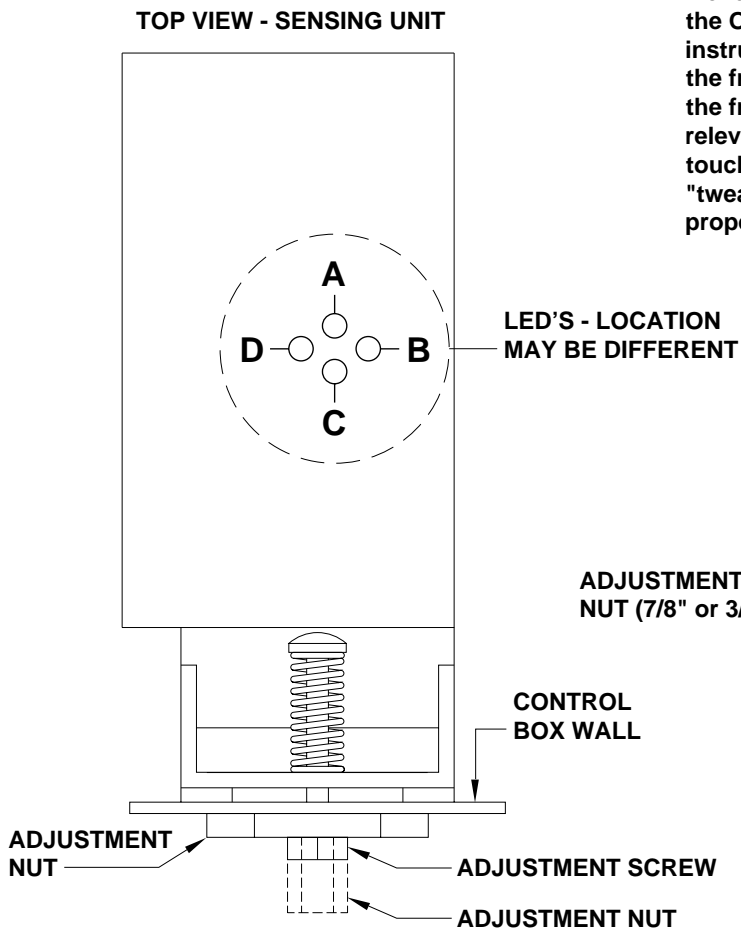

MP44.1500  
07MAR07

# BREATHER CAP - DIPSTICK - 1/4" NUT DRIVER

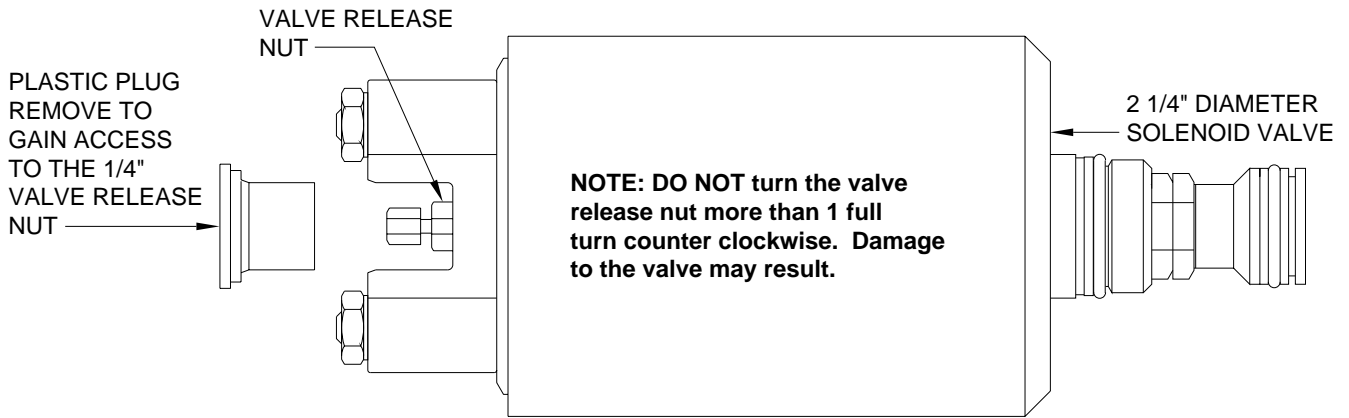
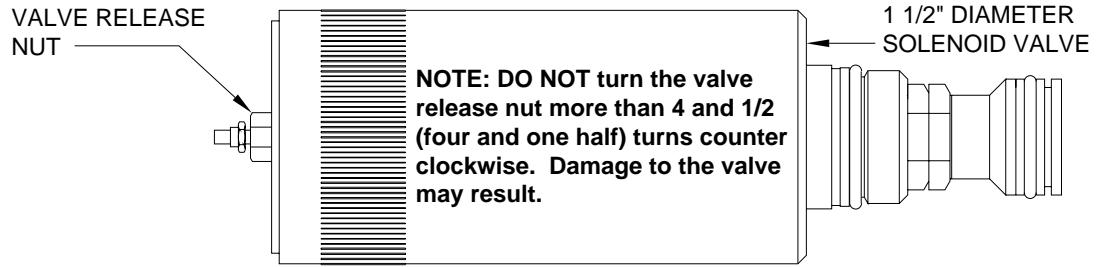

**NOTE: THE BREATHER CAP IS LOCATED ON THE TOP SIDE OF THE POWER UNIT RESERVOIR.**

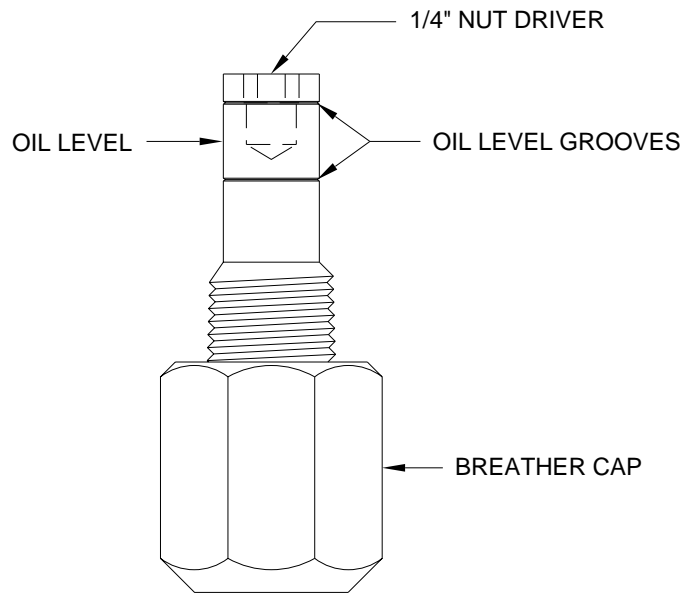

**IMPORTANT: PRIOR TO REMOVING THE BREATHER CAP, EITHER TO CHECK THE OIL LEVEL OR TO USE THE 1/4" NUT DRIVER, CLEAN ANY DEBRIS FROM THE TOP OF THE RESERVOIR. BEFORE RETURNING THE BREATHER CAP TO THE RESERVOIR, REMOVE ANY PAINT CHIPS OR OTHER DEBRIS FROM THE DIPSTICK INCLUDING DEBRIS INSIDE THE 1/4" NUT DRIVER.**