



OPERATOR'S MANUAL

HWH® TOUCH PANEL-CONTROLLED 325 SERIES LEVELING SYSTEM FOR TRAILERS

FEATURING:

*Touch Panel Control
Hydraulic Leveling
Straight-Acting Jacks
With Jack Stop Rods*

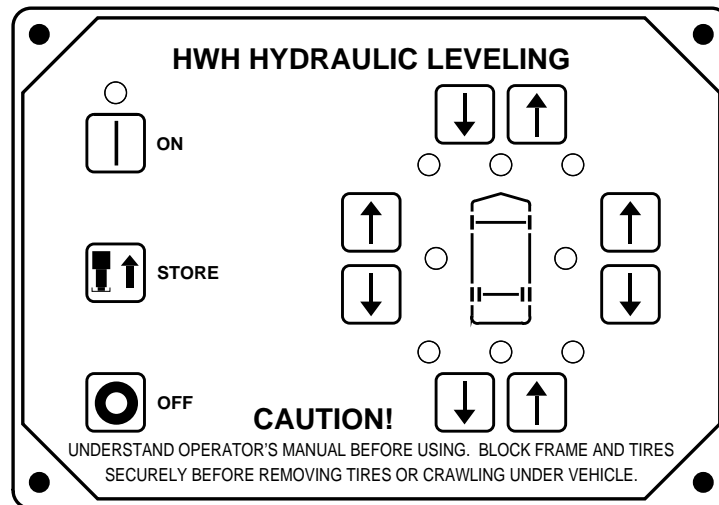

HWH CORPORATION

(On I-80, Exit 267 South)

2096 Moscow Road | Moscow, Iowa 52760

Ph: 800/321-3494 (or) 563/724-3396 | Fax: 563/724-3408

www.hwh.com

OPERATOR'S MANUAL

CAUTION !

READ THE ENTIRE OPERATOR'S MANUAL BEFORE OPERATING.

BLOCK FRAME AND TIRES SECURELY BEFORE CRAWLING UNDER VEHICLE. DO NOT USE LEVELING JACKS OR AIR SUSPENSION TO SUPPORT VEHICLE WHILE UNDER VEHICLE OR CHANGING TIRES. VEHICLE MAY DROP AND/OR MOVE FORWARD OR BACKWARD WITHOUT WARNING CAUSING INJURY OR DEATH.

KEEP ALL PEOPLE CLEAR OF VEHICLE WHILE LEVELING SYSTEM IS IN USE.

DO NOT LIFT TOW VEHICLE WITH LEVELING SYSTEM.

SET FRONT JACK STOP RODS AFTER LEVELING OR PARKING THE TRAILER. WHILE SETTING STOP RODS, HITCHING OR UNHITCHING, AVOID AREAS WHERE BODY MAY BE CRUSHED BY SUDDEN DROPPING OR SLIDING OF THE TRAILER.

DO NOT USE THE LEVELING JACKS IF STOP RODS, RETAINING PINS OR GUIDES BECOME DAMAGED, LOST OR IN ANY WAY INOPERATIVE.

NEVER PLACE HANDS OR OTHER PARTS OF THE BODY NEAR HYDRAULIC LEAKS. OIL MAY PENETRATE SKIN CAUSING INJURY OR DEATH.

WEAR SAFETY GLASSES WHEN INSPECTING OR SERVICING THE SYSTEM TO PROTECT EYES FROM DIRT, METAL CHIPS, OIL LEAKS, ETC. FOLLOW ALL OTHER APPLICABLE SHOP SAFETY PRACTICES.

IMPORTANT: IF VEHICLE IS EQUIPPED WITH A ROOM EXTENSION, READ ROOM EXTENSION SECTION BEFORE OPERATING LEVELING SYSTEM.

HOW TO OBTAIN WARRANTY SERVICE

THIS IS NOT TO BE INTERPRETED AS A STATEMENT OF WARRANTY

HWH CORPORATION strives to maintain the highest level of customer satisfaction. Therefore, if you discover a defect or problem, please do the following:

FIRST: Notify the dealership where you purchased the vehicle or had the leveling system installed. Dealership management people are in the best position to resolve the problem quickly. If the dealer has difficulty solving the problem, he should immediately contact the Customer Service Department, at HWH CORPORATION.

SECOND: If your dealer cannot or will not solve the problem, notify the Customer Service Department:
HWH CORPORATION 2096 Moscow Rd. Moscow IA. 52760
(563) 724-3396 OR (800) 321-3494. Give your name and address, coach manufacturer and model year, date the coach was purchased, or the date of system installation,

description of the problem, and where you can be reached during business hours (8:00 a.m. till 5:00 p.m. c.s.t.). HWH CORPORATION personnel will contact you to determine whether or not your claim is valid. If it is, HWH CORPORATION will authorize repair or replacement of the defective part, either by appointment at the factory or by the authorization of an independent service facility, to be determined by HWH CORPORATION. All warranty repairs must be performed by an independent service facility authorized by HWH CORPORATION, or at the HWH CORPORATION factory, unless prior written approval has been obtained from proper HWH CORPORATION personnel.

CONTROL IDENTIFICATION

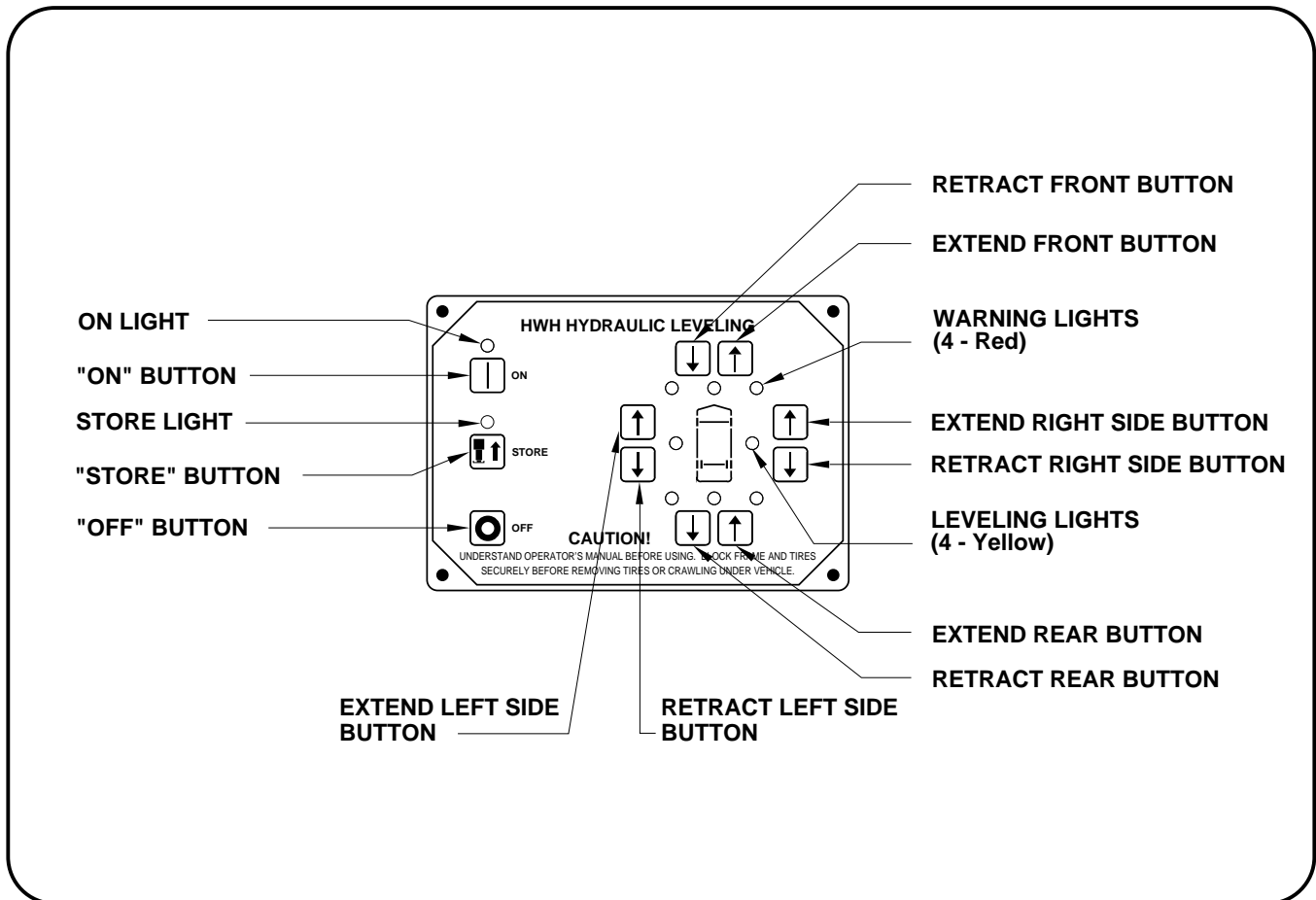

CONTROL FUNCTIONS

CONTROL BUTTONS

"ON" BUTTON: This is the "ON" button for the leveling system.

"OFF" BUTTON: This button turns off control power to the leveling system.

"STORE" BUTTON: This button will retract all four jacks at the same time. It is to be used only after the trailer has been hitched to the tow vehicle.

EXTEND BUTTONS (UP ARROWS): These buttons will extend their respective jacks and raise the trailer.

RETRACT BUTTONS (DOWN ARROWS): These buttons will retract their respective jacks and lower the trailer.

NOTE: Side arrows operate the rear jacks only.

INDICATOR LIGHTS

ON LIGHT: This light indicates the system is on.

STORE LIGHT: This light indicates the leveling system is in the STORE mode.

LEVELING LIGHTS: If a yellow LEVELING light is on, that indicates a side or end of the trailer is low. Extend the appropriate jack pairs to put out the yellow light. One or two yellow LEVELING lights can be on at the same time. The trailer is level when all yellow lights are out.

WARNING LIGHTS: Fifth wheel trailers are equipped with straight-acting jacks. The respective red WARNING light will be on if a straight-acting jack is extended approximately 1/4 to 1/2 inch.

OPERATING PROCEDURES

ROOM EXTENSION PROCEDURES

IMPORTANT: If the vehicle is equipped with a room extension read this section carefully.

IMPORTANT: It is recommended to level and stabilize the vehicle before extending the room.

IMPORTANT: Extending or retracting any leveling jacks when the room is extended is not recommended.

Refer to the vehicle owner's manual for proper operation of room extensions.

IMPORTANT: Do not use a room extension support when the vehicle is supported by the leveling system.

SET UP PROCEDURE

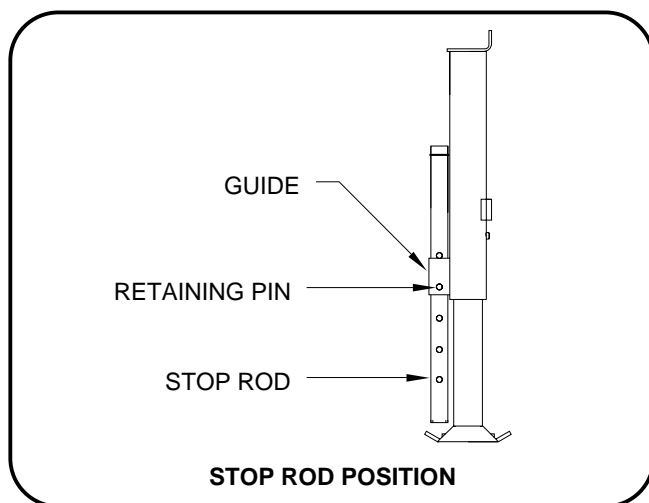

1. Trailer must be unhitched from the tow vehicle before leveling. The HWH front jacks may be used to lift the trailer for unhitching. If auxiliary jacks are used to unhitch the trailer, extend the HWH front jacks to the ground and retract the auxiliary jacks before the leveling system is used for leveling.

NOTE: Refer to the trailer manufacturer owner's manual for unhitching.

If parking on soft ground or asphalt paving, a wood block or pad should be placed under each jack.

IMPORTANT: Overheating and excessive current drain will result if raise arrows are operated for an extended period of time.

2. The touch panel must be on for the system to function.

3. Lower the front of the trailer until the front yellow level indicator lights come on. This is done by pushing the front RETRACT button (DOWN ARROW). The red jacks down warning lights will light when the jacks are extended 1/4 to 1/2 inch.

4. A lit yellow LEVEL light indicates that the side, end or corner of the trailer is low. Pushing the up arrow for corresponding yellow level lights will extend that jack or jack pair to level the vehicle. Extend jacks as needed to put out all the yellow lights. Always give a side yellow level light priority when leveling the trailer. If the ground is too uneven, the jacks may not have enough stroke to level the trailer. The trailer may have to be moved.

NOTE: When a side arrow (UP or DOWN) is pushed only the rear jack on that side will extend or retract.

5. After the trailer is level, the jacks not used for leveling may be extended until they touch the ground. This provides additional stability against wind and activity in the trailer. Jacks used to stabilize the trailer should lift the trailer about 3/4 inch.

6. Push the "OFF" button on the touch panel to turn the system off.

7. The jack stop rods should be adjusted immediately after the leveling and stabilizing procedure is finished.

NOTE: The jack stop rods should be set anytime the trailer is supported by the front jacks.

CAUTION: WHILE SETTING STOP RODS AVOID AREAS WHERE BODY MAY BE CRUSHED BY SUDDEN DROPPING OR SLIDING OF TRAILER.

A. Remove retaining pin to allow stop rod to drop down to the foot of the jack.

B. Lift stop rod as needed (up to 4") to align the hole in the guide with the nearest available hole in the stop rod. Insert the retaining pin through the holes in the guide and stop rod. Latch the keeper wire for the retaining pin.

OPERATING PROCEDURES

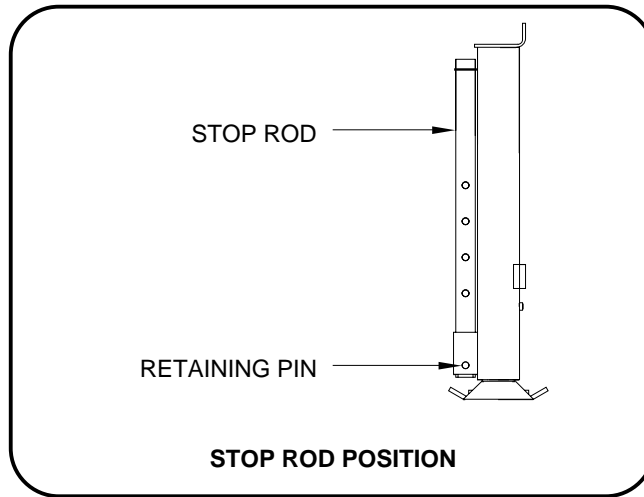

PREPARATION FOR TRAVEL

1. Before retracting the jacks, the stop rods must be returned to the travel position.

CAUTION: WHEN STORING THE JACK STOP RODS, AVOID AREAS WHERE BODY MAY BE CRUSHED BY SUDDEN DROPPING OR SLIDING OF TRAILER.

a. Remove the retaining pin. If the trailer weight is on the stop rods, the front jacks may have to be extended slightly to free the retaining pin.

b. Lift the stop rod to align the bottom hole in the stop rod with the hole in the guide. Insert the retaining pin through both holes and latch the retaining pin keeper wire.

2. Push the "ON" button.

3. Push and hold the rear RETRACT button until the rear WARNING lights are out.

4. Hitch the trailer to the tow vehicle using the front UP (extend jacks) DOWN (retract jacks) arrows according to the procedure supplied by the trailer manufacturer.

5. When the vehicle is securely hitched to the tow vehicle, push the "STORE" button. All four jacks will retract. The panel will automatically turn off 2 minutes after the last of the four red warning lights go out. If any red warning light remains on, the system will try to store the jacks for 20 minutes from the time the "STORE" button is pushed, then turn off.

CAUTION: ONLY USE THE "STORE" BUTTON IF THE TRAILER IS HITCHED TO A TOW VEHICLE.

6. Press the "OFF" button to turn the system off.

7. Visually inspect all of the jacks to make sure they are fully retracted before moving the trailer.

OPERATING PROCEDURES MANUAL JACK RETRACTION FOR TRAILERS WITHOUT LOCK VALVE

MANUAL JACK RETRACTION

CAUTION: KEEP AWAY FROM THE WHEELS, DO NOT CRAWL UNDER THE VEHICLE, KEEP A SAFE DISTANCE IN FRONT AND REAR OF THE VEHICLE. THE VEHICLE MAY DROP AND/OR MOVE FORWARD OR BACKWARD WITHOUT WARNING AS THE VALVE RELEASE IS OPERATED.

IMPORTANT: HWH recommends that all HWH room extensions are fully retracted prior to performing manual jack retraction procedures.

Use the manual valve release for retracting the jacks only if the STORE feature on the HWH control panel will not retract the jacks.

1. Locate your power unit-manifold assembly. (The diagram below represents a typical Power Unit-Manifold Assembly it may not be an exact match to yours).

NOTE: Multiple manifolds may be present on the power unit. The upper most manifold should control jack functions. (Valve styles and arrangements will vary)

2. Allow clearance for the vehicle to lower. If equipped with landing gear, lower the landing gear to support the trailer while manually retracting the jacks.

3. Using the diagrams below identify the style and location of your two front jack control valves.

NOTE: As of APRIL 2002 a 1/4" Nut Driver has been incorporated into the Breather Cap. Before using read and understand the last page of this manual.

Small style with Valve Release Nut: DO NOT turn the 1/4" valve release nut more than 4 and 1/2 turns. Turning the nut more could damage the valve.

Large style with T-Handle valve release: The T-Handle will turn several turns easily. As the valve starts to open, the T-Handle will turn harder. Make sure the valves have been opened far enough to allow the jacks to retract.

Large style with Valve Release Nut: The 1/4" Valve release nut is located under a plastic plug that must be removed to gain access. DO NOT turn the 1/4" valve release nut more than 1 full turn. Turning the nut more could damage the valve.

NOTE: The stop rods must be returned to the travel position before retracting the front jacks.

4. Retract the front jacks by opening the correct valves. Slowly turn the manual valve releases counter clockwise until the jacks start to retract. Hitch the trailer to the tow vehicle during this operation if the vehicle is not equipped with an alternate landing gear.

5. Repeat the process by identifying then opening the two rear control valves.

6. Check that all jacks are now retracted. If yes, continue. If no, notify the dealership where you purchased the vehicle or had the leveling system installed or contact HWH Corporation customer service.

7. Close the valves by turning each valve release clockwise.

IMPORTANT: Once the manual valve release is snug, DO NOT tighten the manual valve release past this point as internal damage may occur to the solenoid.

8. Retract all landing gear before traveling.

9. The system should now be repaired before using again.

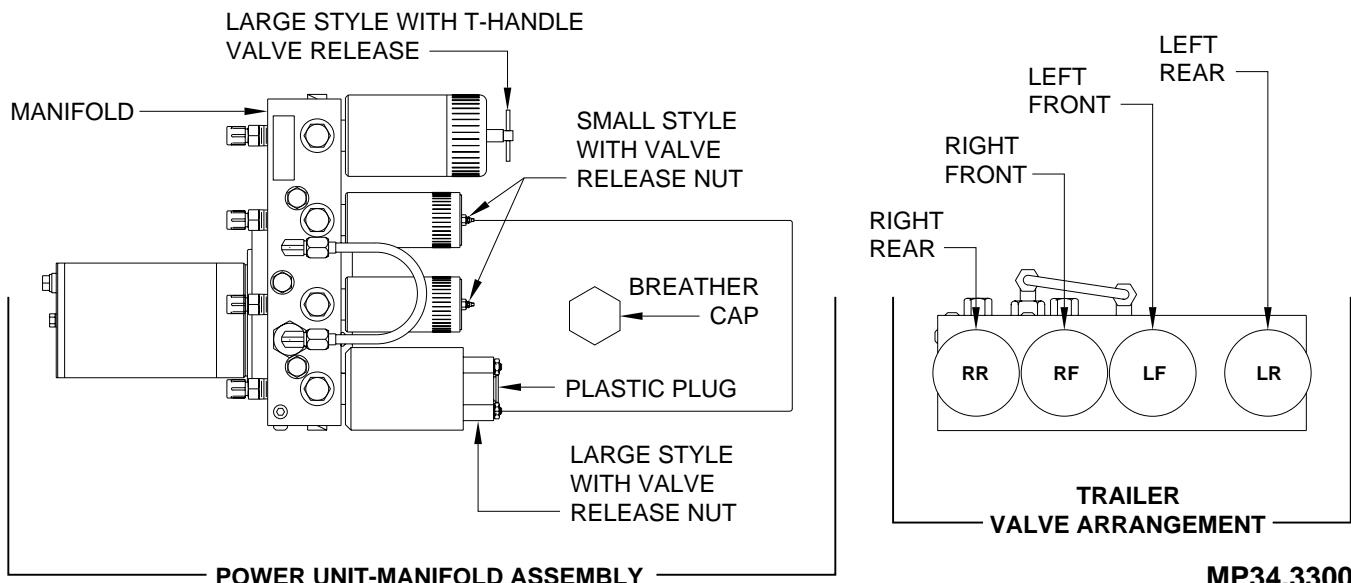

OPERATING PROCEDURES MANUAL JACK RETRACTION FOR TRAILERS WITH LOCK VALVE

MANUAL JACK RETRACTION

CAUTION: KEEP AWAY FROM THE WHEELS, DO NOT CRAWL UNDER THE VEHICLE, KEEP A SAFE DISTANCE IN FRONT AND REAR OF THE VEHICLE. THE VEHICLE MAY DROP AND/OR MOVE FORWARD OR BACKWARD WITHOUT WARNING AS THE VALVE RELEASE IS OPERATED.

IMPORTANT: HWH recommends that all HWH room extensions are fully retracted prior to performing manual jack retraction procedures.

Use the manual valve release for retracting the jacks only if the STORE feature on the HWH control panel will not retract the jacks.

1. Locate your power unit-manifold assembly. (The diagram below represents a typical Power Unit-Manifold Assembly it may not be an exact match to yours).

NOTE: Multiple manifolds may be present on the power unit. The upper most manifold should control jack functions. (Valve styles and arrangements will vary)

2. Allow clearance for the vehicle to lower. If equipped with landing gear, lower the landing gear to support the trailer while manually retracting the jacks.

3. Using the diagrams below identify the style and location of your two rear jack control valves.

NOTE: As of APRIL 2002 a 1/4" Nut Driver has been incorporated into the Breather Cap. Before using read and understand the last page of this manual.

Small style with Valve Release Nut: DO NOT turn the 1/4" valve release nut more than 4 and 1/2 turns. Turning the nut more could damage the valve.

Large style with T-Handle valve release: The T-Handle will turn several turns easily. As the valve starts to open, the T-Handle will turn harder. Make sure the valves have been opened far enough to allow the jacks to retract.

Large style with Valve Release Nut: The 1/4" Valve release nut is located under a plastic plug that must be removed to gain access. DO NOT turn the 1/4" valve release nut more than 1 full turn. Turning the nut more could damage the valve.

4. Retract the rear jacks by opening the correct valves. Slowly turn the manual valve releases counter clockwise until the jacks start to retract.

NOTE: The stop rods must be returned to the travel position before retracting the front jacks.

5. Repeat the process by identifying then opening the two front control valves. Hitch the trailer to the tow vehicle during this operation if the trailer is not equipped with an alternate landing gear.

6. Check that all jacks are now retracted. If yes, continue. If no, notify the dealership where you purchased the vehicle or had the leveling system installed or contact HWH Corporation customer service.

7. Close the valves by turning each valve release clockwise.

IMPORTANT: Once the manual valve release is snug, DO NOT tighten the manual valve release past this point as internal damage may occur to the solenoid.

8. Retract all landing gear before traveling.

9. The system should now be repaired before using again.

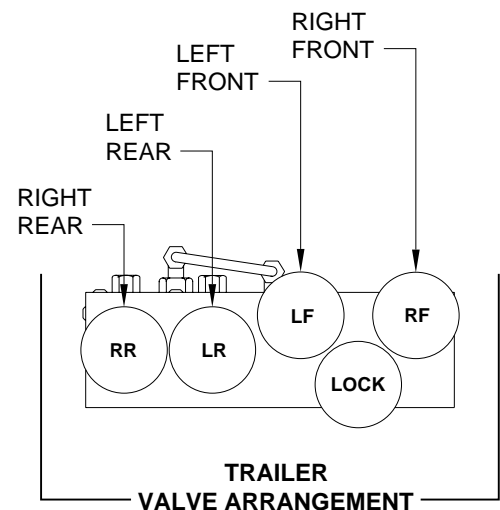
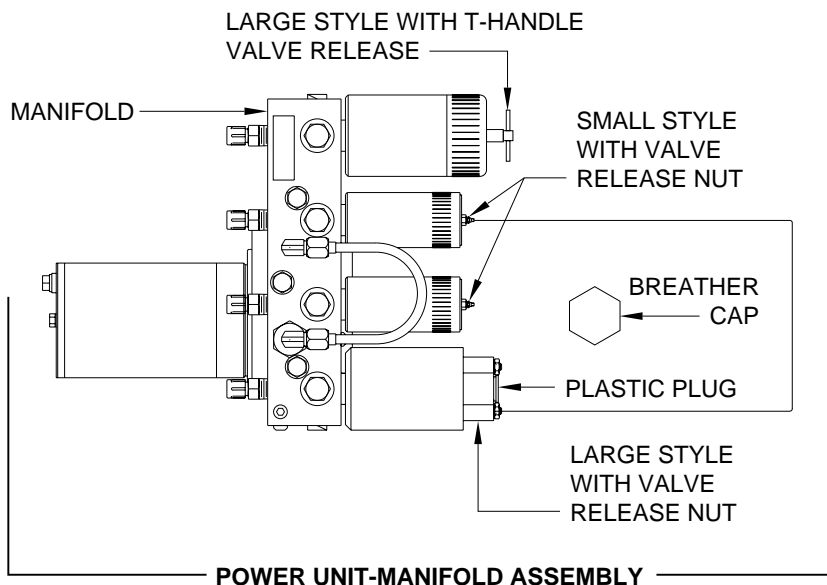

MAINTENANCE

OIL LEVEL

It is important that the four leveling units are fully retracted before checking the hydraulic oil level. To check the oil supply, remove the breather plug from the top of the hydraulic oil reservoir. The oil level should be approximately one inch below the top of the reservoir when adequately filled.

FLUID: HWH Specialty Hydraulic Oil is recommended. In an emergency Dexron automatic transmission fluid can be used.
NOTE: Dexron automatic transmission fluid contains red dye and can cause staining should a leak occur. **DO NOT USE** brake fluid or hydraulic jack fluid. Use of these can damage seals.

UNUSUAL CONDITIONS

In general, to insure the smooth operation of the leveling system, it is a good idea to occasionally check the individual leveling units to prevent problems. This is especially true under the unusual conditions stated in the following:

If driving conditions are unusually muddy, the units may become caked or clogged with mud. This condition may hamper the proper operation of the leveling system. This problem may be prevented or remedied by cleaning off each leveling unit if they become excessively muddy.

In wet or icy weather leveling units may become encrusted with ice. This may cause the leveling system to function improperly. To eliminate this problem, periodically check the leveling units and break loose any ice which may be causing improper operation.

The stop rods and retaining pins on the front jacks must be kept in good operating condition. Clean and lubricate the rod and retaining pin regularly.

Do not move the trailer while the leveling units are still in contact with the ground. Visually check to see if the leveling units have returned to the STORE/TRAVEL position before moving the trailer.

NOTE: All major components of the system can be replaced with rebuilt units or can be sent to HWH CORPORATION to be rebuilt, when the system is out of warranty.

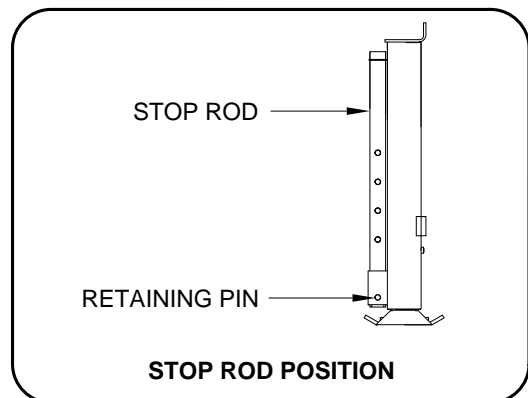

MAINTENANCE/SERVICE

SENSING UNIT ADJUSTMENT

Level the vehicle by placing a bubble level in the center of the freezer floor or upon whichever surface within the vehicle that is to be level. Using the Leveling System and the bubble level, ignoring the yellow LEVEL lights on the Touch Panel, level the vehicle until the bubble is centered.

With the vehicle level according to the bubble level, if there are no yellow lights lit on the Touch Panel, the sensing unit is properly adjusted. If there are yellow LEVEL lights lit on the Touch Panel, manual adjustments to the Sensing Unit are needed. A 7/8", 3/4" or 5/16" socket w/driver or box end wrench and a philips screw driver will be needed.

The Sensing Unit is mounted inside the Control Box. The Control Box is mounted to the power unit/valve assembly.

There are four LED's on the Sensing Unit, A,B,C and D. Refer to the drawing below. The Sensing Unit is adjusted by turning the adjustment nut to turn out LED's B and D. The adjustment screw will turn out LED's A and C. If the adjustment nut has to be turned more than 1/2 flat or the adjustment screw has to be turned more than 3/4 turn to turn the LED out, there may be a problem with the Sensing Unit or the mounting of the Control Box. If two LED's are on, it is best to make the B-D adjustments first, then hold the adjustment nut from moving while making the A-C adjustment.

NOTE: If opposing LED's are lit, there is a problem with the Sensing Unit.

If LED (A) is lit: Turn the adjustment screw **COUNTER CLOCKWISE** until the LED is off.

If LED (C) is lit: Turn the adjustment screw **CLOCKWISE** until the LED is off.

If LED (B) is lit: Turn the adjustment nut **COUNTER CLOCKWISE** until the LED is off.

If LED (D) is lit: Turn the adjustment nut **CLOCKWISE** until the LED is off.

IMPORTANT: When all 4 LED's are off, move the vehicle to an unlevel position so one or two yellow lights are on. Level the vehicle according to the yellow LEVEL lights. Recheck the level. If more adjustment is needed, **DO NOT** try to adjust the sensing unit until the yellow level lights go out, instead just "tweak" the sensing unit, ignoring the LED's on the sensing unit.

Example: After the initial adjustment and releveling the vehicle, the front is still low. This means the front yellow level light is turning off too soon. Determine which sensing unit light is the front light, A-B-C or D. Move the adjustment for that light very, very, slightly in the **OPPOSITE** direction that is given in the above instructions for LED's A, B, C, and D. This will allow the front yellow light to stay on slightly longer to bring the front up more. Again, unlevel the vehicle then relevel the vehicle using the yellow level lights on the touch panel. Recheck with a level. Repeat the "tweaking" process until the system levels the vehicle properly.

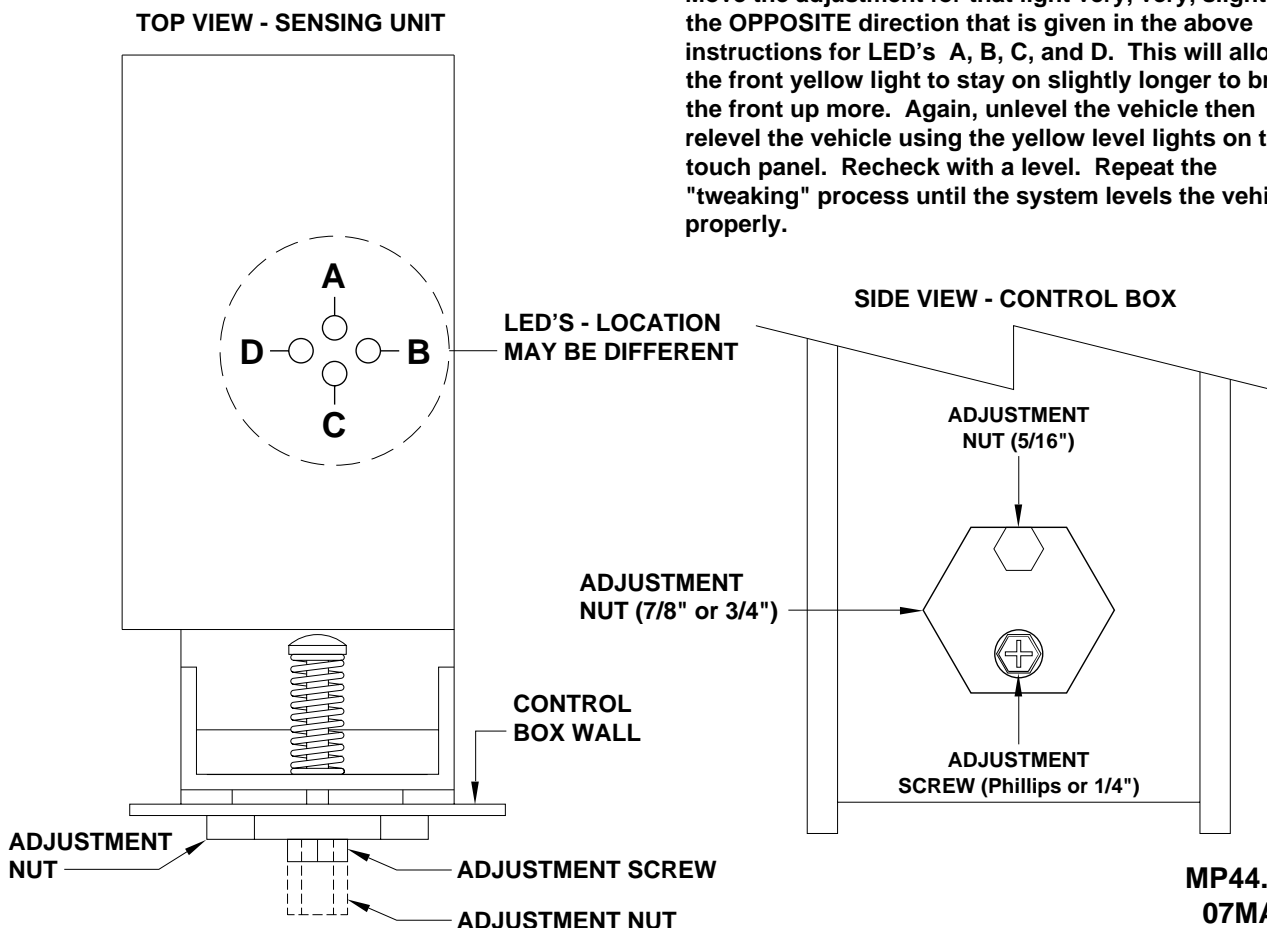

MP44.1500
07MAR07

BREATHER CAP - DIPSTICK - 1/4" NUT DRIVER

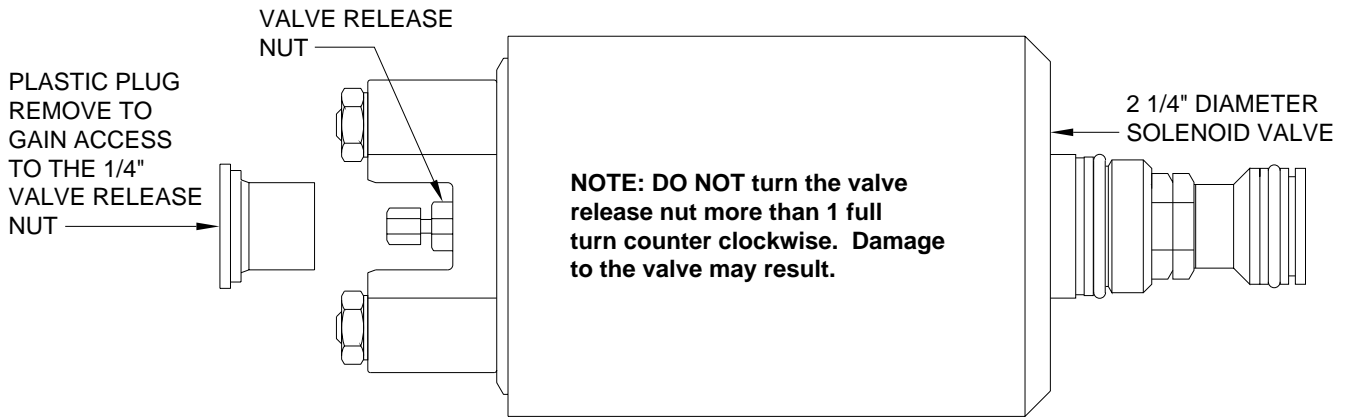
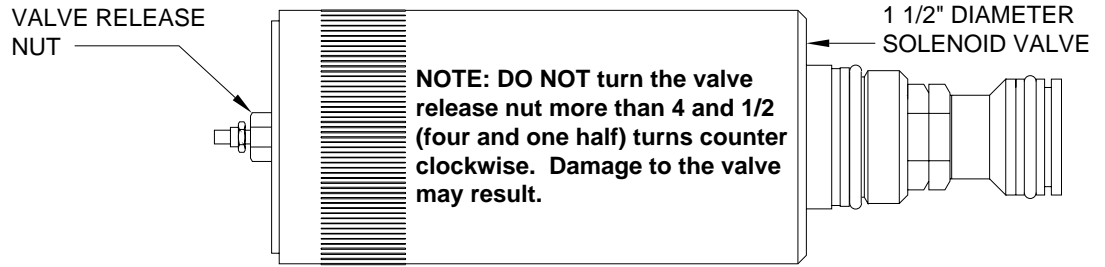

NOTE: THE BREATHER CAP IS LOCATED ON THE TOP SIDE OF THE POWER UNIT RESERVOIR.

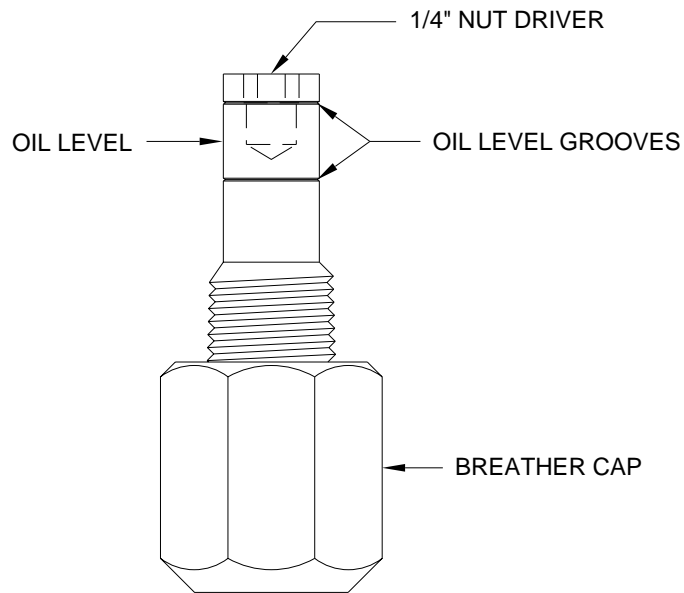

IMPORTANT: PRIOR TO REMOVING THE BREATHER CAP, EITHER TO CHECK THE OIL LEVEL OR TO USE THE 1/4" NUT DRIVER, CLEAN ANY DEBRIS FROM THE TOP OF THE RESERVOIR. BEFORE RETURNING THE BREATHER CAP TO THE RESERVOIR, REMOVE ANY PAINT CHIPS OR OTHER DEBRIS FROM THE DIPSTICK INCLUDING DEBRIS INSIDE THE 1/4" NUT DRIVER.