

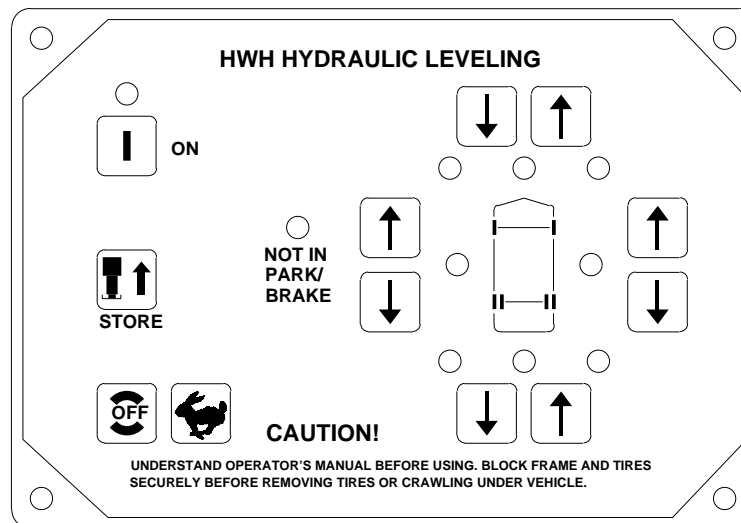

OPERATOR'S MANUAL

HWH TOUCH PANEL-CONTROLLED LEVELING SYSTEM 310 SERIES SPACEMAKER ROOM EXTENSION SYSTEM

FEATURING:
TOUCH PANEL LEVELING CONTROL
HYDRAULIC LEVELING
STRAIGHT-ACTING JACKS
PILOT OPERATED AIR DUMP
ONE DUAL CYLINDER "LEVEL FLOOR" ROOM EXTENSION
(WITH SYNCHRONIZING CYLINDER)



HWH CORPORATION
(ON I-80, EXIT 267 SOUTH)
2096 MOSCOW ROAD
MOSCOW, IOWA 52760
(800) 321-3494 / (563) 724-3396
INTERNET: <http://www.hwhcorp.com>

OPERATOR'S MANUAL

CAUTION !

READ THE ENTIRE OPERATOR'S MANUAL BEFORE OPERATING.

BLOCK FRAME AND TIRES SECURELY BEFORE CRAWLING UNDER VEHICLE. DO NOT USE LEVELING JACKS OR AIR SUSPENSION TO SUPPORT VEHICLE WHILE UNDER VEHICLE OR CHANGING TIRES. VEHICLE MAY DROP AND OR MOVE FORWARD OR BACKWARD WITHOUT WARNING CAUSING INJURY OR DEATH.

KEEP ALL PEOPLE CLEAR OF THE VEHICLE WHILE LEVELING SYSTEM AND ROOM EXTENSIONS ARE BEING OPERATED.

KICK-DOWN JACKS MAY ABRUPTLY SWING UP WHEN THE FOOT OF THE JACK CLEARS THE GROUND OR WHEN THE JACK REACHES FULL EXTENSION.

NEVER PLACE HANDS OR OTHER PARTS OF THE BODY NEAR HYDRAULIC LEAKS. OIL MAY PENETRATE THE SKIN CAUSING INJURY OR DEATH.

WEAR SAFETY GLASSES WHEN INSPECTING OR SERVICING THE SYSTEM TO PROTECT EYES FROM DIRT, METAL CHIPS, OIL LEAKS, ETC. FOLLOW ALL OTHER APPLICABLE SHOP SAFETY PRACTICES.

IF THE VEHICLE IS EQUIPPED WITH KICK-DOWN STYLE JACKS, DO NOT OVER EXTEND THE REAR JACKS. IF THE WEIGHT OF THE VEHICLE IS REMOVED FROM ONE OR BOTH REAR WHEELS, THE VEHICLE MAY ROLL FORWARD OR BACKWARD OFF OF THE JACKS.

NOTE: KEEP THE CONTROL VALVE LEVERS IN THE STORE POSITION WHEN JACKS ARE NOT IN USE.

IMPORTANT: IF VEHICLE IS EQUIPPED WITH A ROOM EXTENSION, READ ROOM EXTENSION SECTION BEFORE OPERATING LEVELING SYSTEM.

HOW TO OBTAIN WARRANTY SERVICE

THIS IS NOT TO BE INTERPRETED AS A STATEMENT OF WARRANTY

HWH CORPORATION strives to maintain the highest level of customer satisfaction. Therefore, if you discover a defect or problem, please do the following:

FIRST: Notify the dealership where you purchased the vehicle or had the leveling system installed. Dealership management people are in the best position to resolve the problem quickly. If the dealer has difficulty solving the problem, he should immediately contact the Customer Service Department, at HWH CORPORATION.

SECOND: If your dealer cannot or will not solve the problem, notify the Customer Service Department:
HWH CORPORATION 2096 Moscow Rd. Moscow IA. 52760
(563) 724-3396 OR (800) 321-3494. Give your name and address, coach manufacturer and model year, date the coach was purchased, or the date of system installation,

description of the problem, and where you can be reached during business hours (8:00 a.m. till 5:00 p.m. c.s.t.). HWH CORPORATION personnel will contact you to determine whether or not your claim is valid. If it is, HWH CORPORATION will authorize repair or replacement of the defective part, either by appointment at the factory or by the authorization of an independent service facility, to be determined by HWH CORPORATION. All warranty repairs must be performed by an independent service facility authorized by HWH CORPORATION, or at the HWH CORPORATION factory, unless prior written approval has been obtained from proper HWH CORPORATION personnel.

CONTROL IDENTIFICATION

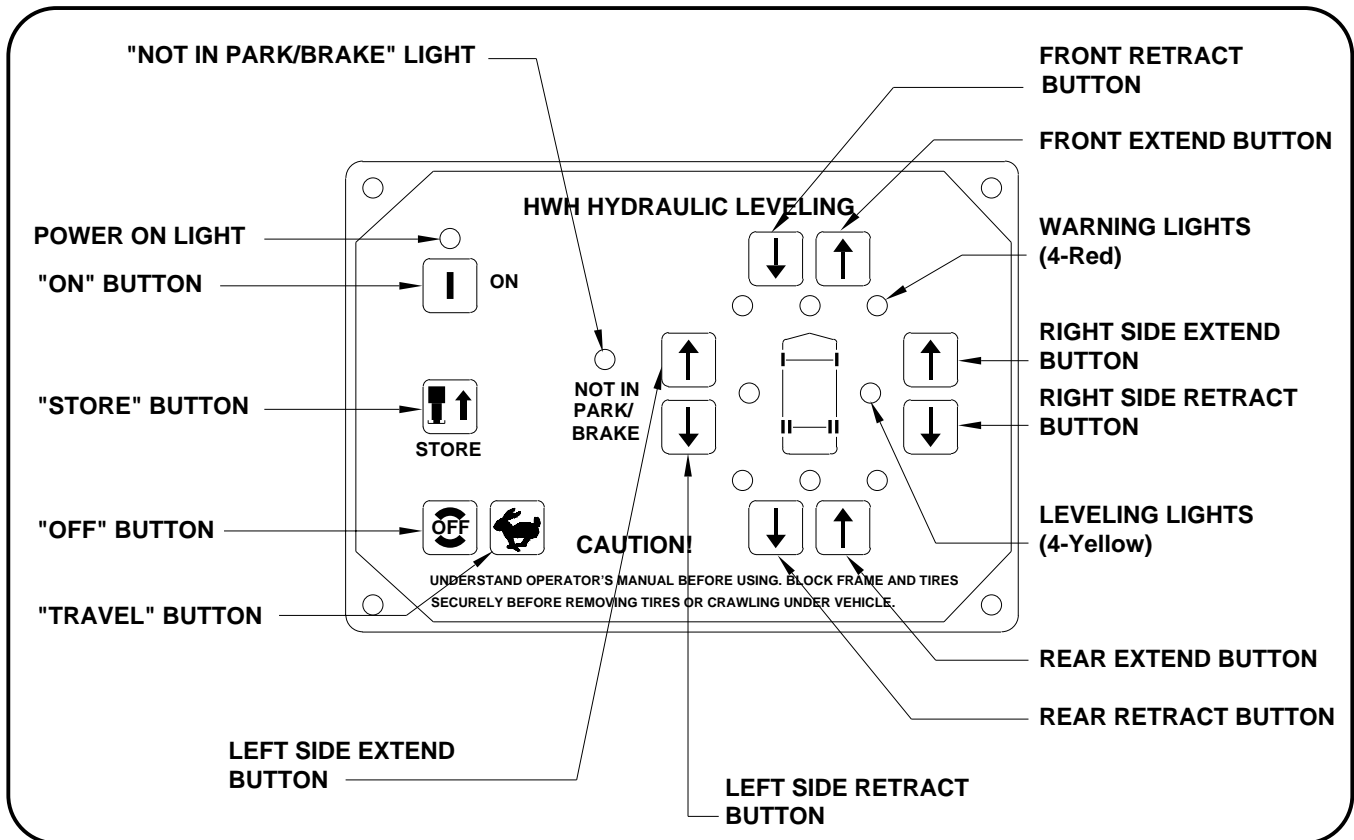

CONTROL FUNCTIONS

CONTROL BUTTONS

"ON" BUTTON : This is the "ON" button for the leveling system. It provides control power to operate the electrical relay on the pump, the LEVELING lights and the 4 red WARNING lights.

"OFF" BUTTON : This button turns off control power to the leveling system.

"STORE" BUTTON : This button will retract all four jacks at the same time.

EXTEND BUTTONS (UP ARROWS) : These buttons will extend their respective jack pairs to lift the vehicle.

RETRACT BUTTONS (DOWN ARROWS) : These buttons will retract their respective jack pairs to lower the vehicle.

"TRAVEL" BUTTON: This button will return the vehicle suspension to the TRAVEL mode when pushed. (See Pilot Operated Air Dump.)

INDICATOR LIGHTS

POWER ON LIGHT: This light indicates the system is on.

STORE LIGHT: This light will be on when the system is in the store mode.

"NOT IN PARK/BRAKE" LIGHT: This indicator light is on when the panel is on, but the hand/auto park brake is not set.

LEVELING LIGHTS: If a yellow LEVELING light is on, that indicates a side, corner, or end of the vehicle is low. Extend the appropriate jack pairs to put out the yellow light. Only one yellow LEVELING light can be on at a time. The vehicle is level when all yellow lights are out.

WARNING LIGHTS: A red WARNING light will be on whenever the corresponding jack is extended approximately 1 to 2 inches, provided the ignition is in the "ACC" or "ON" position and the system is on. Some vehicles are equipped with a dash mounted master "JACKS DOWN" light which will be on when one or more jacks are extended approximately 1 to 2 inches, if the ignition is in the "ON" position.

WARNING BUZZER: A buzzer will sound if a jack is extended 1 to 2 inches or more and the ignition switch is in the "ON" position.

OPERATING PROCEDURES

SITE SELECTION

Maintain adequate clearance in all directions for vehicle, room extensions, awnings, doors, steps, etc. Vehicle may move in any direction due to jack extending or retracting, settling of

jacks or vehicle, equipment malfunction, etc. If parking on soft ground or asphalt paving, wood blocks or pads should be placed under the jacks.

PREPARATION FOR TRAVEL

Before traveling, the jacks down warning indicators must be off. If a jacks down warning indicator is on, retract jacks as described in the JACK RETRACTION Section.

All room extensions must be fully retracted before moving the vehicle.

If the jacks are retracted but a warning indicator is on, the system needs to be serviced.

CAUTION: DO NOT MOVE THE VEHICLE WHILE THE LEVELING JACKS ARE STILL IN CONTACT WITH THE GROUND OR IN THE EXTEND POSITION. THIS VEHICLE IS EQUIPPED WITH STRAIGHT-ACTING JACKS. MOVING THE VEHICLE WITH THE LEVELING JACKS EXTENDED CAN CAUSE SEVERE DAMAGE TO

THE JACKS AND OR THE VEHICLE AND CREATE A DRIVING HAZARD. DO NOT RELY SOLELY UPON WARNING LIGHTS. IT IS THE OPERATOR'S RESPONSIBILITY TO VISUALLY CHECK THAT ALL JACKS ARE FULLY RETRACTED INTO THE STORE/TRAVEL POSITION AND THE VEHICLE'S SUSPENSION HAS RETURNED TO THE PROPER RIDE HEIGHT FOR TRAVEL. DO NOT MOVE THE VEHICLE IF ANY ROOM EXTENSION IS EXTENDED. ROOMS MUST BE FULLY RETRACTED BEFORE MOVING THE VEHICLE. SEE THE MANUAL ROOM RETRACT PROCEDURE IF THE ROOM CANNOT BE RETRACTED WITH THE ROOM EXTENSION OPERATOR'S PANEL.

If the jacks cannot be retracted according to the JACK RETRACTION Section, retract the jacks according to the MANUAL JACK RETRACTION Section. The system should then be checked.

LEVELING PROCEDURE

IMPORTANT: Do not operate the room extension without first leveling and stabilizing the vehicle.

NOTE: The leveling system will not function while a room is being operated.

1. Place gear selector in the parking position, apply park brake and block tires securely.

NOTE: If the hand/auto park brake is not set, the "NOT IN PARK/BRAKE" light will come on when the "ON" button is pushed. The panel will turn on, but the system will not operate.

2. Turn ignition switch to "ACCESSORY".

3. Push the "ON" button on the touch panel. The POWER ON light will be lit. The air will exhaust from the suspension air bags. Wait until the air is completely exhausted before continuing. Place a pad under each jack, if necessary at this time.

4. A lit yellow LEVEL light indicates that end, side or corner is low. Push an EXTEND (up arrow) button to extend jack pairs according to a lit yellow light. ALWAYS LEVEL THE VEHICLE FROM SIDE TO SIDE BEFORE LEVELING THE VEHICLE FRONT TO REAR. Only one yellow LEVEL light can be on at one time. Extend jack pairs accordingly until all yellow lights are out. If the ground is too uneven, the jacks may not have enough stroke to level the vehicle. The vehicle may have to be moved.

5. After the vehicle is level, the jacks not used for leveling may be extended until they touch the ground and slightly lift the vehicle. This provides additional stability against wind and activity in the vehicle. Do this by pushing the front and/or rear EXTEND buttons as needed to extend any remaining jacks. Do not use the right or left EXTEND buttons.

6. Push the "OFF" button on the touch panel.

7. Turn the ignition switch off.

OPERATING PROCEDURES

PILOT OPERATED AIR DUMP

DUMP

The vehicle ignition switch must be in the "ON" or "ACC" position and the park brake must be set.

To dump air from the suspension, set the park brake, turn the ignition to "ON" or "ACC". Push the "ON" button on the leveling system panel. Air will exhaust from the suspension airbags.

The suspension will stay in the dump mode until the park brake is released or the "TRAVEL" button is pushed, if the ignition is in the "ON" or "ACC" position.

CAUTION: THE VEHICLE WILL DROP QUICKLY WHEN THE "ON" BUTTON IS PUSHED. MAKE SURE PEOPLE AND OBJECTS ARE CLEAR OF THE VEHICLE BEFORE PUSHING THE "ON" BUTTON.

TRAVEL

To return the vehicle to travel the ignition key must be in the "ON" or "ACC" position. The suspension will return to the travel mode if the "TRAVEL" button is pushed. The leveling system panel does not have to be on. If the ignition is in "ON" or "ACC" the suspension will also return to the travel mode if the park brake is released.

CAUTION: IT IS THE OPERATOR'S RESPONSIBILITY TO CHECK THAT THE VEHICLE IS AT THE PROPER RIDE HEIGHT FOR TRAVELING BEFORE MOVING THE VEHICLE. THE VEHICLE MAY ROLL FORWARD OR BACKWARD WHEN THE PARK BRAKE IS RELEASED.

OPERATING PROCEDURES

ROOM EXTEND PROCEDURE

NOTE: The park brake must be set before a room can be extended or retracted.

CAUTION: OPERATING A ROOM WITH ANY ROOM LOCKING, CLAMPING OR MANUAL RETRACTING DEVICES ATTACHED OR ENGAGED CAN CAUSE PERSONAL INJURY AND VEHICLE DAMAGE. IT IS THE OPERATOR'S RESPONSIBILITY TO ENSURE THAT ALL ROOM LOCKING, CLAMPING OR MANUAL RETRACTING DEVICES ARE DETACHED OR DISENGAGED BEFORE OPERATING THE ROOM.

It is recommended to complete the Leveling Procedure before operating room extensions.

1. Level the vehicle using the hydraulic leveling system.
2. Unlock all room-locking devices.

NOTE: If the MANUAL RETRACT WINCH is attached to the room remove it before extending the room.

CAUTION: KEEP PEOPLE AND OBSTRUCTIONS CLEAR OF ROOM WHEN OPERATING.

NOTE: Make sure there is adequate clearance to fully extend the room.

3. To extend the room, press and hold the ROOM CONTROL SWITCH in the "EXTEND" position until the room is fully extended.

NOTE: Hold the switch to "EXTEND" three or four seconds after the room is fully extended. This assures proper pressurization of the cylinders. **During normal operation of the room, do not reverse direction of the room until the room is fully extended. If necessary, the direction of the room may be reversed, but watch for binding of the room. If the direction of the room has been reversed, DO NOT re-extend the room until the room has been fully retracted.**

IMPORTANT: Do not hold the ROOM CONTROL SWITCH in the "EXTEND" position for more than ten seconds after the room is fully extended or stops moving. **If either side of the room stops moving, release the room control switch immediately. DO NOT force the room. DO NOT reverse direction of the room, contact HWH Customer Service for assistance 1-800-321-3494.**

NOTE: Releasing the ROOM CONTROL SWITCH will halt the operation of the room.

ROOM RETRACT PROCEDURE

NOTE: The park brake must be set before a room can be extended or retracted.

CAUTION: KEEP PEOPLE AND OBSTRUCTIONS CLEAR OF ROOM WHEN OPERATING.

It is recommended to retract room extensions before retracting jacks.

1. To retract the room press and hold the ROOM CONTROL SWITCH in the "RETRACT" position until the room is fully retracted.

NOTE: Hold the switch to "RETRACT" three or four seconds after the room is fully retracted. This assures proper pressurization of the cylinders. **During normal operation of the room, do not reverse direction of the room until the room is fully retracted. If necessary, the direction of the room may be reversed, but watch for binding of the room. If the direction of the room has been reversed, DO NOT retract the room until the room has been fully extended.**

IMPORTANT: Do not hold the ROOM CONTROL SWITCH in the "RETRACT" position for more than ten seconds after the room is fully retracted or stops moving. **If either side of the room stops moving, release the room control switch immediately. DO NOT force the room. DO NOT reverse direction of the room, contact HWH Customer Service for assistance 1-800-321-3494.**

NOTE: Releasing the ROOM CONTROL SWITCH will halt the operation of the room.

2. Engage all room-locking devices.

3. If the room will not retract see the MANUAL ROOM RETRACT PROCEDURE.

IMPORTANT: Room-locking devices should be locked while traveling.

OPERATING PROCEDURES

SITE SELECTION

Maintain adequate clearance in all directions for vehicle, room extensions, awnings, doors, steps, etc. Vehicle may move in any direction due to jack extending or retracting, settling of

jacks or vehicle, equipment malfunction, etc. If parking on soft ground or asphalt paving, wood blocks or pads should be placed under the jacks.

PREPARATION FOR TRAVEL

Before traveling, the jacks down warning indicators must be off. If a jacks down warning indicator is on, retract jacks as described in the JACK RETRACTION Section.

All room extensions must be fully retracted before moving the vehicle.

If the jacks are retracted but a warning indicator is on, the system needs to be serviced.

CAUTION: DO NOT MOVE THE VEHICLE WHILE THE LEVELING JACKS ARE STILL IN CONTACT WITH THE GROUND OR IN THE EXTEND POSITION. THIS VEHICLE IS EQUIPPED WITH STRAIGHT-ACTING JACKS. MOVING THE VEHICLE WITH THE LEVELING JACKS EXTENDED CAN CAUSE SEVERE DAMAGE TO

THE JACKS AND OR THE VEHICLE AND CREATE A DRIVING HAZARD. DO NOT RELY SOLELY UPON WARNING LIGHTS. IT IS THE OPERATOR'S RESPONSIBILITY TO VISUALLY CHECK THAT ALL JACKS ARE FULLY RETRACTED INTO THE STORE/TRAVEL POSITION AND THE VEHICLE'S SUSPENSION HAS RETURNED TO THE PROPER RIDE HEIGHT FOR TRAVEL. DO NOT MOVE THE VEHICLE IF ANY ROOM EXTENSION IS EXTENDED. ROOMS MUST BE FULLY RETRACTED BEFORE MOVING THE VEHICLE. SEE THE MANUAL ROOM RETRACT PROCEDURE IF THE ROOM CANNOT BE RETRACTED WITH THE ROOM EXTENSION OPERATOR'S PANEL.

If the jacks cannot be retracted according to the JACK RETRACTION Section, retract the jacks according to the MANUAL JACK RETRACTION Section. The system should then be checked.

LEVELING PROCEDURE

IMPORTANT: Do not operate the room extension without first leveling and stabilizing the vehicle.

NOTE: The leveling system will not function while a room is being operated.

1. Place gear selector in the parking position, apply park brake and block tires securely.

NOTE: If the hand/auto park brake is not set, the "NOT IN PARK/BRAKE" light will come on when the "ON" button is pushed. The panel will turn on, but the system will not operate.

2. Turn ignition switch to "ACCESSORY".

3. Push the "ON" button on the touch panel. The POWER ON light will be lit. The air will exhaust from the suspension air bags. Wait until the air is completely exhausted before continuing. Place a pad under each jack, if necessary at this time.

4. A lit yellow LEVEL light indicates that end, side or corner is low. Push an EXTEND (up arrow) button to extend jack pairs according to a lit yellow light. ALWAYS LEVEL THE VEHICLE FROM SIDE TO SIDE BEFORE LEVELING THE VEHICLE FRONT TO REAR. Only one yellow LEVEL light can be on at one time. Extend jack pairs accordingly until all yellow lights are out. If the ground is too uneven, the jacks may not have enough stroke to level the vehicle. The vehicle may have to be moved.

5. After the vehicle is level, the jacks not used for leveling may be extended until they touch the ground and slightly lift the vehicle. This provides additional stability against wind and activity in the vehicle. Do this by pushing the front and/or rear EXTEND buttons as needed to extend any remaining jacks. Do not use the right or left EXTEND buttons.

6. Push the "OFF" button on the touch panel.

7. Turn the ignition switch off.

MANUAL ROOM RETRACT PROCEDURE (WITH SOLENOID VALVES WITH VALVE RELEASE "T" HANDLES)

(USE ONLY WHEN THE ROOM WILL NOT RETRACT WITH THE ROOM CONTROL SWITCH)

OVERVIEW

The room can be retracted manually if a hydraulic or electrical failure prevents the room from being retracted using the ROOM CONTROL SWITCH. For normal retract sequence see the ROOM RETRACT PROCEDURE.

CAUTION: THE MANUAL RETRACT WINCH IS EQUIPPED FOR MANUALLY RETRACTING THE ROOM ONLY. IT IS NOT TO BE USED FOR LIFTING OR ANY OTHER APPLICATION. HIGH FORCES ARE CREATED WHEN USING A WINCH, CREATING POTENTIAL SAFETY HAZARDS. FAILURE TO FOLLOW ALL CAUTIONS AND INSTRUCTIONS MAY CAUSE FAILURE OF THE MANUAL RETRACT WINCH OR CONNECTIONS RESULTING IN DAMAGE OR PERSONAL INJURY. MAINTAIN FIRM GRIP ON THE WINCH HANDLE AT ALL TIMES. NEVER RELEASE THE HANDLE WHEN RATCHET LEVER IS IN THE OFF POSITION AND THE WINCH IS LOADED. THE WINCH HANDLE COULD SPIN VIOLENTLY AND CAUSE PERSONAL INJURY. CHECK THE WINCH AND STRAPS FOR DAMAGE OR WEAR, AND CHECK FOR PROPER RATCHET OPERATION ON EACH USE OF THE WINCH. DO NOT USE IF DAMAGED OR WORN.

1. Retract jacks following the LEVELING SYSTEM RETRACT PROCEDURE.

NOTE : When manually retracting the room, make sure the jacks are retracted before retracting the room.

2. Locate the HYDRAULIC PUMP/MANIFOLD unit.

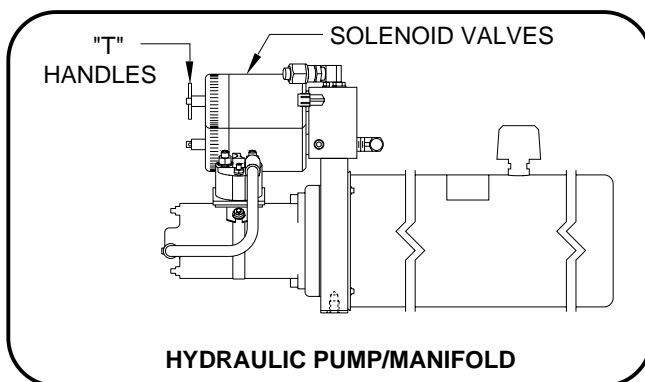

3. Open the SOLENOID VALVES by turning the "T" HANDLES counterclockwise.

NOTE : The "T" HANDLE may turn easily at first but will become more difficult to turn as an internal spring is compressed. Be sure to open both valves completely (about six turns of "T" HANDLE).

NOTE : The room may move slightly as the SOLENOID VALVES are opened and internal pressure is released.

4. Locate the MANUAL RETRACT WINCH and connect it to the room according to the vehicle manufacturer's instructions. To extend the WINCH STRAP firmly grasp WINCH HANDLE, place RATCHET LEVER in its OFF position, and slowly rotate the WINCH HANDLE counterclockwise, keeping a firm grip on the handle. When enough WINCH STRAP is extended, place the RATCHET LEVER in its ON position and slowly rotate the WINCH HANDLE clockwise until the RATCHET LEVER locks.

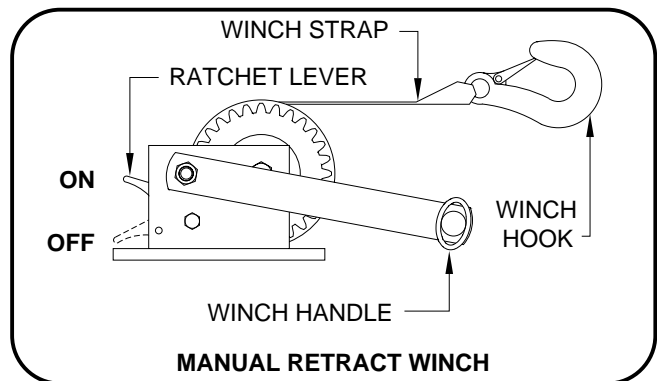

5. Slowly winch the room in by turning the WINCH HANDLE clockwise. The RATCHET LEVER should produce a loud, sharp, clicking noise.

NOTE : Winching the room in quickly will raise pressure in the hydraulic fluid and make winching more difficult.

CAUTION: OPERATE THE MANUAL RETRACT WINCH BY HAND POWER ONLY. IF THE WINCH CANNOT BE CRANKED EASILY WITH ONE HAND IT IS PROBABLY OVERLOADED. IF WINCHING BECOMES TOO DIFFICULT STOP AND CHECK FOR OBSTRUCTIONS OR RESTRICTIONS ON THE ROOM AND ROOM EXTENSION MECHANISM.

6. When the room is fully retracted, engage the room locking devices. Leave the retract winch in place.

CAUTION: THE ROOM EXTENSION SOLENOID VALVE "T" HANDLES MUST BE IN THE OPEN POSITION WHEN THE MANUAL RETRACT WINCH IS ENGAGED.

7. The system should be repaired before using again.

MAINTENANCE

OIL LEVEL

It is important that the four leveling jacks and all HWH room extensions are fully retracted before checking the oil level. To check the oil supply, remove the breather cap from the top of the hydraulic reservoir. The oil level should be approximately one inch below the top of the reservoir when adequately filled.

FLUID: HWH Specialty Hydraulic Oil is recommended. In an emergency Dexron automatic transmission fluid can be used.
NOTE: Dexron automatic transmission fluid contains red dye and can cause staining should a leak occur. **DO NOT USE** brake fluid or hydraulic jack fluid. Use of these can damage seals.

ELECTRICAL SYSTEM

The batteries should be in good condition and fully charged. All electrical connections, especially ground connections, should be clean, tight, free from corrosion and protected

from corrosion. Weak batteries can cause erratic operation. Battery cable terminals, battery posts and connections should be kept clean and protected from corrosion.

UNUSUAL CONDITIONS

If driving conditions are unusually muddy, the jacks may become caked or clogged with mud. This condition may hamper the proper operation of the leveling system. This problem may be prevented or remedied by cleaning off each leveling jack if they become excessively muddy.

Do not move the vehicle while the leveling jacks are still in contact with the ground. Place the system in the store mode and then visually check to see if the leveling jacks have returned to the STORE/TRAVEL position.

In wet or icy weather leveling jacks may become encrusted with ice. This may cause the leveling system to function improperly. To eliminate this problem, periodically check the leveling jacks and break loose any ice which may be causing improper operation.

NOTE: All major components of the system can be replaced with rebuilt parts or can be sent to HWH CORPORATION to be rebuilt, when the system is out of warranty.

LEVEL SENSING UNIT ADJUSTMENT

Level the vehicle by placing a circular bubble level in the center of the freezer floor or location within the vehicle that is to be level. With the vehicle level, adjust the sensing unit until all yellow lights are off. This is done by drawing up the corresponding screw if the sensing unit is mounted below the surface as shown or backing out the corresponding screw if the sensing unit is mounted above the surface. Bump the sensing unit to see that it is settled tight against all three screw heads and still indicates that the unit is level.

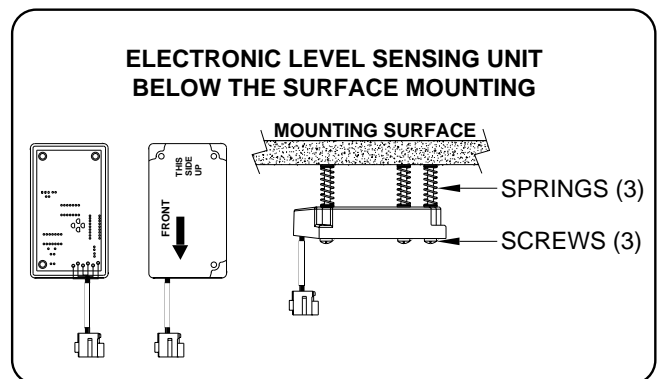
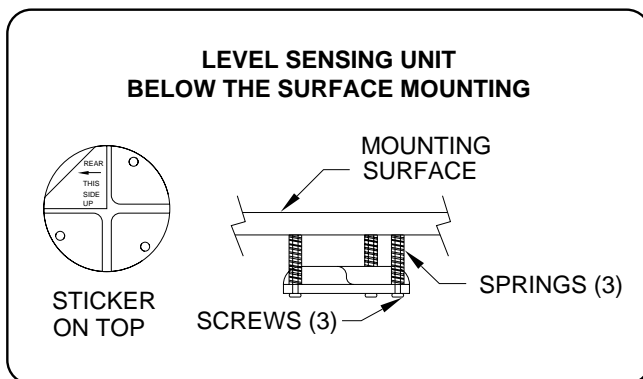

TROUBLE SHOOTING

The following is a list of problems, and possible solutions, which might occur to the leveling system.

NOTE: Only qualified technicians should install or repair leveling systems on vehicles. A knowledge of hydraulics, welding, the vehicle's suspension and electrical system, as well as an understanding of the leveling system's hydraulics and electronics is required.

1. JACK RETRACTS AFTER COACH IS LEVEL.

- A. Hose or jack has external leak.
- B. Fluid is leaking back to reservoir through solenoid valve.
- C. Thermal contraction of the fluid can allow a jack to loosen up if not properly stabilized.

2. LEVELING JACKS WILL NOT RETRACT COMPLETELY.

- A. Jack clogged with mud or ice.
- B. Main rod bent or scored.
- C. Springs weak or broken.
- D. Hydraulic line pinched.
- E. Retract mode interrupted by operating a room extension.

3. IGNITION SWITCH ON, BUT NO POWER TO PUMP AND/OR LIGHTS.

- A. Park brake not set.
- B. 12 volts from main power source not present.
- C. Faulty control box.
- D. Faulty wire or electrical connection.

4. PUMP WILL NOT ACTIVATE.

- A. Bad touch panel.
- B. Bad control box.
- C. Pump relay not functioning.
- D. Pump not grounded.

5. HYDRAULIC PUMP ACTIVATES, BUT THE JACKS WILL NOT EXTEND.

- A. Bad solenoid valve.
- B. Bad manifold pressure switch.
- C. Oil supply low in reservoir.
- D. Pump is not developing pressure.
- E. Broken hydraulic line.
- F. Bad control box.
- G. Bad shuttle valve.

6. LEVELING LIGHTS (YELLOW) NOT FUNCTIONING PROPERLY.

- A. Yellow lights will not go out when vehicle is level: adjust sensing unit.
- B. If more than two yellow lights are on, replace the sensing unit.

7. WARNING LIGHTS (RED) NOT FUNCTIONING PROPERLY.

- A. Light will not come on: check for broken wire at warning switch on the jack or check the touch panel.
- B. Lights will not go out: bad warning switch or wires are shorted to ground or check the touch panel.

8. MASTER WARNING INDICATOR COMES ON WHILE TRAVELING.

- A. Faulty warning switch or wire harness.
- B. STORE mode interrupted by turning the ignition key, pushing the "OFF" button too soon or operating a room extension while in the STORE mode.

TROUBLE SHOOTING ROOM EXTENSION

The following is a list of problems, and possible solutions, which might occur to the room extension systems.

NOTE: Only qualified technicians should install or repair room extension systems. A knowledge of hydraulics, welding and the vehicle's suspension and electrical systems is required. In addition, an understanding of the room extension system's hydraulics and electronics is required.

1. HYDRAULIC PUMP WILL NOT ACTIVATE WHEN ROOM CONTROL SWITCH IS PRESSED.

- A. FUSE is blown.
- B. PUMP RELAY and/or HYDRAULIC PUMP are not properly grounded.
- C. 12 VOLT power to pump relay not present.
- D. Faulty wire, electrical connection, ROOM CONTROL SWITCH, PUMP RELAY, or PUMP MOTOR.
- E. Park brake is not set.

2. HYDRAULIC PUMP ACTIVATES, BUT ROOM WILL NOT EXTEND.

- A. EXTEND SOLENOID VALVE is not properly grounded.
- B. Reservoir oil supply is low.
- C. Hydraulic line is pinched or broken.
- D. Faulty wire, electrical connection, ROOM CONTROL SWITCH, EXTEND SOLENOID VALVE, HYDRAULIC PUMP, or HYDRAULIC CYLINDER.

3. HYDRAULIC PUMP ACTIVATES, BUT ROOM WILL NOT RETRACT.

- A. RETRACT SOLENOID VALVE IS NOT properly grounded.
- B. Reservoir oil supply is low.
- C. Hydraulic line is pinched or broken.
- D. Faulty wire, electrical connection, ROOM CONTROL SWITCH, RETRACT SOLENOID VALVE, HYDRAULIC PUMP, or HYDRAULIC CYLINDER.

4. ROOM CREEPS OUT AFTER CLOSING.

- A. "T" HANDLE or VALVE RELEASE NUT on the EXTEND SOLENOID VALVE is not closed completely.
- B. EXTEND SOLENOID VALVE has an internal leak.
- C. HYDRAULIC CYLINDER has an internal leak.
- D. Manifold check valve is leaking.

5. ROOM CREEPS IN AFTER BEING EXTENDED.

- A. "T" HANDLE on RETRACT SOLENOID valve is not closed completely.
- B. RETRACT SOLENOID valve has an internal leak.

HYDRAULIC SCHEMATIC
305/310/325 SERIES LEVELING SYSTEM
WITH STRAIGHT-ACTING JACKS

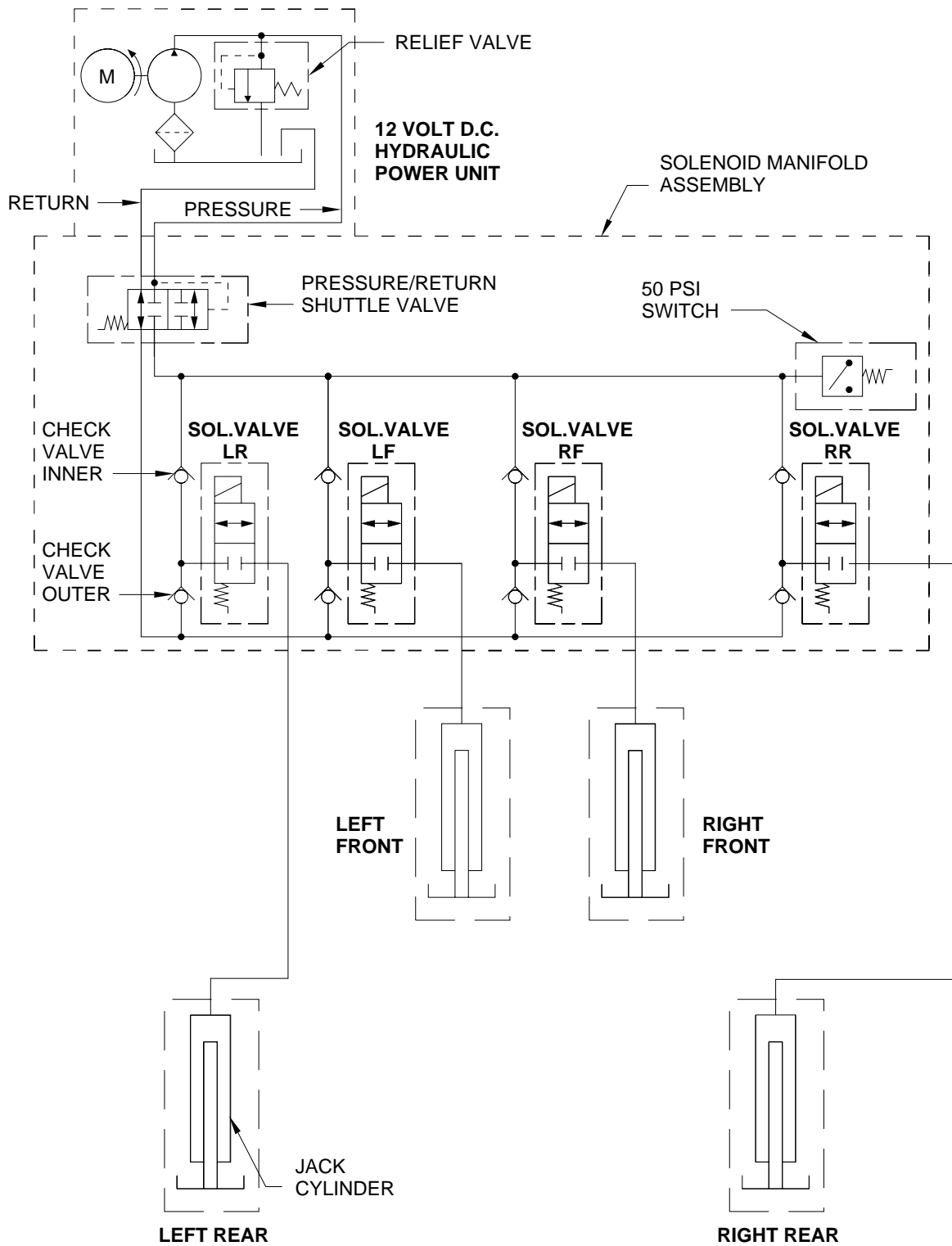

**HYDRAULIC LINE CONNECTION DIAGRAM
TOUCH PANEL CONTROL LEVELING SYSTEM
DUAL CYLINDER "LEVEL FLOOR"
ROOM EXTENSION SYSTEM (W/SYNCHRONIZING CYLINDER)**

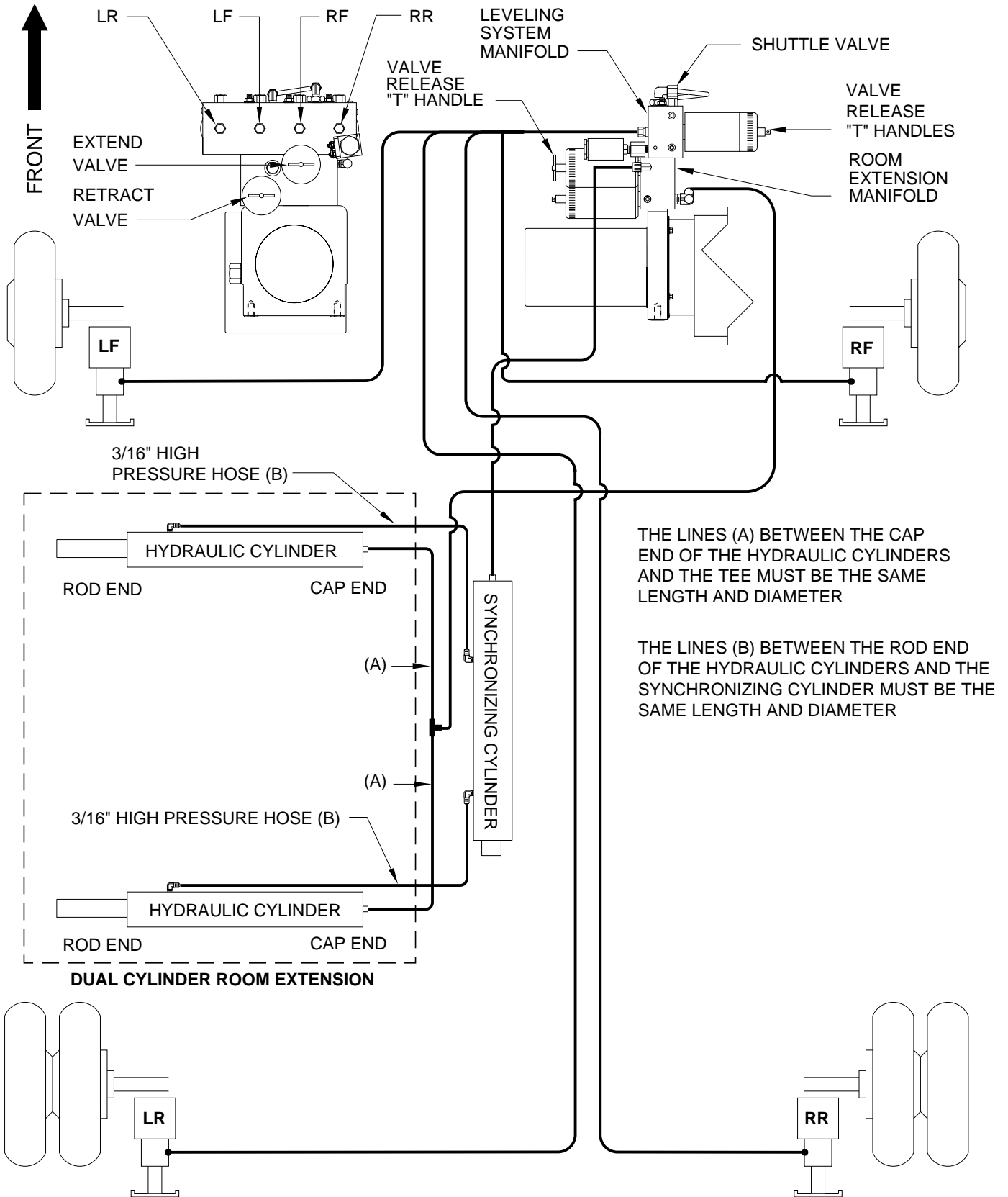

**HYDRAULIC FLOW DIAGRAM
VERTICAL ARM OR DUAL CYLINDER ROOM EXTENSION
WITH SYNCHRONIZING CYLINDER
STATIONARY POSITION**

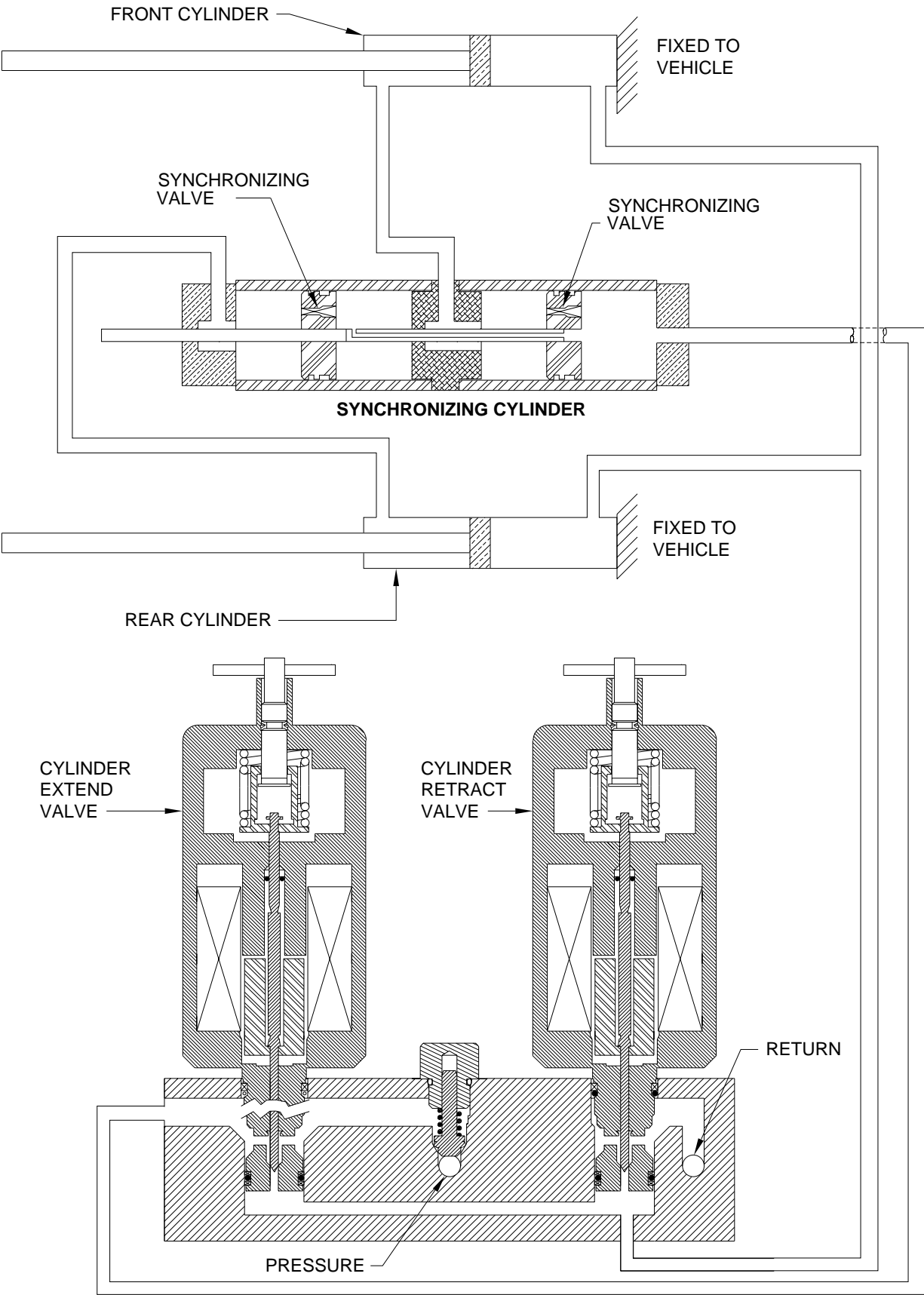

ELECTRICAL CONNECTION DIAGRAM

CONTROL BOX

310 SERIES LEVELING SYSTEM

(WITH PILOT AIR)

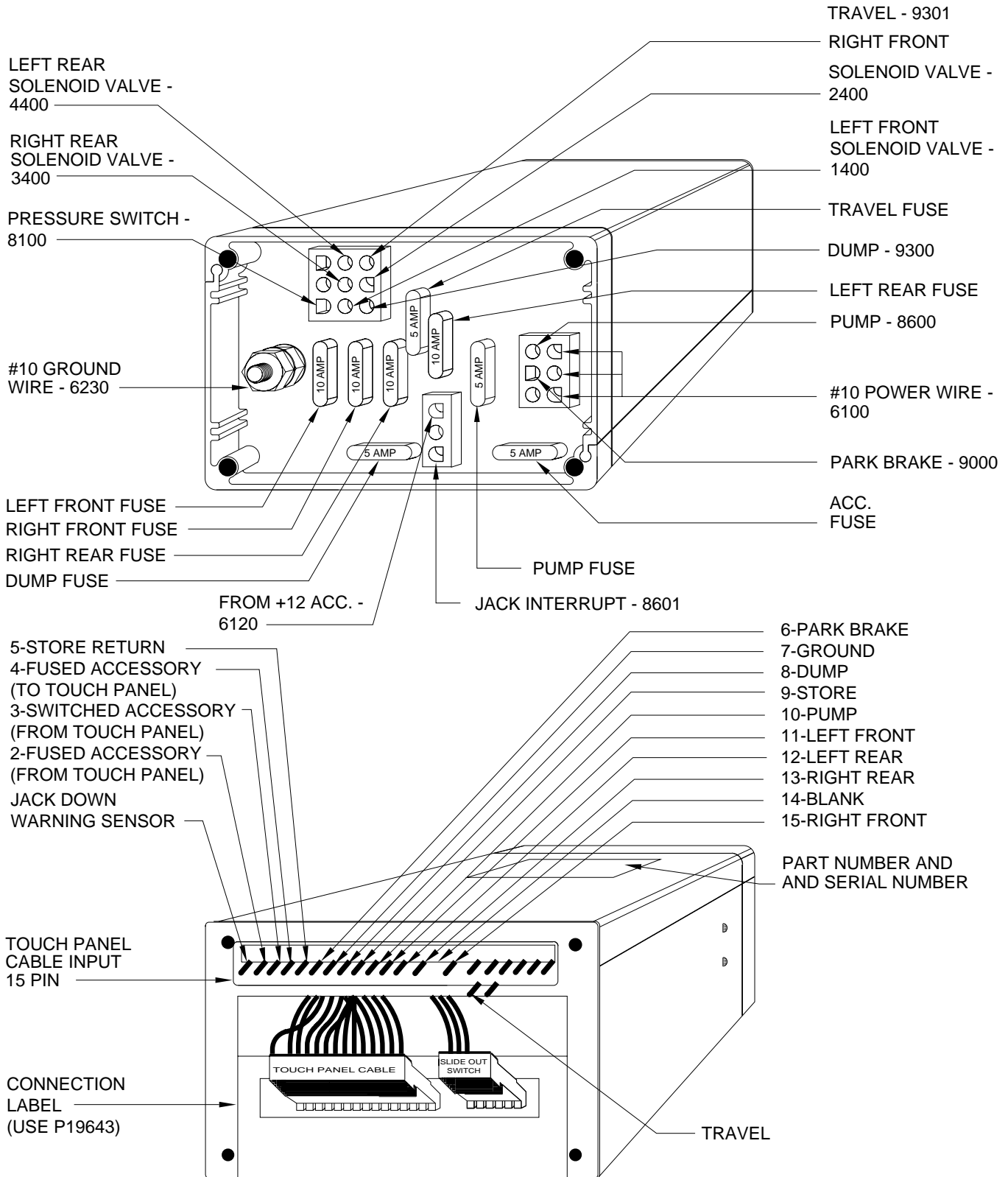

CONNECTION DIAGRAM TOUCH PANEL

310 SERIES LEVELING SYSTEM WITH PILOT AIR DUMP

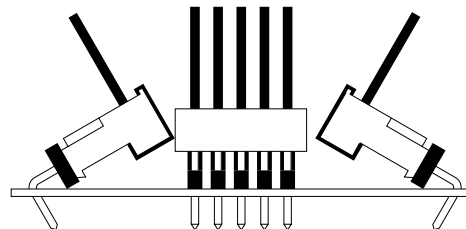
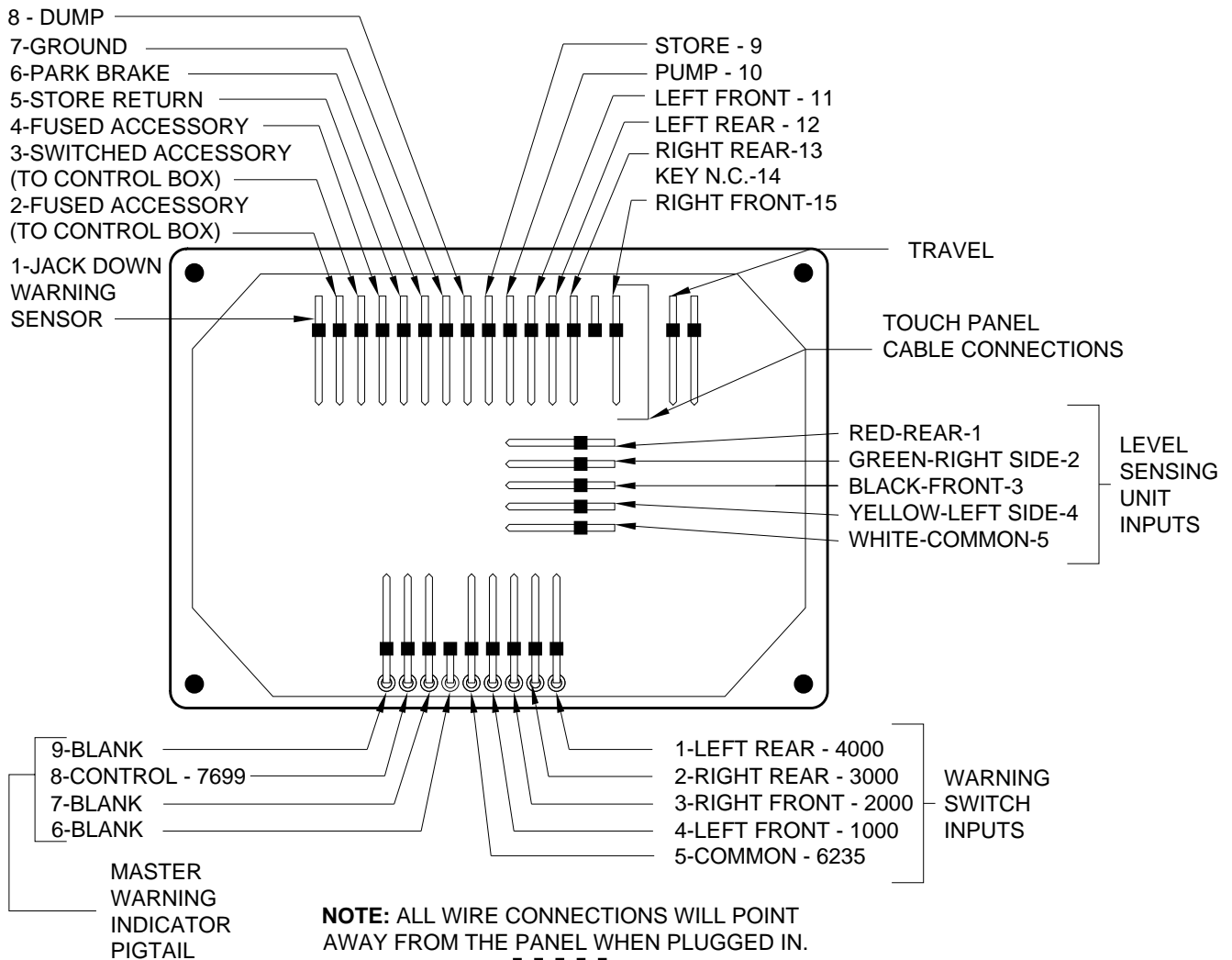
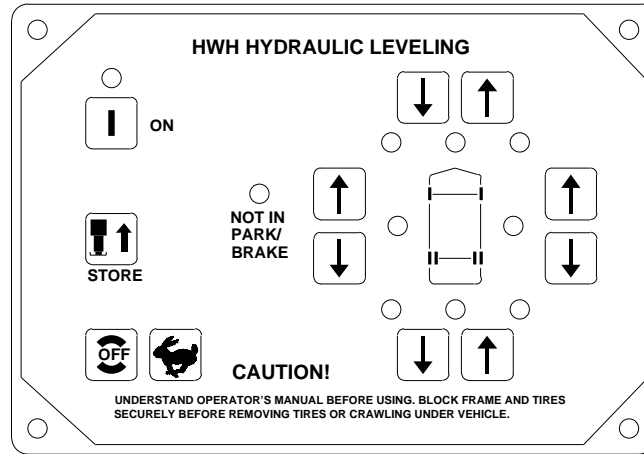

ELECTRICAL CONNECTION DIAGRAM

310 SERIES LEVELING SYSTEM (WITH PILOT AIR DUMP)

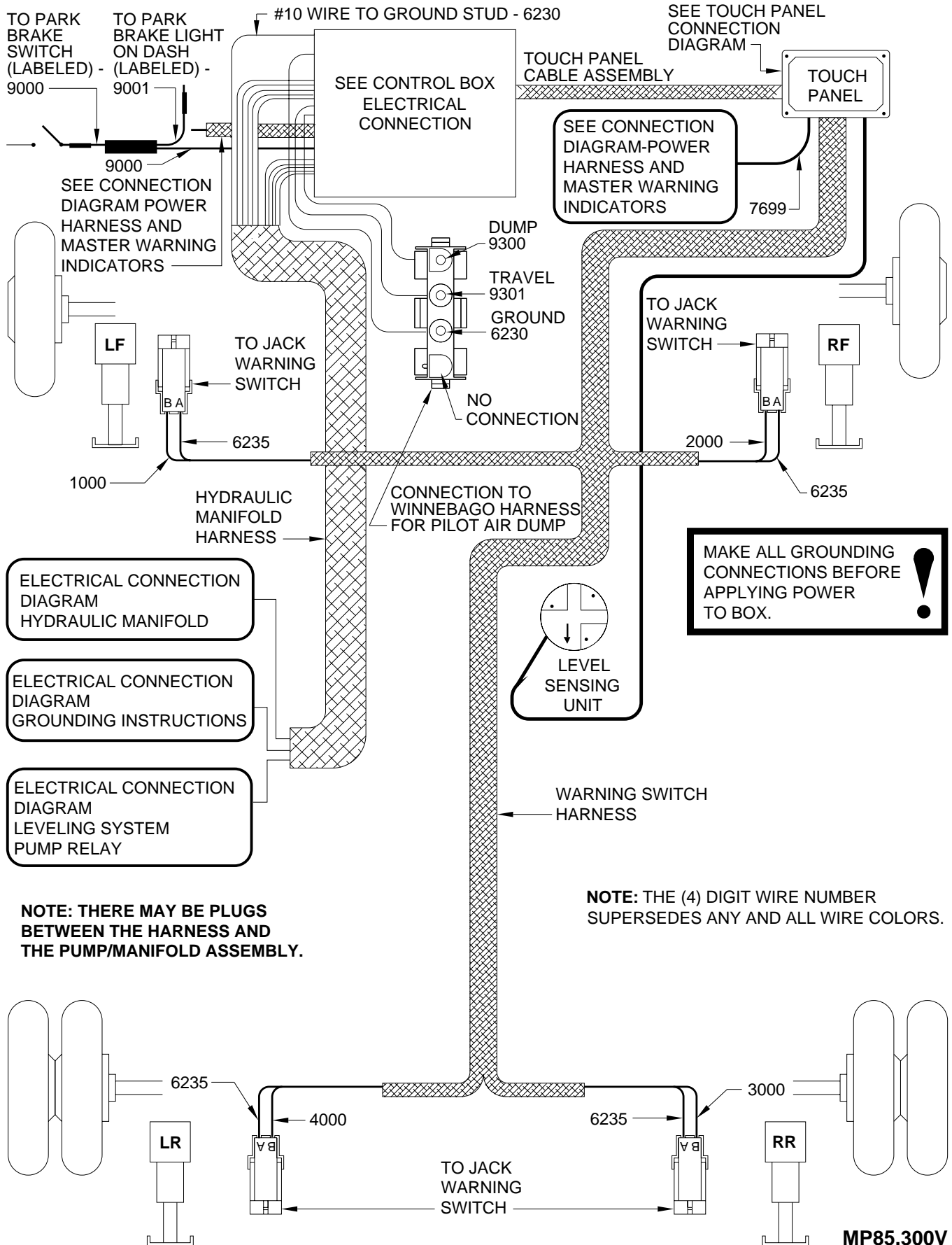

ELECTRICAL CONNECTION DIAGRAM ONE ROOM EXTENSION SYSTEM

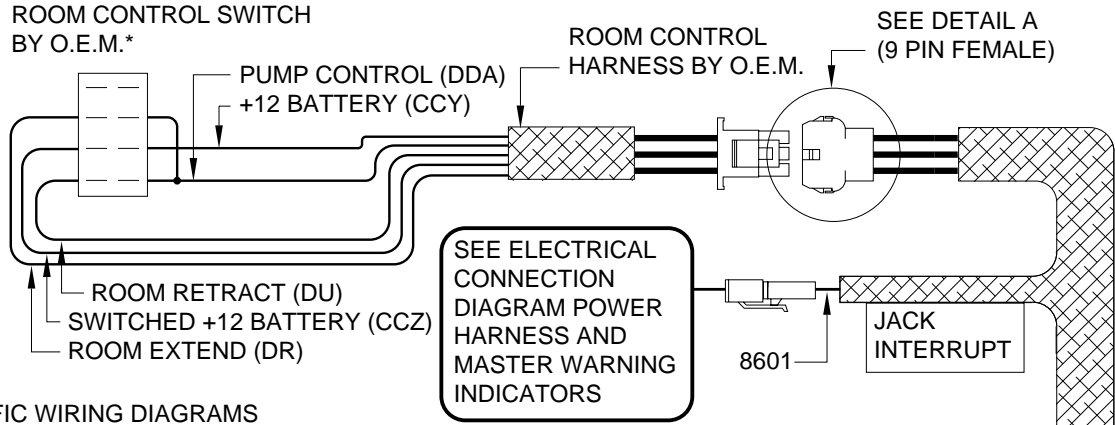

* FOR SPECIFIC WIRING DIAGRAMS AND INFORMATION CONTACT VEHICLE MANUFACTURER

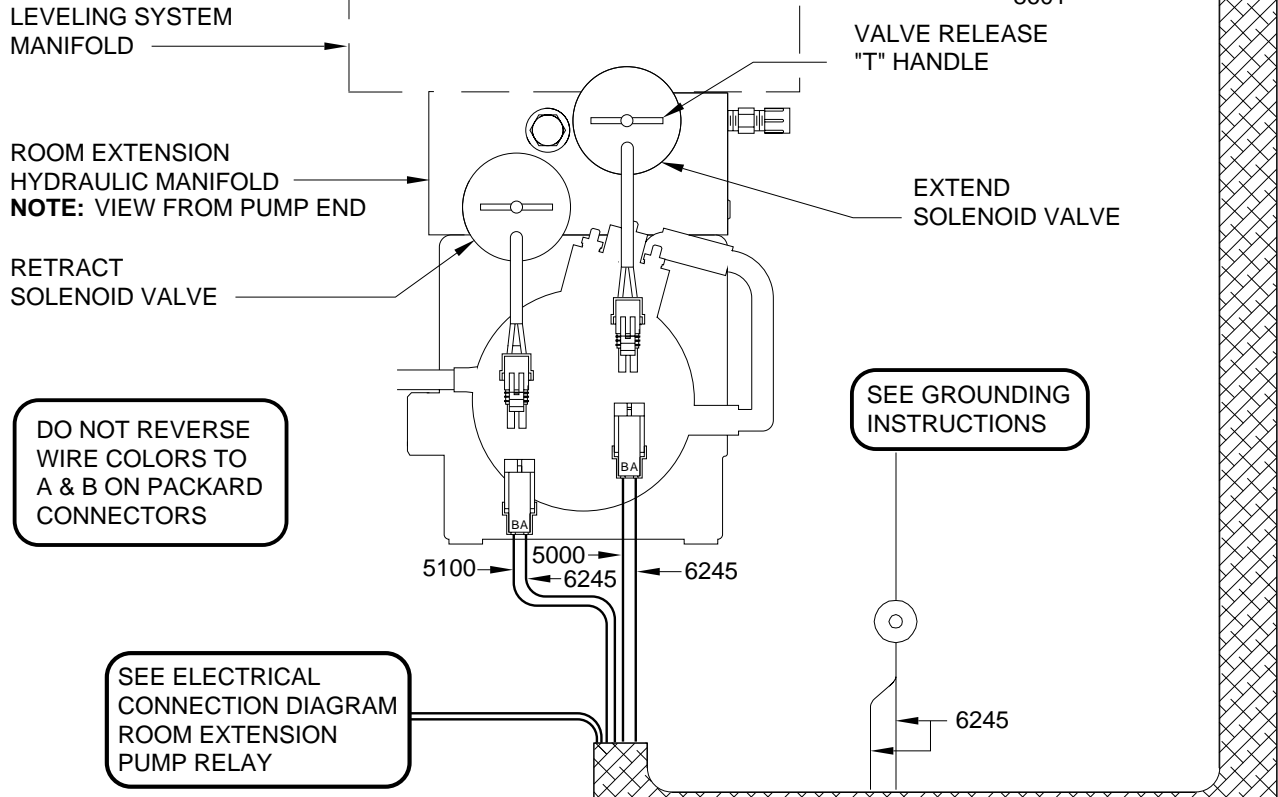
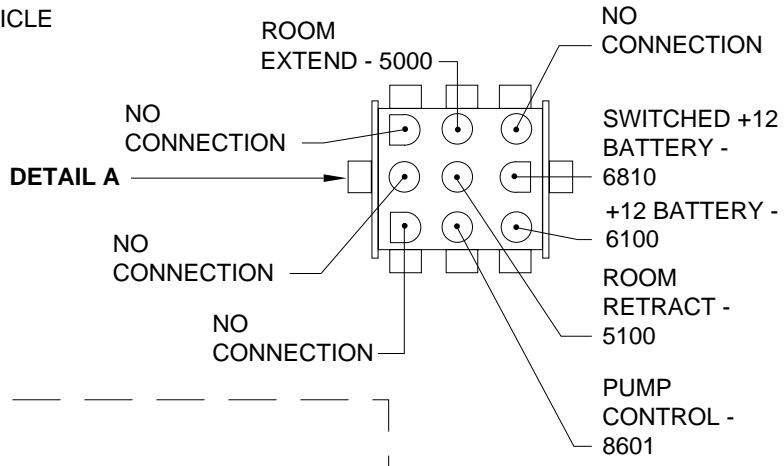

NOTE: THERE MAY BE PLUGS BETWEEN THE HARNESS AND THE PUMP/MANIFOLD ASSEMBLY.

VIEW FROM PUMP END

ELECTRICAL CONNECTION DIAGRAM HYDRAULIC MANIFOLD 310 SERIES LEVELING SYSTEM (WITH ROOM EXTENSION)

MANIFOLD DIAGRAM

VIEW FROM TOP

SEE GROUNDING
INSTRUCTION DIAGRAM

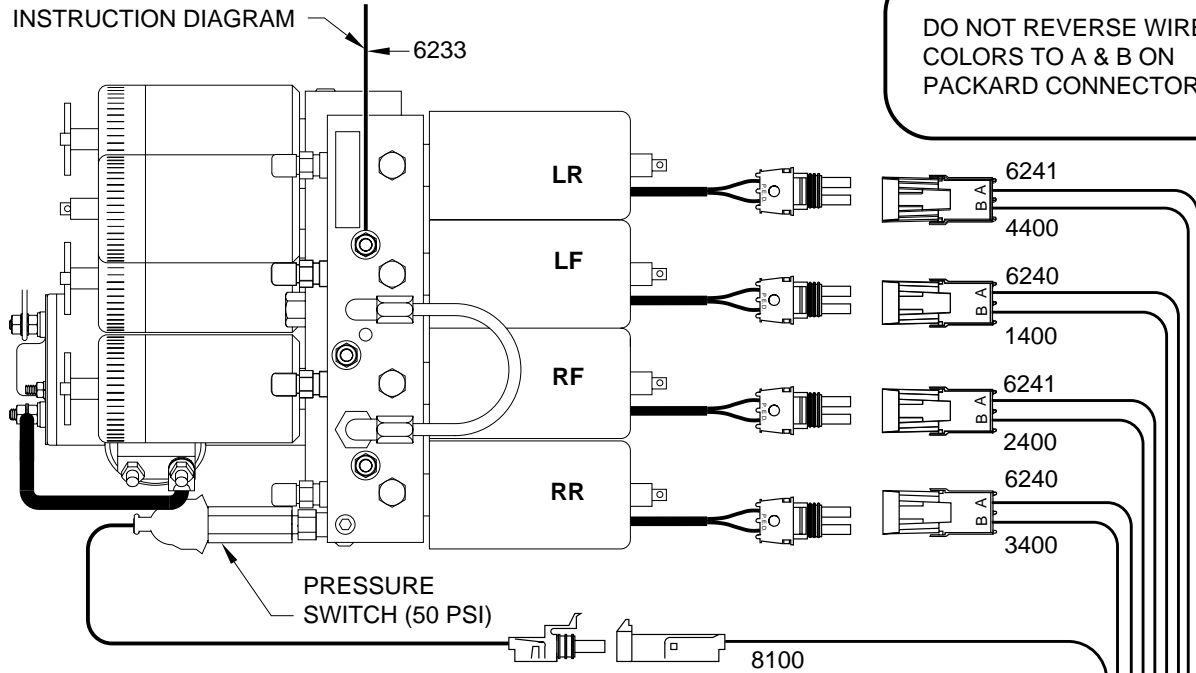

NOTE: THE (4) DIGIT WIRE NUMBER
SUPERSEDES ANY AND ALL WIRE COLORS.

LEVELING SYSTEM PUMP/MANIFOLD HARNESS

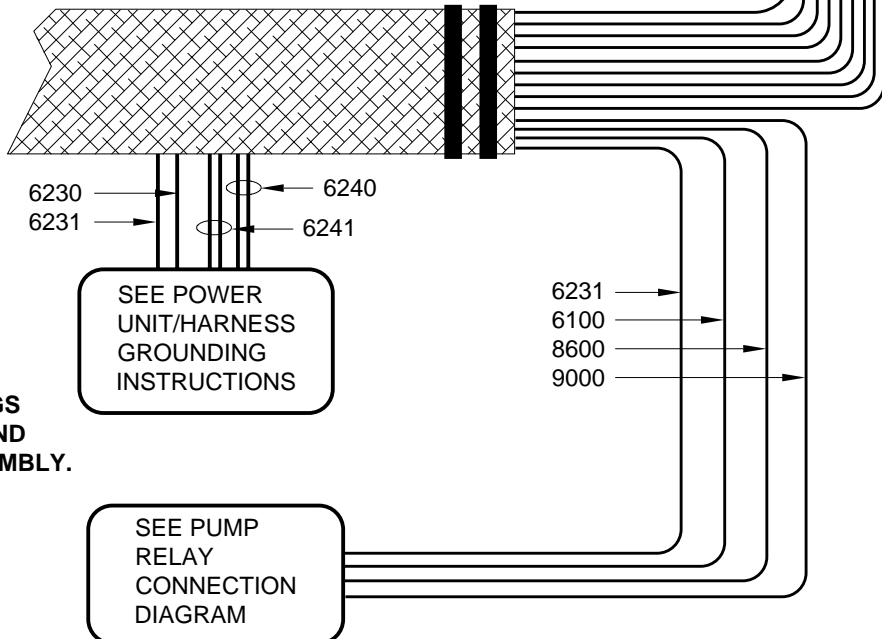

NOTE: THERE MAY BE PLUGS
BETWEEN THE HARNESS AND
THE PUMP/MANIFOLD ASSEMBLY.

ELECTRICAL CONNECTION DIAGRAM

310 SERIES LEVELING SYSTEM WITH ROOM EXTENSIONS

POWER HARNESS AND MASTER WARNING INDICATORS

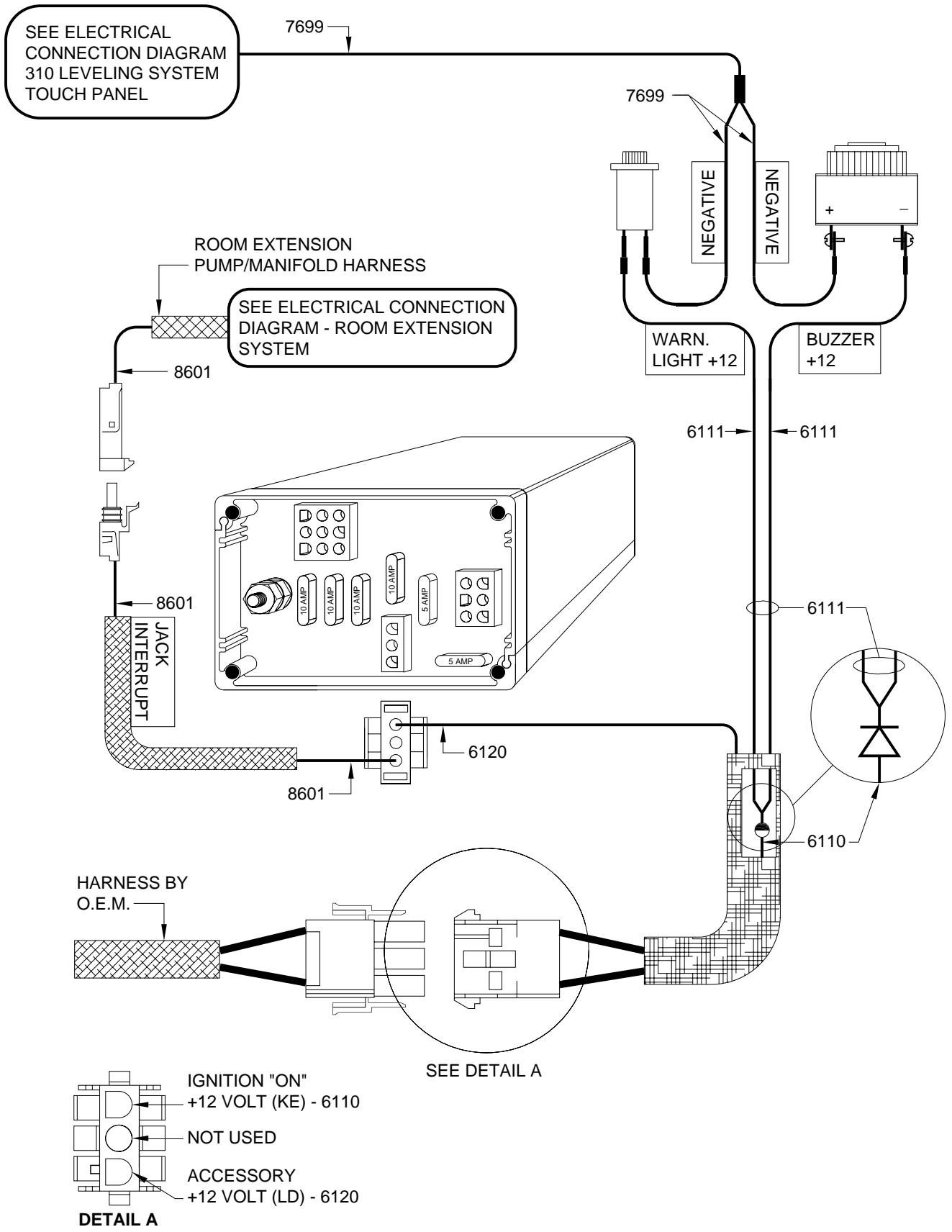

ELECTRICAL CONNECTION DIAGRAM

PUMP RELAYS

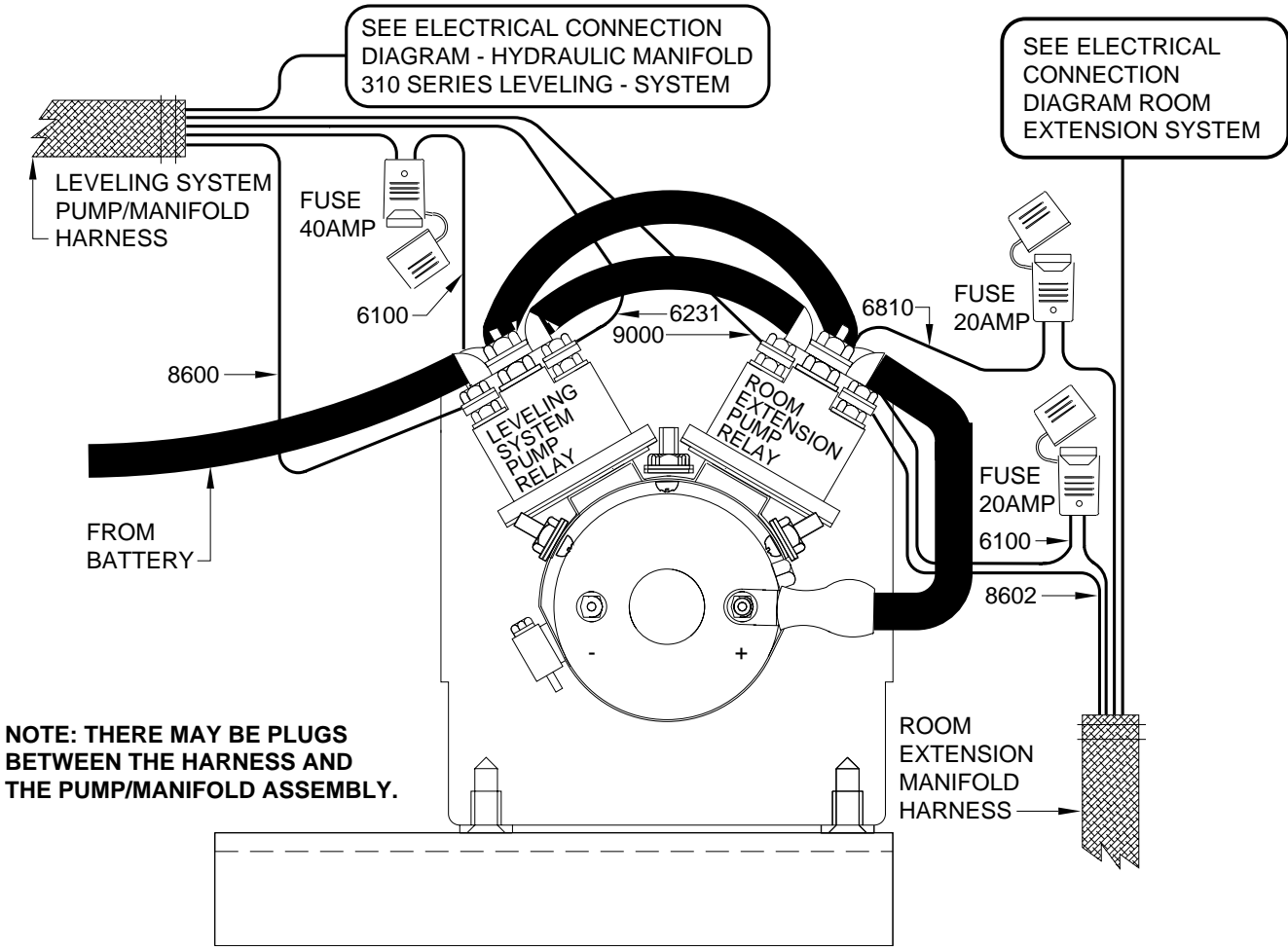
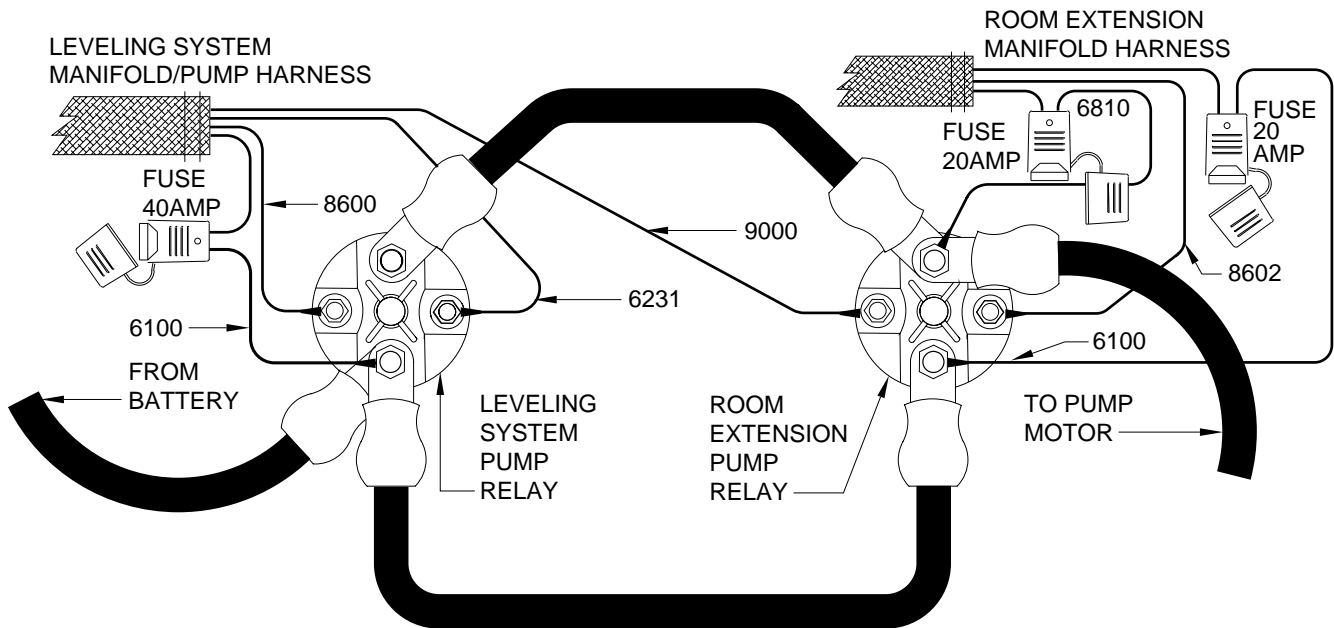

ELECTRICAL CONNECTION DIAGRAM

POWER UNIT/MANIFOLD PIGTAIL ASSEMBLY

WITH 1 ROOM EXTENSION

COACHES BEFORE MID - YEAR 2000 DID NOT HAVE THE PIGTAIL ASSEMBLY. REFER TO THE DIAGRAMS IN THIS MANUAL FOR CORRECT INFORMATION. COACHES BUILT AFTER MID - YEAR 2000 MAY HAVE THE PIGTAIL ASSEMBLY. COMPONENT CONNECTIONS WILL REMAIN THE SAME. THIS PAGE SHOWS THE PLUG CONNECTIONS FOR THE MAIN HARNESSSES.

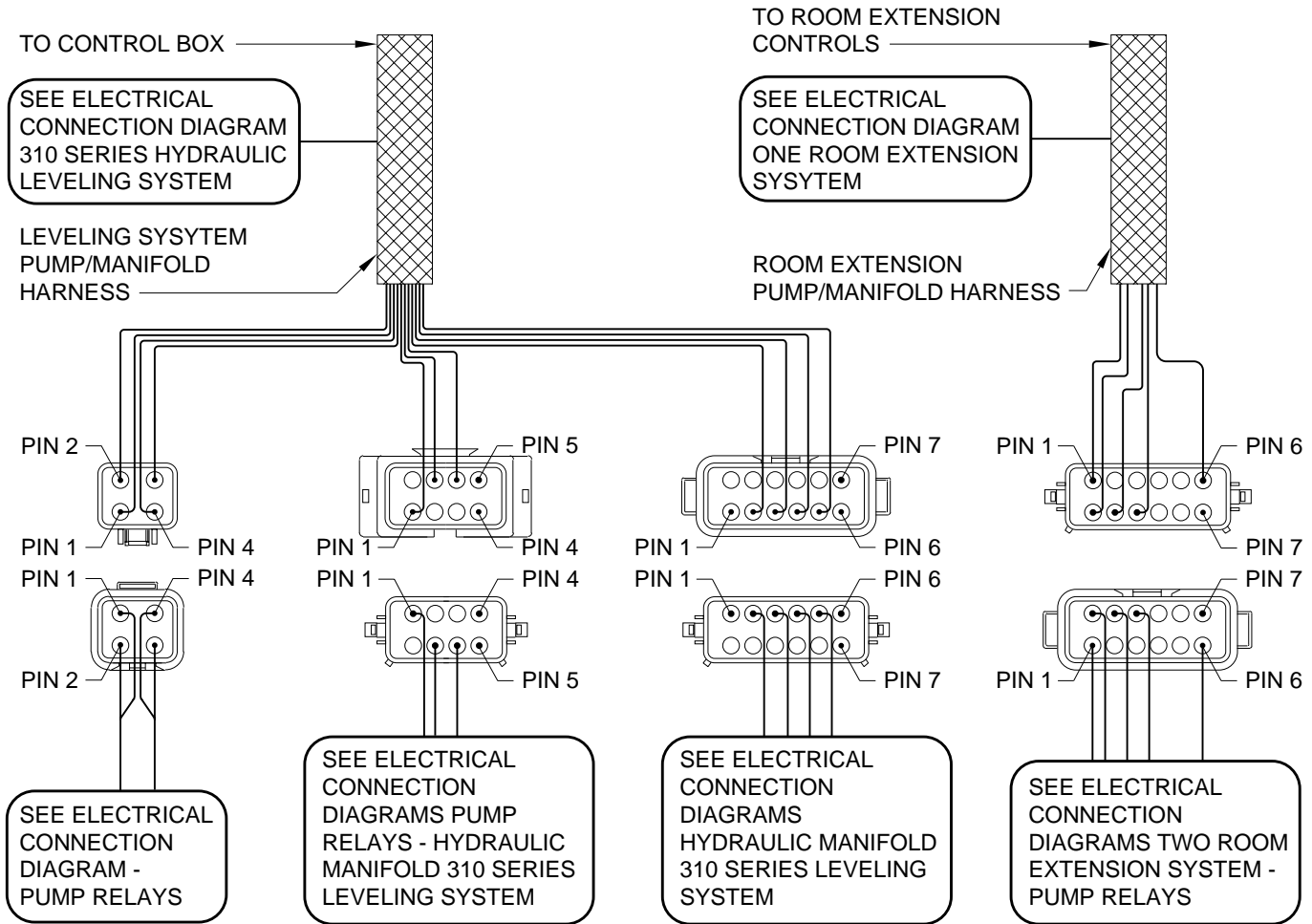

PIN 1 - 6100
+12 BATTERY

PIN 2 - 6100
+12 BATTERY

PIN 3 - 6230
GROUND

PIN 4 - 6230
GROUND

PIN 1 - 8600 LEVELING
SYSTEM PUMP RELAY

PIN 2 THRU 5 - N.C.

PIN 6 - 8100 MANIFOLD
PRESSURE SWITCH

PIN 7 - 9000 GROUND
FROM PARK BRAKE

PIN 8 - N.C.

PIN 1 - N.C.

PIN 2 - 4400
LR SOL. VALVE

PIN 3 - 2400
RF SOL. VALVE

PIN 4 - 1400
LF SOL. VALVE

PIN 5 - 3400
RR SOL. VALVE

PIN 6 THRU 12 - N.C.

PIN 1 - 8602 ROOM 1
PUMP CONTROL

PIN 2 THRU 5 - N.C.

PIN 6 - 6810 SWITCHED
BATTERY

PIN 7 THRU 9 - N.C.

PIN 10 - 5100 ROOM 1
RETRACT

PIN 11 - 5000 ROOM 1
EXTEND

PIN 12 - 6101
+12 BATTERY

GROUNDING INSTRUCTIONS POWER UNIT/HARNESS

310/325 SERIES, TOUCH PANEL-CONTROLLED LEVELING SYSTEM

WELDED PUMP MOUNT

USE GROUNDING STUD AND 3/8" EXTERNAL STAR LOCKWASHERS AS SHOWN.

IMPORTANT: 3/8" STAR LOCKWASHERS MUST BE USED BETWEEN GROUNDING SURFACE AND WIRE TERMINALS.

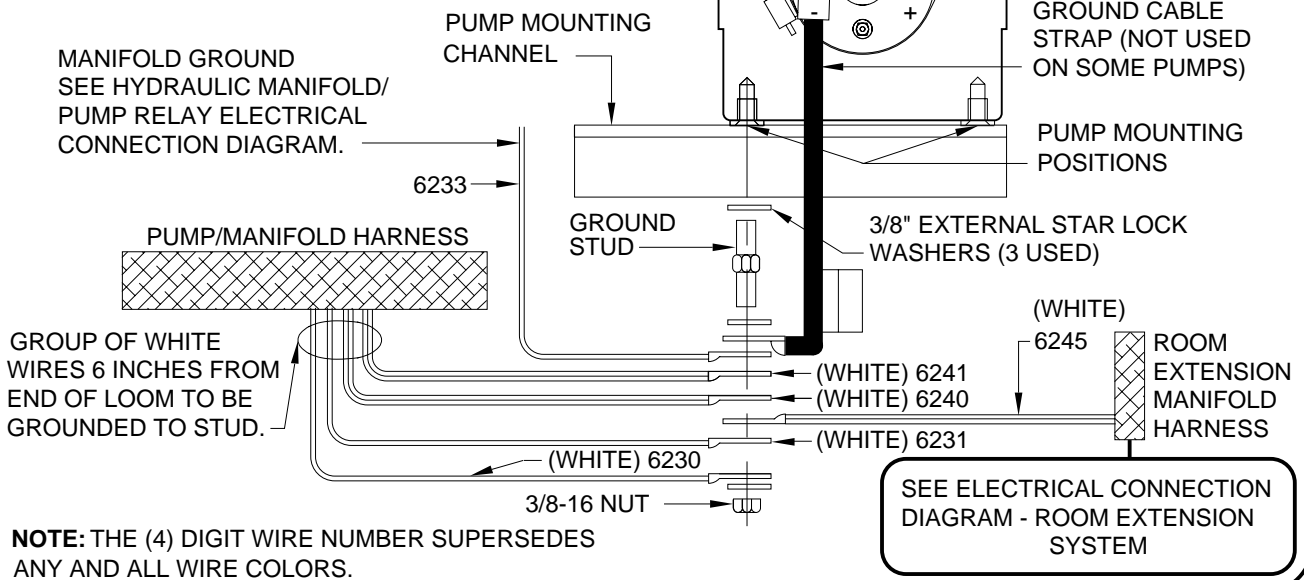

NOTE: THE (4) DIGIT WIRE NUMBER SUPERSEDES ANY AND ALL WIRE COLORS.

PUMP MOUNTED REMOTE FROM FRAME

USE GROUNDING STUD AND 3/8" EXTERNAL STAR LOCKWASHERS AS SHOWN.

IMPORTANT: 3/8" STAR LOCKWASHERS MUST BE USED BETWEEN GROUNDING SURFACE AND WIRE TERMINALS.

NOTE: THE (4) DIGIT WIRE NUMBER SUPERSEDES ANY AND ALL WIRE COLORS.

