



OPERATOR'S MANUAL

HWH® JOYSTICK-CONTROLLED 200 SERIES LEVELING SYSTEM and SPACEMAKER® ROOM EXTENSION SYSTEM

FEATURING:

Joystick BI-AXIS® Leveling Control

Hydraulic Leveling

Straight-Acting Jacks

Suspension Air Dump

Dual Cylinder Room Extension (With Rack Sensing Valve) or

"Vertical Arm" Room Extension (With Synchronizing Cylinder)

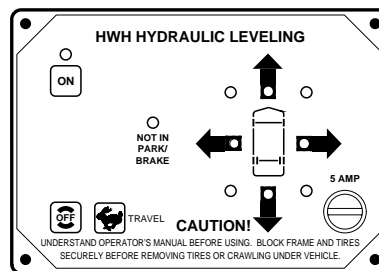
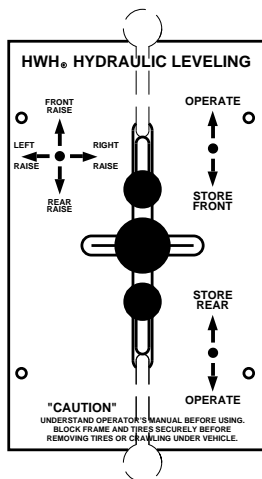

HWH CORPORATION

(On I-80, Exit 267 South)

2096 Moscow Road | Moscow, Iowa 52760

Ph: 800/321-3494 (or) 563/724-3396 | Fax: 563/724-3408

www.hwh.com

OPERATOR'S MANUAL

CAUTION!

READ THE ENTIRE OPERATOR'S MANUAL BEFORE OPERATING.

BLOCK FRAME AND TIRES SECURELY BEFORE CRAWLING UNDER VEHICLE. DO NOT USE LEVELING JACKS OR AIR SUSPENSION TO SUPPORT VEHICLE WHILE UNDER VEHICLE OR CHANGING TIRES. VEHICLE MAY DROP AND/OR MOVE FORWARD OR BACKWARD WITHOUT WARNING CAUSING INJURY OR DEATH.

KEEP ALL PEOPLE CLEAR OF VEHICLE WHILE LEVELING SYSTEM AND ROOM EXTENSION ARE BEING OPERATED. KEEP PEOPLE AND OBSTRUCTIONS CLEAR OF ROOM WHEN OPERATING.

NEVER PLACE HANDS OR OTHER PARTS OF THE BODY NEAR HYDRAULIC LEAKS. OIL MAY PENETRATE SKIN CAUSING INJURY OR DEATH.

WEAR SAFETY GLASSES WHEN INSPECTING OR SERVICING THE SYSTEM TO PROTECT EYES FROM DIRT, METAL CHIPS, OIL LEAKS, ETC. FOLLOW ALL OTHER APPLICABLE SHOP SAFETY PRACTICES.

IF THIS VEHICLE IS EQUIPPED WITH KICK-DOWN STYLE JACKS, DO NOT OVER EXTEND THE REAR JACKS. IF THE VEHICLE IS REMOVED FROM ONE OR BOTH REAR WHEELS, THE VEHICLE MAY ROLL FORWARD OR BACKWARD, OFF THE JACKS.

NOTE: KEEP THE CONTROL VALVE LEVERS IN THE STORE POSITION WHEN JACKS ARE NOT IN USE.

IMPORTANT: IF VEHICLE IS EQUIPPED WITH A ROOM EXTENSION, READ ROOM EXTENSION SECTION BEFORE OPERATING LEVELING SYSTEM.

HOW TO OBTAIN WARRANTY SERVICE

THIS IS NOT TO BE INTERPRETED AS A STATEMENT OF WARRANTY

HWH CORPORATION strives to maintain the highest level of customer satisfaction. Therefore, if you discover a defect or problem, please do the following:

FIRST: Notify the dealership where you purchased the vehicle or had the leveling system installed. Dealership management people are in the best position to resolve the problem quickly. If the dealer has difficulty solving the problem, he should immediately contact the Customer Service Department, at HWH CORPORATION.

SECOND: If your dealer cannot or will not solve the problem, notify the Customer Service Department:
HWH CORPORATION 2096 Moscow Rd. Moscow IA. 52760
(563) 724-3396 OR (800) 321-3494. Give your name and address, coach manufacturer and model year, date the coach was purchased, or the date of system installation,

description of the problem, and where you can be reached during business hours (8:00 a.m. till 5:00 p.m. c.s.t.). HWH CORPORATION personnel will contact you to determine whether or not your claim is valid. If it is, HWH CORPORATION will authorize repair or replacement of the defective part, either by appointment at the factory or by the authorization of an independent service facility, to be determined by HWH CORPORATION. All warranty repairs must be performed by an independent service facility authorized by HWH CORPORATION, or at the HWH CORPORATION factory, unless prior written approval has been obtained from proper HWH CORPORATION personnel.

CONTROL IDENTIFICATION

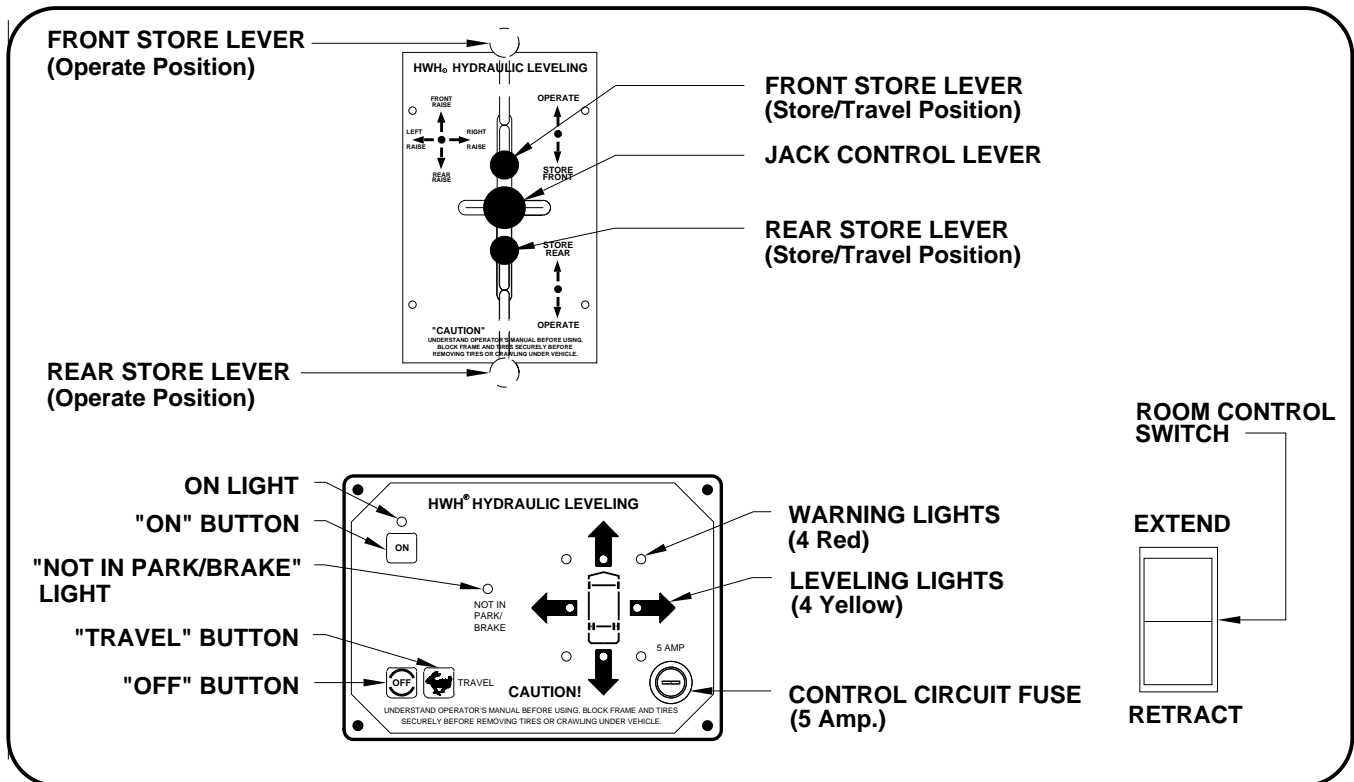

CONTROL FUNCTIONS

CONTROLS

"ON" BUTTON: This button provides control power to operate the electrical relay on the pump, the LEVELING LIGHTS, the WARNING LIGHTS, and the POWER ON LIGHT. It does not control power to the "JACKS DOWN" LIGHT or the WARNING BUZZER. The ignition switch controls power to these.

"TRAVEL" BUTTON: This button returns the air suspension to the travel mode. Panel shuts off when travel button is pushed.

"OFF" BUTTON: This button turns off control power to the leveling and room extension systems.

STORE LEVERS: These two levers are used to retract the jacks into the STORE/TRAVEL position for travel. They must be in the "OPERATE" position for leveling.

JACK CONTROL LEVER: Jacks are extended in pairs by pushing the jack control lever to one of the "RAISE" positions. This movement of the lever activates the pump and directs hydraulic fluid to the jacks. When the lever is released it will return to the neutral (center) position, turning off the pump and stopping jacks in position.

ROOM CONTROL SWITCH: This is a momentary switch. It will extend or retract the room while the switch is pressed. The POWER ON LIGHT and a WARNING LIGHT must be lit to operate the room.

INDICATORS

ON LIGHT: This light indicates the system is on.

"NOT IN PARK/BRAKE" LIGHT: This light illuminates when the "ON" button is pushed and the parking brake has not been applied. The system will not turn on.

LEVELING LIGHTS: A yellow LEVELING LIGHT indicates the side or end of the coach is low. When the vehicle is level all the LEVELING LIGHTS will be out.

WARNING LIGHT: A red WARNING LIGHT indicates the jacks that have extended two inches or more. A WARNING LIGHT illuminates when its corresponding jack is extended at least two inches and the POWER ON LIGHT is illuminated.

WARNING BUZZER: A buzzer will sound if a jack is extended two inches or more and the ignition switch is ON.

"MASTER JACKS DOWN" LIGHT: This light will illuminate when any jack is extended two inches or more and the ignition switch is on.

OPERATING PROCEDURES

SITE SELECTION

Maintain adequate clearance in all directions for vehicle, room extensions, awnings, doors, steps, etc. Vehicle may move in any direction due to jacks extending or retracting, settling of jacks or vehicle, equipment malfunction, etc.

Blocks or pads should be placed under the leveling jacks when used on soft ground or asphalt paving.

LEVELING AND STABILIZING PROCEDURE

IMPORTANT: Do not operate the room extension without first leveling and stabilizing vehicle.

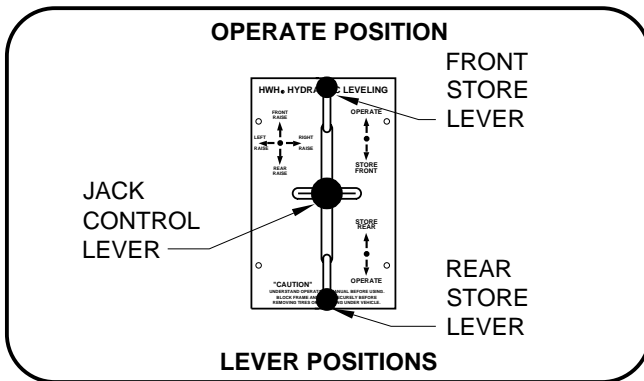

1. Place transmission gear selector in its parking position, apply parking brake, and securely block tires.

2. Turn the ignition switch to ACCESSORY.

3. Press the "ON" BUTTON. The POWER ON LIGHT will illuminate. The system will begin to dump air from the vehicle suspension.

NOTE: If the parking brake is not applied the "NOT IN PARK/ BRAKE" LIGHT will illuminate while the "ON" BUTTON is pressed. The system will not operate if the park brake is off.

NOTE: If the park brake is released and the ignition is in "ON" or "ACC" the vehicle can return to ride height.

4. Place blocks or pads under jacks when used on soft ground or asphalt paving.

5. Move the FRONT STORE LEVER and REAR STORE LEVER to their "OPERATE" POSITIONS.

6. Jacks are extended in pairs by moving the JACK CONTROL LEVER to one of the "RAISE" POSITIONS ("FRONT RAISE", "REAR RAISE", "LEFT RAISE", OR "RIGHT RAISE"). When a jack extends two inches or more its corresponding WARNING LIGHT illuminates. An illuminated LEVELING LIGHT indicates the side or end of the vehicle that is low. Extend jacks in pairs accordingly until all LEVELING LIGHTS are out. If the ground is too uneven the jacks may not have enough stroke to level the vehicle. The vehicle may have to be moved.

7. Stabilize the vehicle by extending any jacks that are not touching the ground. To extend the remaining jacks move the JACK CONTROL LEVER to the "FRONT RAISE" or "REAR RAISE" position. Do not use the "LEFT RAISE" or "RIGHT RAISE" positions for stabilizing.

8. If the room is to be extended omit Steps 10 and 11. Move on to the ROOM EXTEND PROCEDURE.

9. Press the "OFF" BUTTON to turn the system off.

10. Turn the ignition switch off.

OPERATING PROCEDURES

ROOM EXTEND PROCEDURE

CAUTION: OPERATING THE ROOM WITH ANY ROOM-LOCKING DEVICES LOCKED OR THE MANUAL-RETRACT WINCH ATTACHED CAN CAUSE PERSONAL INJURY AND VEHICLE DAMAGE. IT IS THE OPERATOR'S RESPONSIBILITY TO ENSURE THAT ALL ROOM-LOCKING DEVICES AND THE MANUAL-RETRACT WINCH ARE DISENGAGED BEFORE OPERATING THE ROOM.

IMPORTANT: It is not recommended to extend or retract any jacks when the room is extended.

IMPORTANT: It is recommended to level and stabilize the vehicle before extending the room.

1. Follow the LEVELING AND STABILIZING PROCEDURE.
2. Unlock all room-locking devices.

NOTE: If the MANUAL RETRACT WINCH is attached to the room remove it before extending the room.

CAUTION: KEEP PEOPLE AND OBSTRUCTIONS CLEAR OF ROOM WHEN OPERATING.

NOTE: Make sure there is adequate clearance to fully extend the room.

3. Turn the ignition switch to ACCESSORY.
4. Press the "ON" BUTTON if the POWER ON LIGHT is not illuminated.

NOTE: To operate the room, the POWER ON LIGHT and a WARNING LIGHT must be illuminated.

5. To extend the room, press and hold the ROOM CONTROL SWITCH in the "EXTEND" position until the room is fully extended.

NOTE: Hold the switch to "EXTEND" three or four seconds after the room is fully extended. This assures proper pressurization of the cylinders. **During normal operation of the room, do not reverse direction of the room until the room is fully extended. If necessary, the direction of the room may be reversed, but watch for binding of the room. If the direction of the room has been reversed, DO NOT re-extend the room until the room has been fully retracted.**

IMPORTANT: Do not hold the ROOM CONTROL SWITCH in the "EXTEND" position for more than ten seconds after the room is fully extended or stops moving. **If either side of the room stops moving, release the room control switch immediately. DO NOT force the room. DO NOT reverse direction of the room, contact HWH Customer Service for assistance 1-800-321-3494.**

NOTE: Releasing the ROOM CONTROL SWITCH will halt the operation of the room.

6. Press the "OFF" BUTTON.
7. Turn off the ignition switch.

IMPORTANT: Do not use a room extension support when the vehicle is supported by the leveling system.

OPERATING PROCEDURES

ROOM RETRACT PROCEDURE

CAUTION: KEEP PEOPLE AND OBSTRUCTIONS CLEAR OF ROOM WHEN OPERATING.

IMPORTANT: It is not recommended to extend or retract any leveling jacks when the room is extended.

1. Turn the ignition switch to ACCESSORY.
2. Press the "ON" BUTTON.

NOTE: To operate the room, the POWER ON LIGHT and a WARNING LIGHT must be illuminated.

3. To retract the room press and hold the ROOM CONTROL SWITCH in the "RETRACT" position until the room is fully retracted.

NOTE: Hold the switch to "RETRACT" three or four seconds after the room is fully retracted. This assures proper pressurization of the cylinders. **During normal operation of the room, do not reverse direction of the room until the room is fully retracted. If necessary, the direction of the room may be reversed, but watch for binding of the room. If the direction of the room has been reversed, DO NOT retract the room until the room has been fully extended.**

IMPORTANT: Do not hold the ROOM CONTROL SWITCH in the "RETRACT" position for more than ten seconds after the room is fully retracted or stops moving. **If either side of the room stops moving, release the room control switch immediately. DO NOT force the room. DO NOT reverse direction of the room, contact HWH Customer Service for assistance 1-800-321-3494.**

NOTE: Releasing the ROOM CONTROL SWITCH will halt the operation of the room.

4. Press the "OFF" Button.
5. Turn the ignition switch off.
6. Engage all room-locking devices.
7. If the room will not retract see the MANUAL ROOM RETRACT PROCEDURE.

IMPORTANT: Room-locking devices should be locked while traveling.

OPERATING PROCEDURES

LEVELING SYSTEM RETRACT PROCEDURE

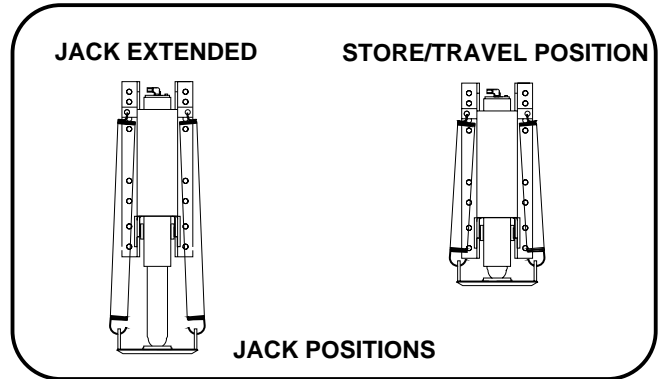
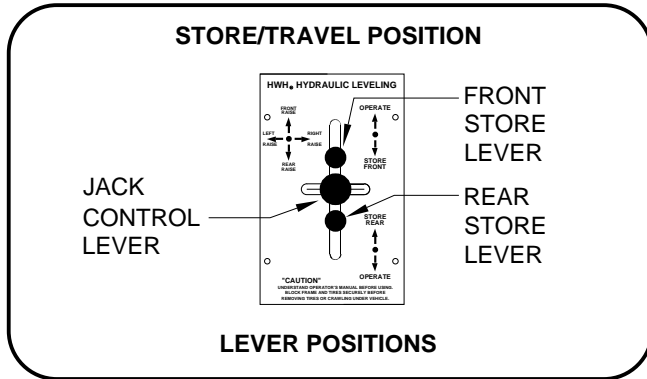

IMPORTANT: Do not retract the jacks while the room is extended.

CAUTION: MAKE SURE THAT PEOPLE AND EQUIPMENT ARE CLEAR OF THE VEHICLE.

1. Start the vehicle's engine.

IMPORTANT: Always retract the front jacks first.

2. To retract the jacks move the FRONT STORE LEVER then the REAR STORE LEVER to the STORE/TRAVEL POSITION.

CAUTION: THE STORE LEVERS SHOULD BE KEPT IN THE "STORE" POSITION WHILE TRAVELING TO KEEP THE JACKS IN THE STORE/TRAVEL POSITION.

3. Visually check that each jack is in its STORE/TRAVEL POSITION.

4. Push the "TRAVEL" button. This will allow the vehicle to return to ride height.

NOTE: The leveling system panel does not have to be on. If the panel is on, pushing the "TRAVEL" button will turn the panel off.

CAUTION: DO NOT MOVE THE VEHICLE WHILE ANY JACKS ARE EXTENDED. THIS VEHICLE IS EQUIPPED WITH STRAIGHT-ACTING JACKS. MOVING THE VEHICLE WITH THE JACKS EXTENDED CAN CAUSE SEVERE DAMAGE TO THE JACKS AND THE VEHICLE AND CAN CREATE A DRIVING HAZARD. DO NOT RELY SOLELY UPON THE WARNING LIGHTS, THE "JACKS DOWN" LIGHT, OR THE WARNING BUZZER AS AN INDICATION THAT ALL THE JACKS ARE IN THE STORE/TRAVEL POSITION. IT IS THE OPERATOR'S RESPONSIBILITY TO VISUALLY CHECK THAT ALL JACKS ARE FULLY RETRACTED TO THE STORE/TRAVEL POSITION.

5. Press the "OFF" BUTTON.

6. Turn the ignition switch OFF or proceed to travel.

NOTE: If the ignition is in the "ON" or "ACC" position and the park brake is released, the Dump/Travel valve will be in the travel position.

CAUTION: DO NOT MOVE THE VEHICLE UNLESS THE VEHICLE IS AT THE PROPER RIDE HEIGHT. IS IS THE OPERATOR'S RESPONSIBILITY TO VISUALLY CHECK THAT THE VEHICLE HAS RETURNED TO RIDE HEIGHT.

NOTE: If the vehicle is parked or stored with the jacks extended for an extended period of time and the jacks fail to retract completely, extend the jacks back down to the ground then retract the jacks again.

MANUAL ROOM RETRACT PROCEDURE (WITH SOLENOID VALVES WITH VALVE RELEASE "T" HANDLES)

(USE ONLY WHEN THE ROOM WILL NOT RETRACT WITH THE ROOM CONTROL SWITCH)

OVERVIEW

The room can be retracted manually if a hydraulic or electrical failure prevents the room from being retracted using the ROOM CONTROL SWITCH. For normal retract sequence see the ROOM RETRACT PROCEDURE.

CAUTION: THE MANUAL RETRACT WINCH IS EQUIPPED FOR MANUALLY RETRACTING THE ROOM ONLY. IT IS NOT TO BE USED FOR LIFTING OR ANY OTHER APPLICATION. HIGH FORCES ARE CREATED WHEN USING A WINCH, CREATING POTENTIAL SAFETY HAZARDS. FAILURE TO FOLLOW ALL CAUTIONS AND INSTRUCTIONS MAY CAUSE FAILURE OF THE MANUAL RETRACT WINCH OR CONNECTIONS RESULTING IN DAMAGE OR PERSONAL INJURY. MAINTAIN FIRM GRIP ON THE WINCH HANDLE AT ALL TIMES. NEVER RELEASE THE HANDLE WHEN RATCHET LEVER IS IN THE OFF POSITION AND THE WINCH IS LOADED. THE WINCH HANDLE COULD SPIN VIOLENTLY AND CAUSE PERSONAL INJURY. CHECK THE WINCH AND STRAPS FOR DAMAGE OR WEAR, AND CHECK FOR PROPER RATCHET OPERATION ON EACH USE OF THE WINCH. DO NOT USE IF DAMAGED OR WORN.

1. Retract jacks following the LEVELING SYSTEM RETRACT PROCEDURE.

NOTE : When manually retracting the room, make sure the jacks are retracted before retracting the room.

2. Locate the HYDRAULIC PUMP/MANIFOLD unit.

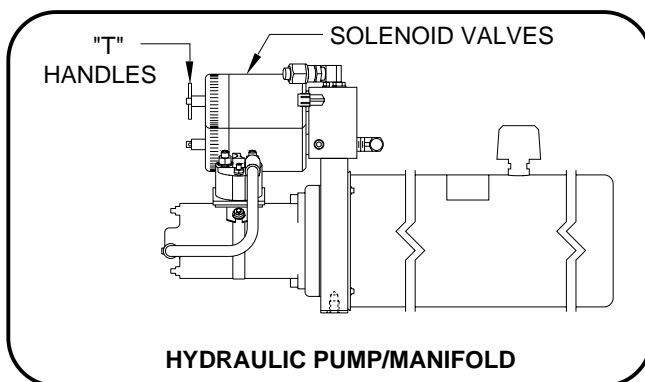

3. Open the SOLENOID VALVES by turning the "T" HANDLES counterclockwise.

NOTE : The "T" HANDLE may turn easily at first but will become more difficult to turn as an internal spring is compressed. Be sure to open both valves completely (about six turns of "T" HANDLE).

NOTE : The room may move slightly as the SOLENOID VALVES are opened and internal pressure is released.

4. Locate the MANUAL RETRACT WINCH and connect it to the room according to the vehicle manufacturer's instructions. To extend the WINCH STRAP firmly grasp WINCH HANDLE, place RATCHET LEVER in its OFF position, and slowly rotate the WINCH HANDLE counterclockwise, keeping a firm grip on the handle. When enough WINCH STRAP is extended, place the RATCHET LEVER in its ON position and slowly rotate the WINCH HANDLE clockwise until the RATCHET LEVER locks.

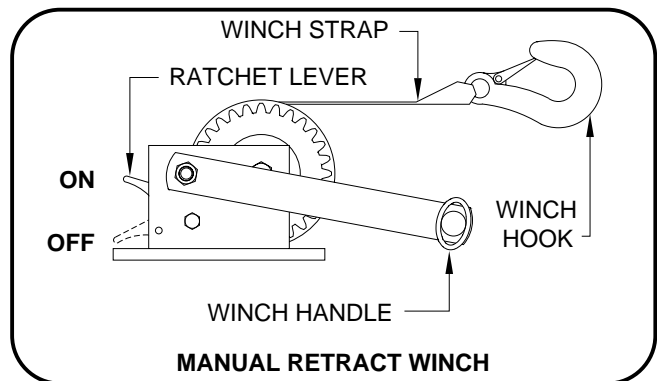

5. Slowly winch the room in by turning the WINCH HANDLE clockwise. The RATCHET LEVER should produce a loud, sharp, clicking noise.

NOTE : Winching the room in quickly will raise pressure in the hydraulic fluid and make winching more difficult.

CAUTION: OPERATE THE MANUAL RETRACT WINCH BY HAND POWER ONLY. IF THE WINCH CANNOT BE CRANKED EASILY WITH ONE HAND IT IS PROBABLY OVERLOADED. IF WINCHING BECOMES TOO DIFFICULT STOP AND CHECK FOR OBSTRUCTIONS OR RESTRICTIONS ON THE ROOM AND ROOM EXTENSION MECHANISM.

6. When the room is fully retracted, engage the room locking devices. Leave the retract winch in place.

CAUTION: THE ROOM EXTENSION SOLENOID VALVE "T" HANDLES MUST BE IN THE OPEN POSITION WHEN THE MANUAL RETRACT WINCH IS ENGAGED.

7. The system should be repaired before using again.

MAINTENANCE

OIL LEVEL

It is important that the four jacks and any HWH rooms are fully retracted before checking the hydraulic oil level. To check the oil supply, remove the breather cap from the top of the hydraulic oil reservoir. The oil level should be approximately one inch below the top of the reservoir when adequately filled.

FLUID: HWH Specialty Hydraulic Oil is recommended. In an emergency Dexron automatic transmission fluid can be used.

NOTE: Dexron automatic transmission fluid contains red dye and can cause staining should a leak occur. **DO NOT USE** brake fluid or hydraulic jack fluid. Use of these can damage seals.

UNUSUAL CONDITIONS

If driving conditions are unusually muddy, the jacks may become caked or clogged with mud. This condition may hamper the proper operation of the leveling system. This problem may be prevented or remedied by cleaning off each jack if they become excessively muddy. In wet or icy weather the jacks may become encrusted with ice. This may cause

the leveling system to function improperly. To eliminate this problem, periodically check the jacks and break loose any ice which may be causing improper operation.

NOTE: All major components of the system can be replaced with rebuilt parts or can be sent to HWH CORPORATION to be rebuilt, when the system is out of warranty.

LEVEL SENSING UNIT ADJUSTMENT

Level the vehicle by placing a circular bubble level in the center of the freezer floor or location within the vehicle that is to be level. With the vehicle level, adjust the sensing unit until all yellow lights are off. This is done by drawing up the corresponding screw if the sensing unit is mounted below the surface as shown or backing out the corresponding screw if the sensing unit is mounted above the surface. Bump the sensing unit to see that it has settled down in the level position.

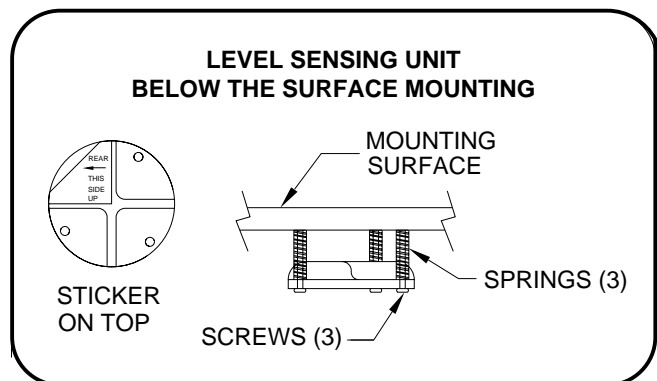

TROUBLE SHOOTING

The following is a list of problems, and possible solutions, which might occur to the leveling and room extension systems.

NOTE: Only qualified technicians should install or repair leveling and room extension systems. A knowledge of hydraulics, welding, and the vehicle's suspension and electrical systems is required. In addition, an understanding of the leveling and room extension systems' hydraulics and electronics is required.

1. JACK RETRACTS AFTER COACH IS LEVEL.

- A. Hose or jack has external leak.
- B. Fluid is leaking back to reservoir through the control valve.

2. JACKS WILL NOT RETRACT COMPLETELY.

- A. Jack clogged with mud or ice.
- B. Main rod bent or scored.
- C. Valve plunger is not completely depressed by valve handle.
- D. Spring weak or broken.
- E. Hydraulic line pinched.

3. IGNITION SWITCH IS ON, BUT NO POWER TO PUMP AND/OR LIGHTS.

- A. Park brake not set.
- B. 12 volts from power source not present.
- C. Faulty PC board.
- D. Faulty wire or electrical connection.

4. PUMP WILL NOT ACTIVATE.

- A. Grounding switch on valve not working.
- B. Pump relay not functioning.
- C. Pump not grounded.

5. HYDRAULIC PUMP ACTIVATES WITHOUT USE OF CONTROL VALVE HANDLES.

- A. Grounding switch at valve shorted.
- B. Pump relay stuck.
- C. Relay control wire shorted to ground.

6. HYDRAULIC PUMP ACTIVATES, BUT THE JACKS WILL NOT EXTEND.

- A. STORE LEVERS not in the "OPERATE" POSITION.
- B. Oil supply is low in reservoir.
- C. Pump is not developing pressure.
- D. Broken hydraulic line.

7. LEVELING LIGHTS (YELLOW) ARE NOT FUNCTIONING PROPERLY.

- A. Yellow lights will not go out when vehicle is level: adjust sensing unit.
- B. If two or more yellow lights are on replace PC board or check level sensing unit.

8. WARNING LIGHTS (RED) ARE NOT FUNCTIONING PROPERLY.

- A. Light will not come on: check for broken wire at warning switch on the jack.
- B. Lights will not go out: bad warning switch or wires are shorted to ground.
- C. Check PC board.

9. PANEL SHUTS OFF WHEN THE ROOM CONTROL SWITCH IS PRESSED.

- A. Engine battery is low.
- B. Bad BOSCH relay in the FUSED ACCESSORY CIRCUIT provided by Winnebago.
- C. Faulty wire or electrical connection.

10. PUMP RUNS BUT ROOM DOES NOT MOVE.

- A. Jacks not down.
- B. Bad BOSCH relay in the ROOM EXTENSION CIRCUIT provided by Winnebago.
- C. Faulty wire or electrical connection.

11. PUMP DOES NOT COME ON WHEN ROOM CONTROL SWITCH IS PRESSED.

- A. The panel is off.
- B. ROOM CONTROL SWITCH is faulty.
- C. Faulty wire or electrical connection.

12. ROOM CREEPS OUT AFTER CLOSED.

- A. EXTEND SOLENOID VALVE has an internal leak.
- B. FRONT OR REAR CYLINDER on room extension has an internal leak.

HYDRAULIC CONNECTION DIAGRAM BI-AXIS VALVE LEVELING SYSTEM WITH ROOM EXTENSION

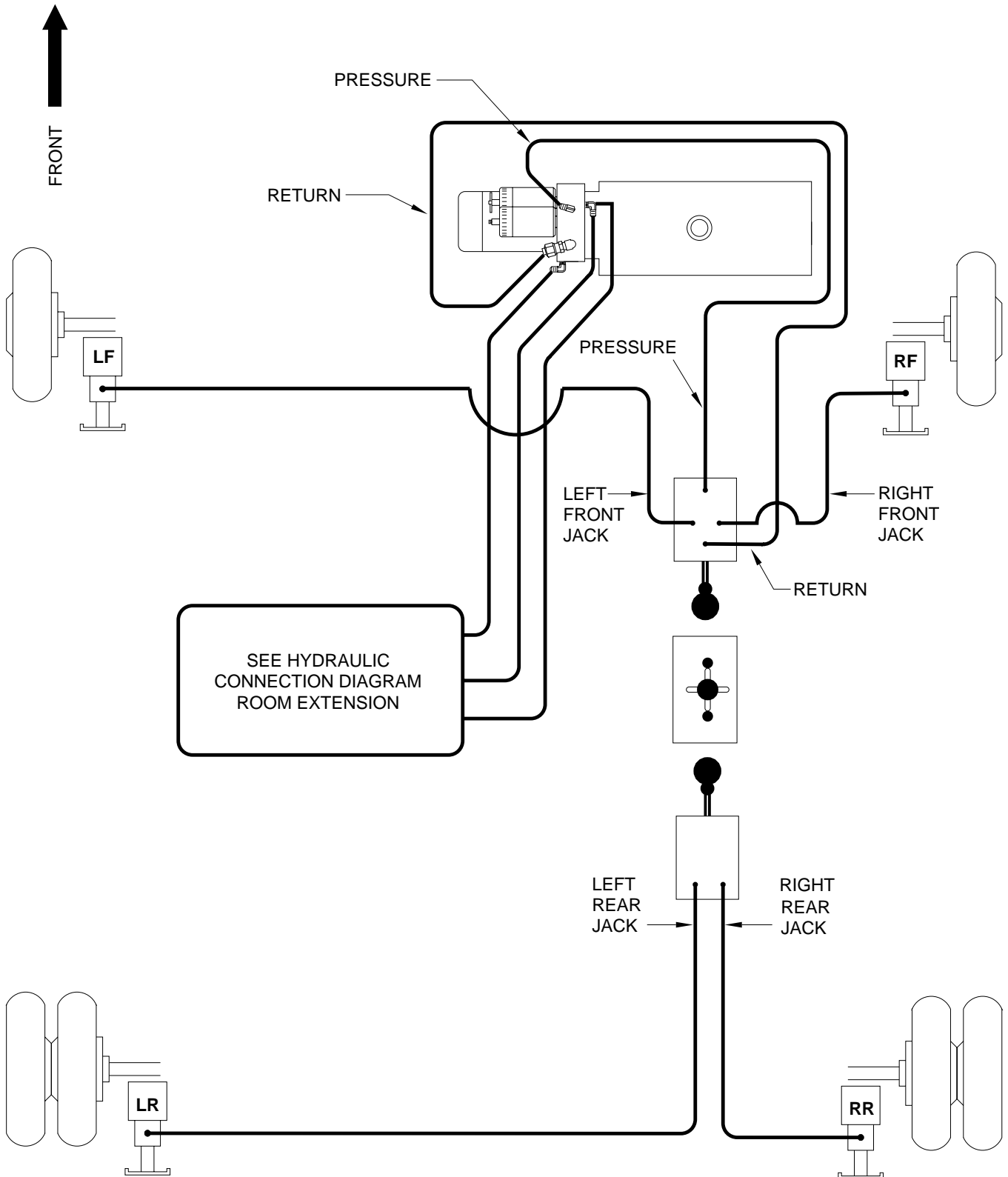

HYDRAULIC LINE CONNECTION DIAGRAM DUAL CYLINDER ROOM EXTENSION SYSTEM WITH RACK SENSING VALVE

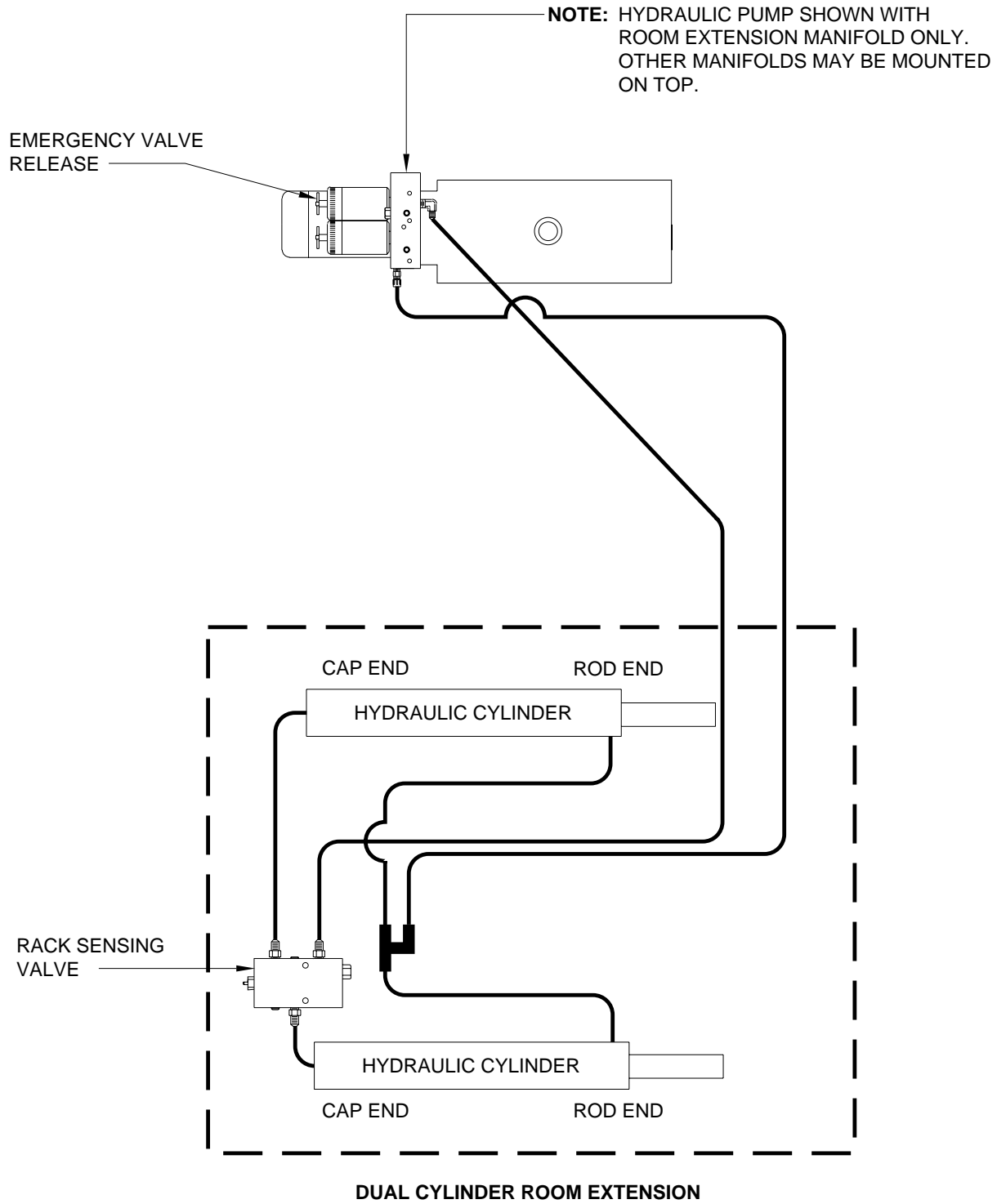

HYDRAULIC LINE CONNECTION DIAGRAM VERTICAL ARM ROOM EXTENSION WITH SYNCHRONIZING CYLINDER

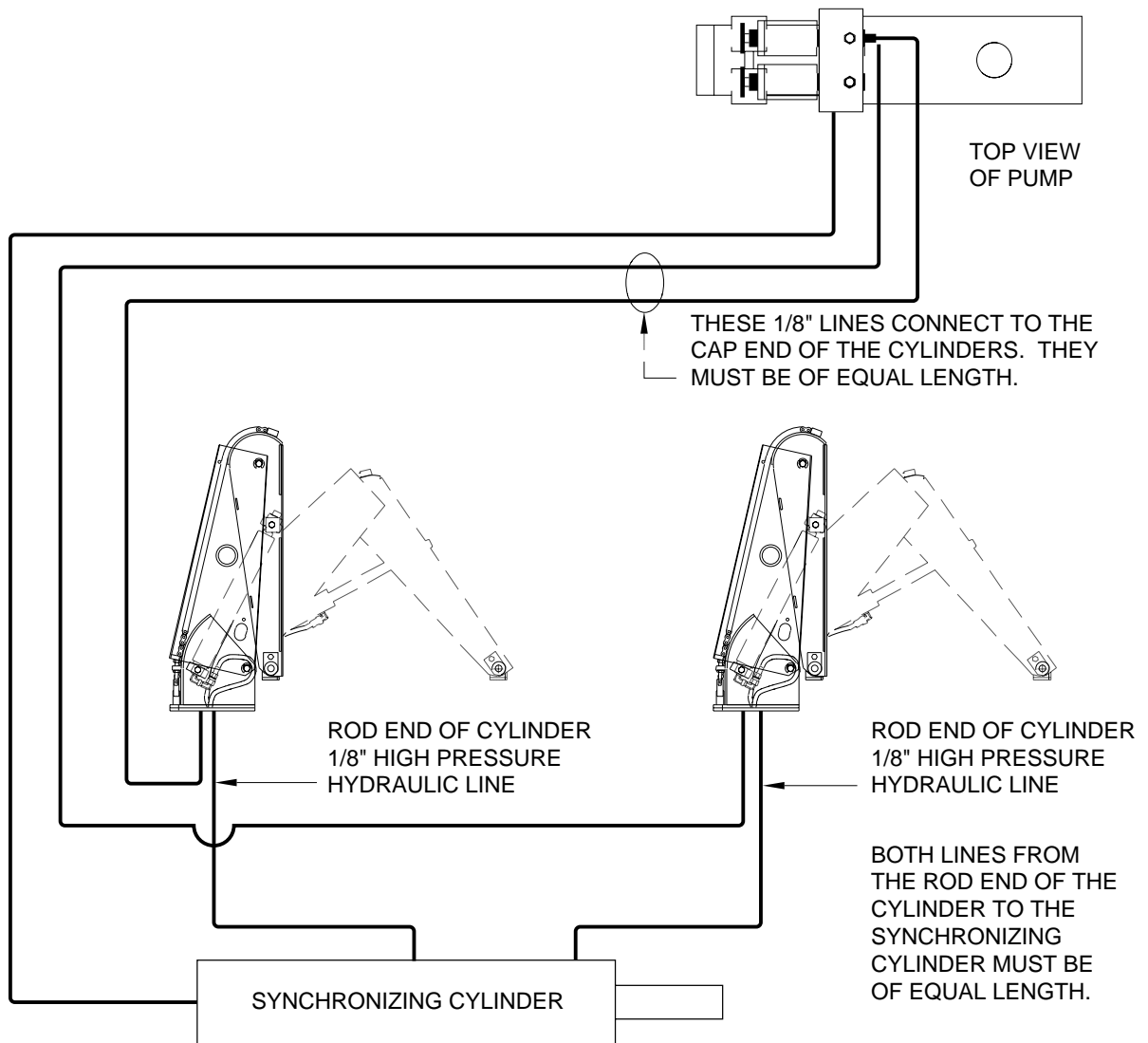

HYDRAULIC SCHEMATIC DIAGRAM DUAL CYLINDER ROOM EXTENSION SYSTEM W/RACK SENSING VALVE

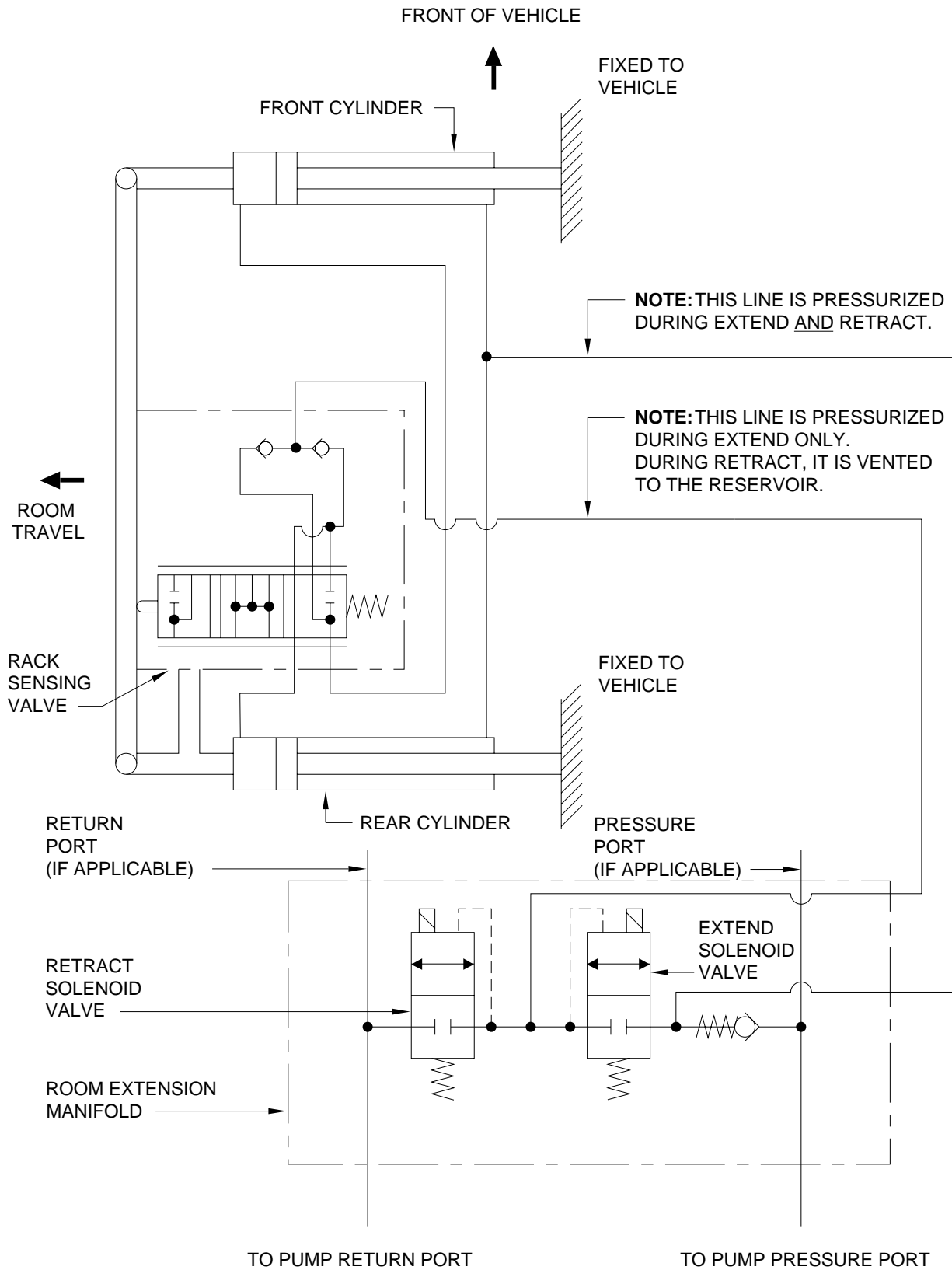

HYDRAULIC SCHEMATIC DIAGRAM
200/210/225 SERIES JOY STICK BI-AXIS LEVELING SYSTEM
WITH STRAIGHT-ACTING JACKS

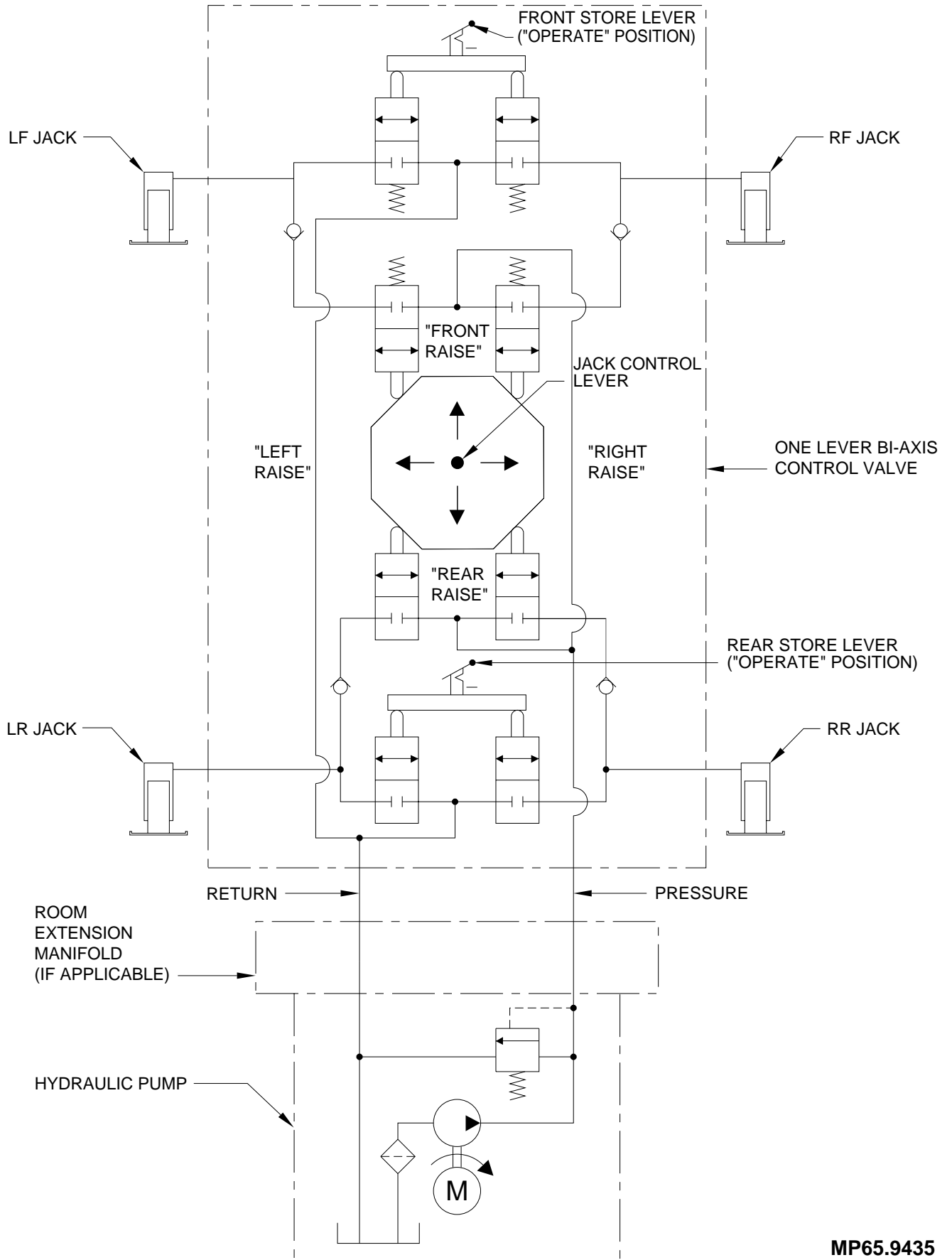

HYDRAULIC SCHEMATIC DIAGRAM VERTICAL ARM ROOM EXTENSION WITH SYNCHRONIZING CYLINDER

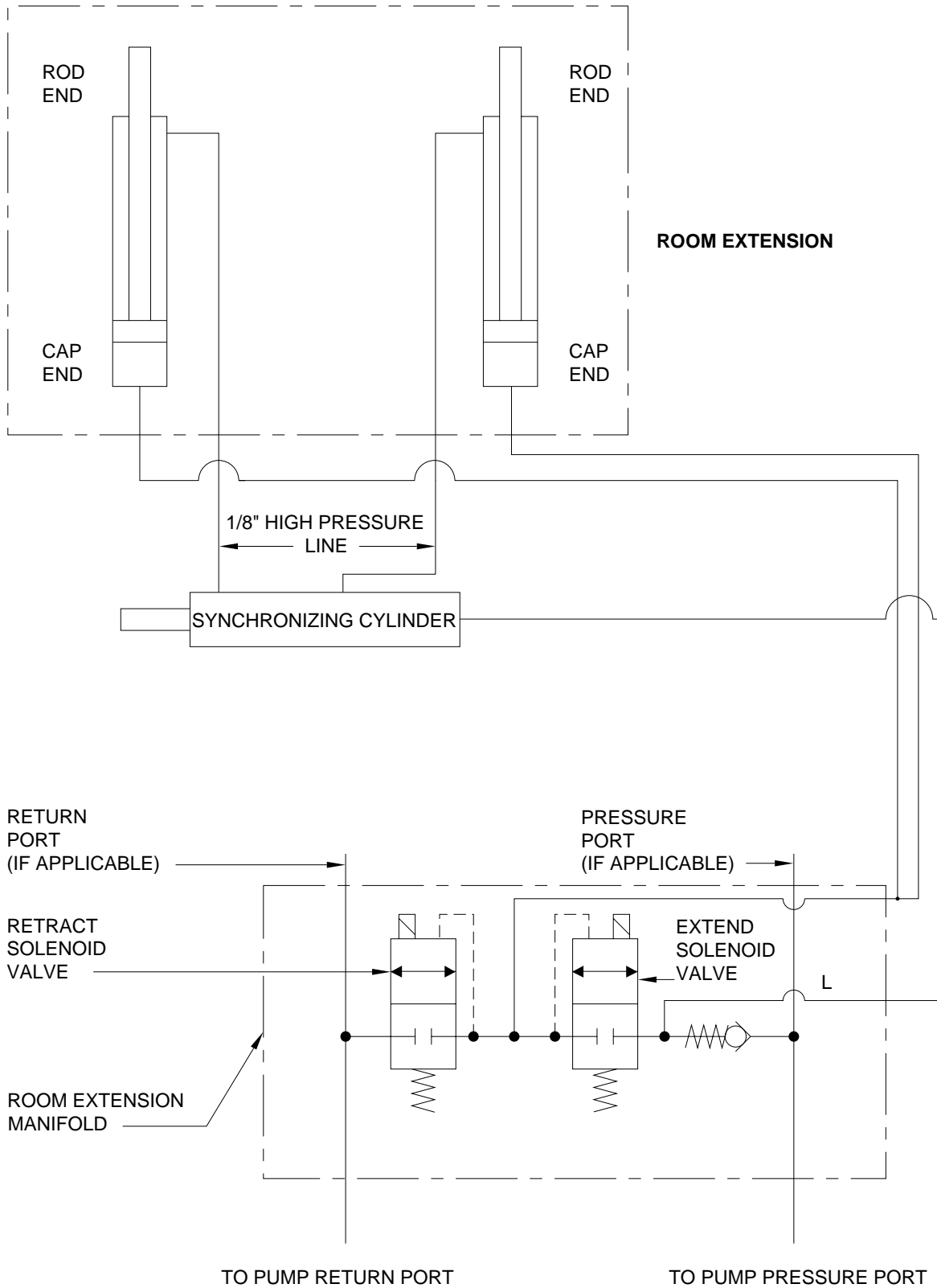

ELECTRICAL CONNECTION DIAGRAM

PILOT AIR DUMP

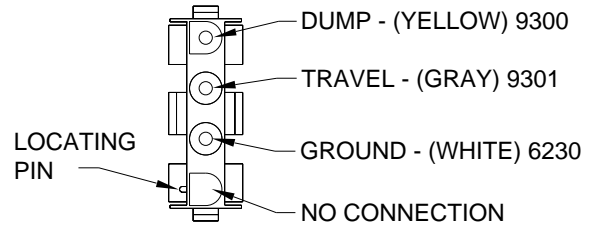
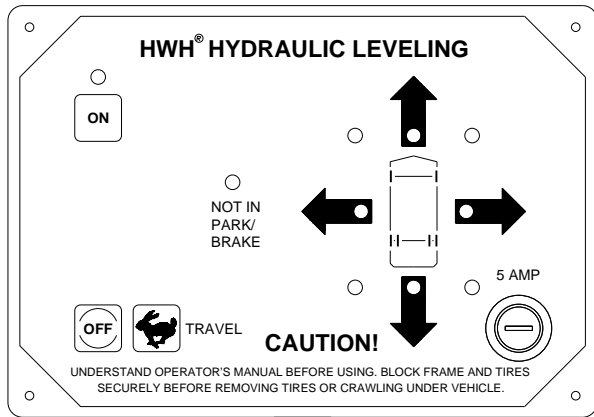

NOTE: THE (4) DIGIT WIRE NUMBER SUPERSEDES ANY AND ALL WIRE COLORS.

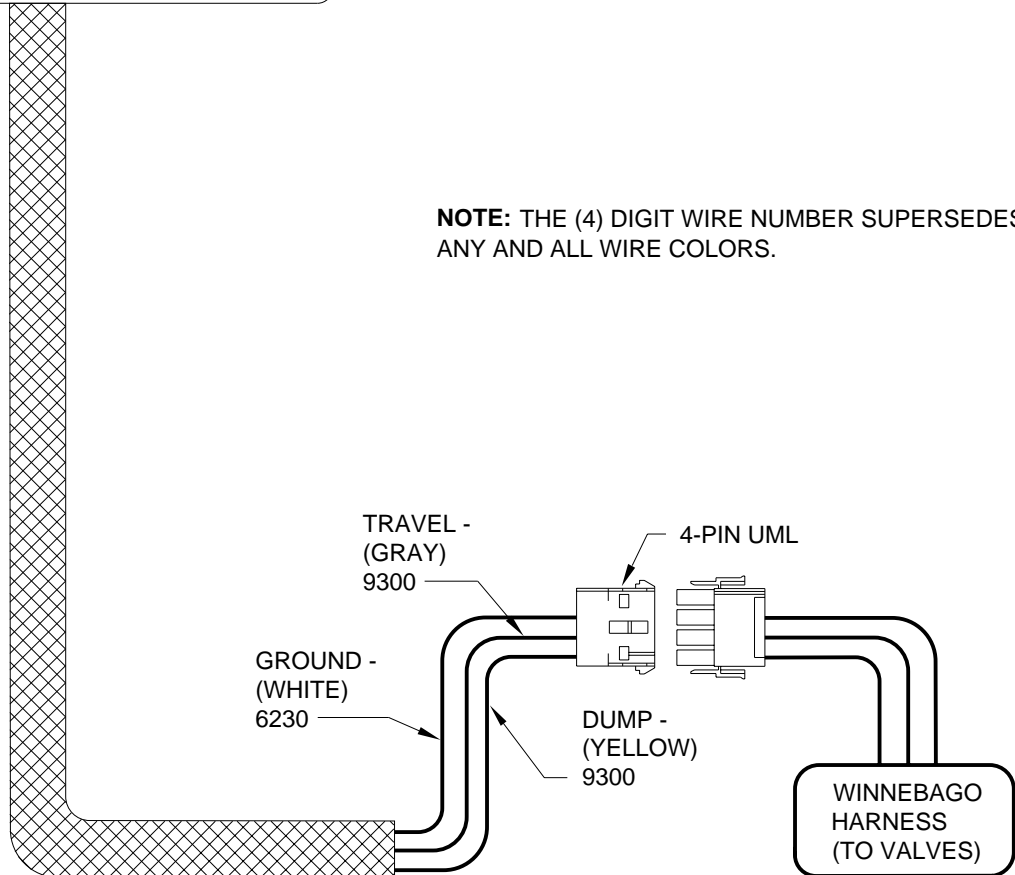

ELECTRICAL CONNECTION DIAGRAM BI-AXIS VALVE LEVELING SYSTEM (WITH ROOM EXTENSION)

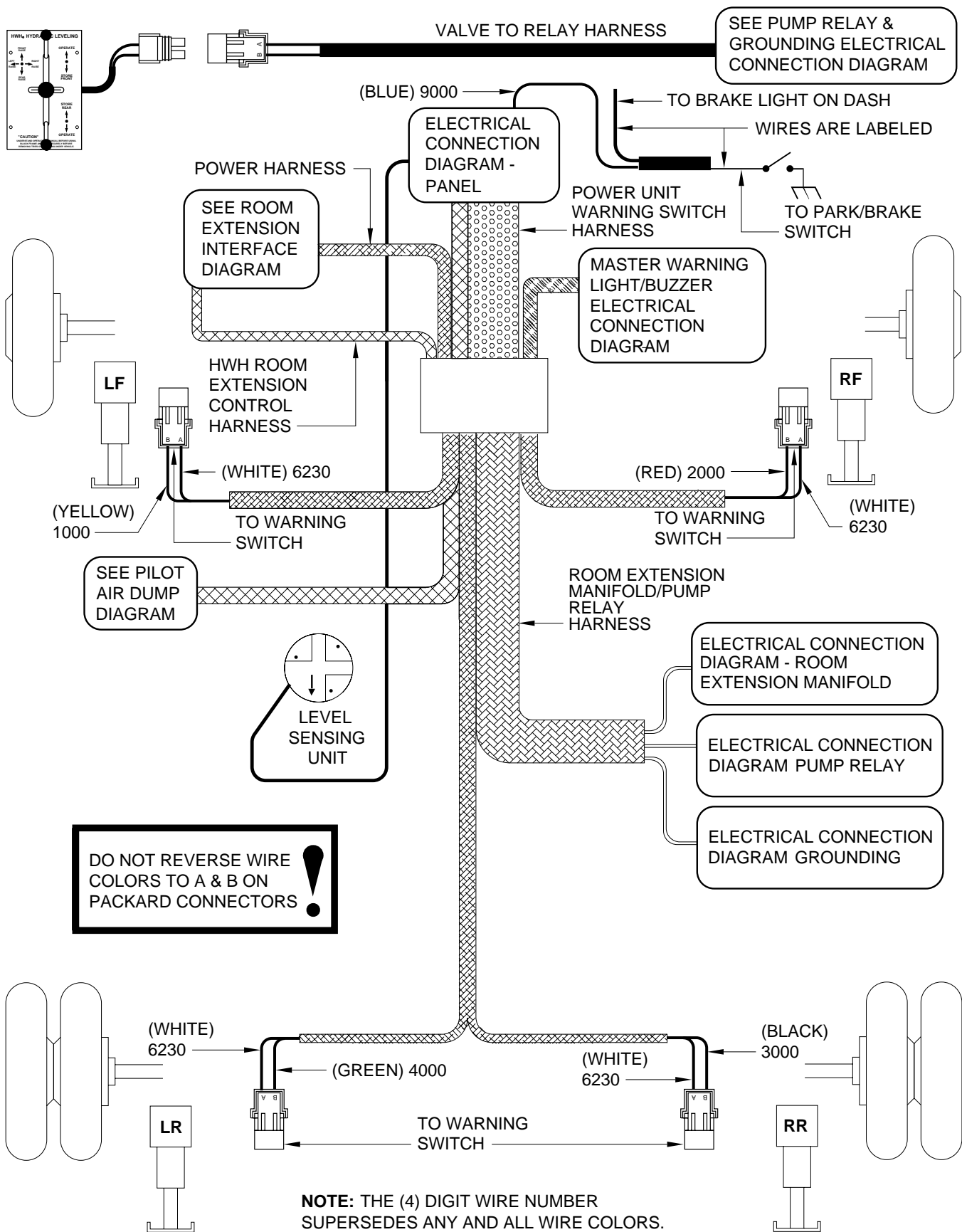

ELECTRICAL CONNECTION DIAGRAM BI - AXIS VALVE LEVELING SYSTEM ROOM EXTENSIONS

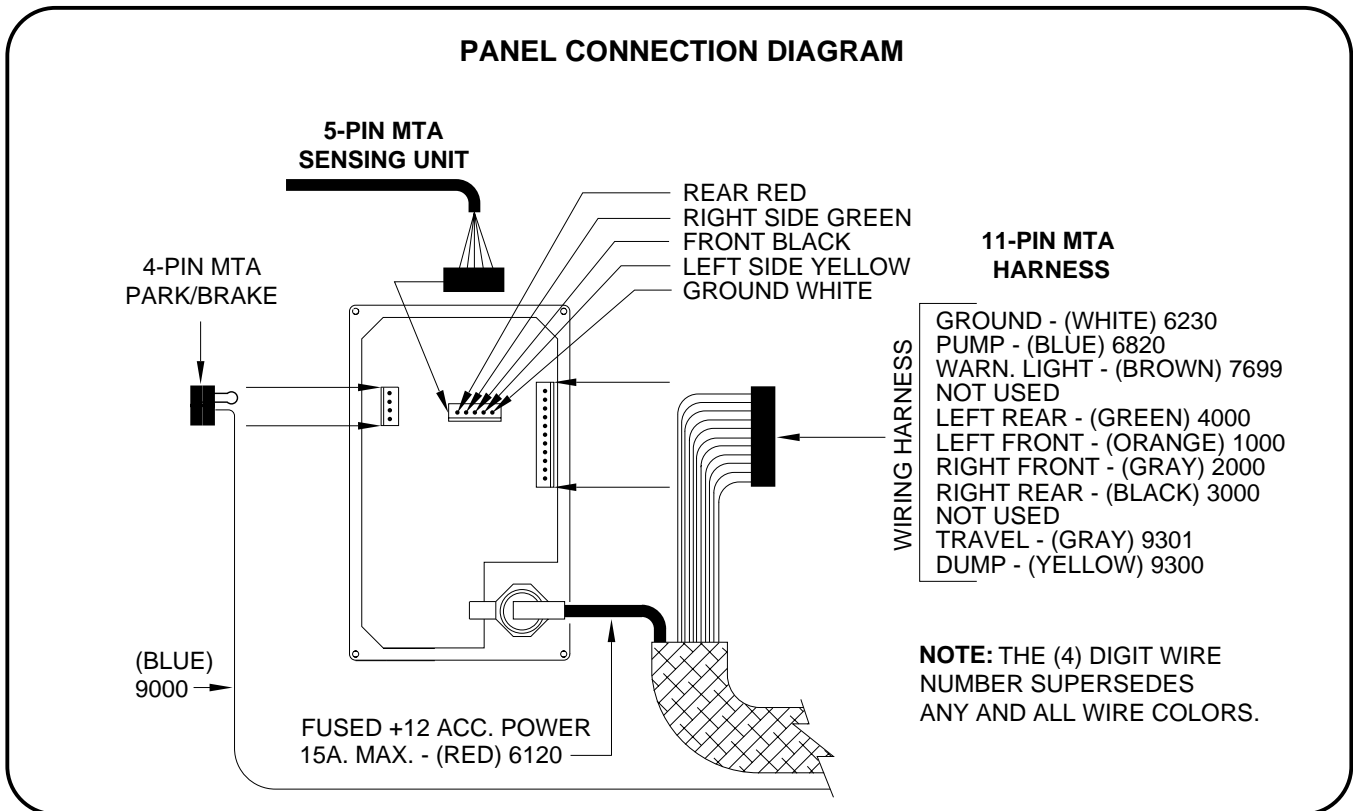
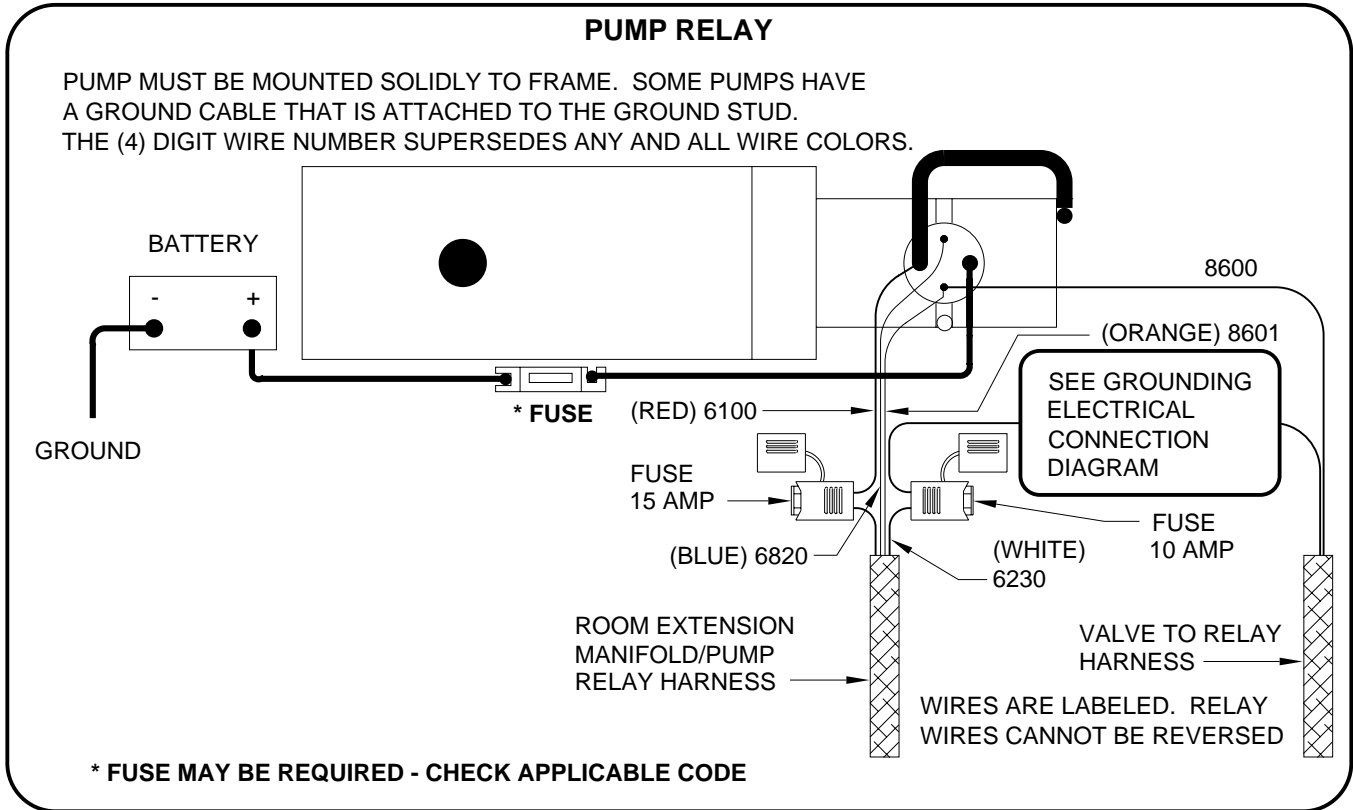

ELECTRICAL CONNECTION DIAGRAM

ROOM EXTENSION INTERFACE

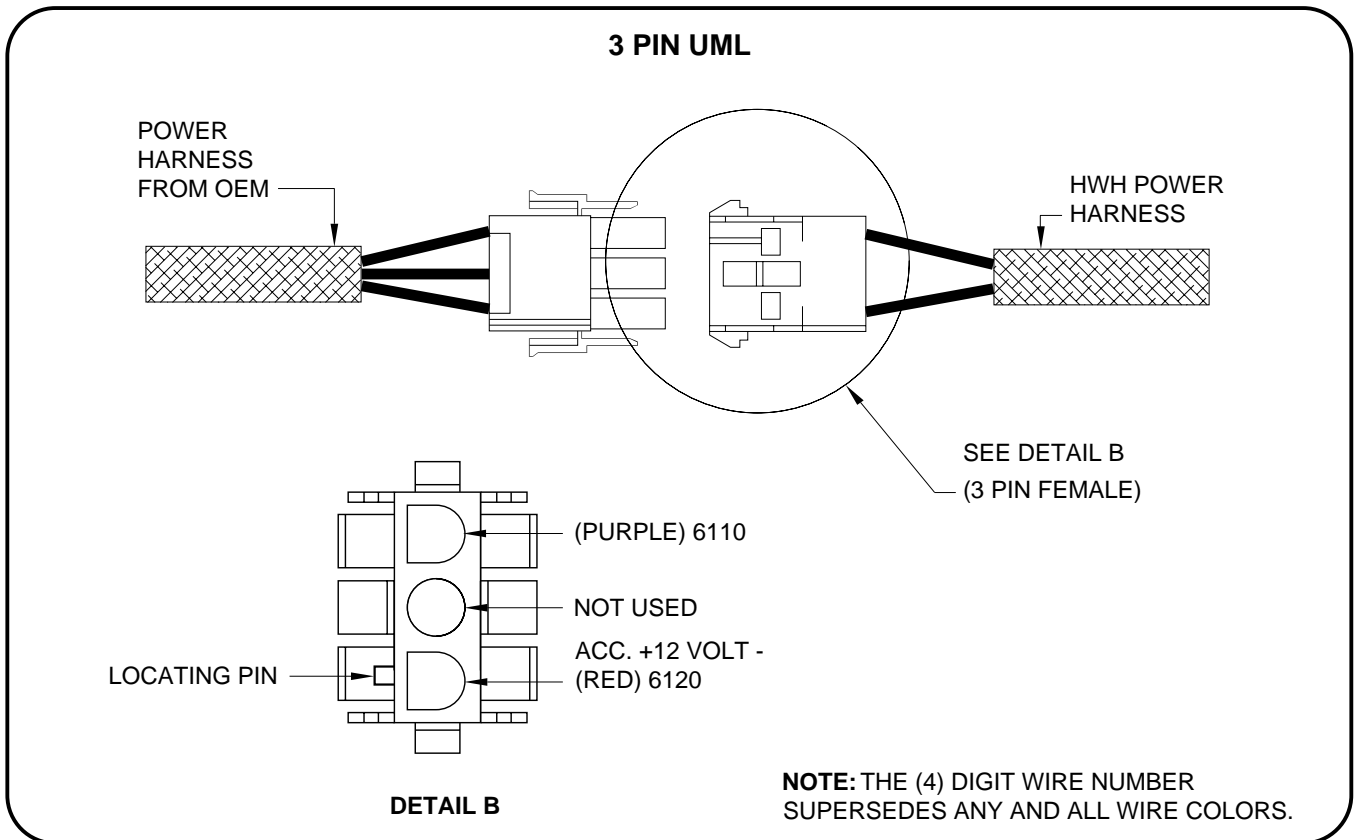
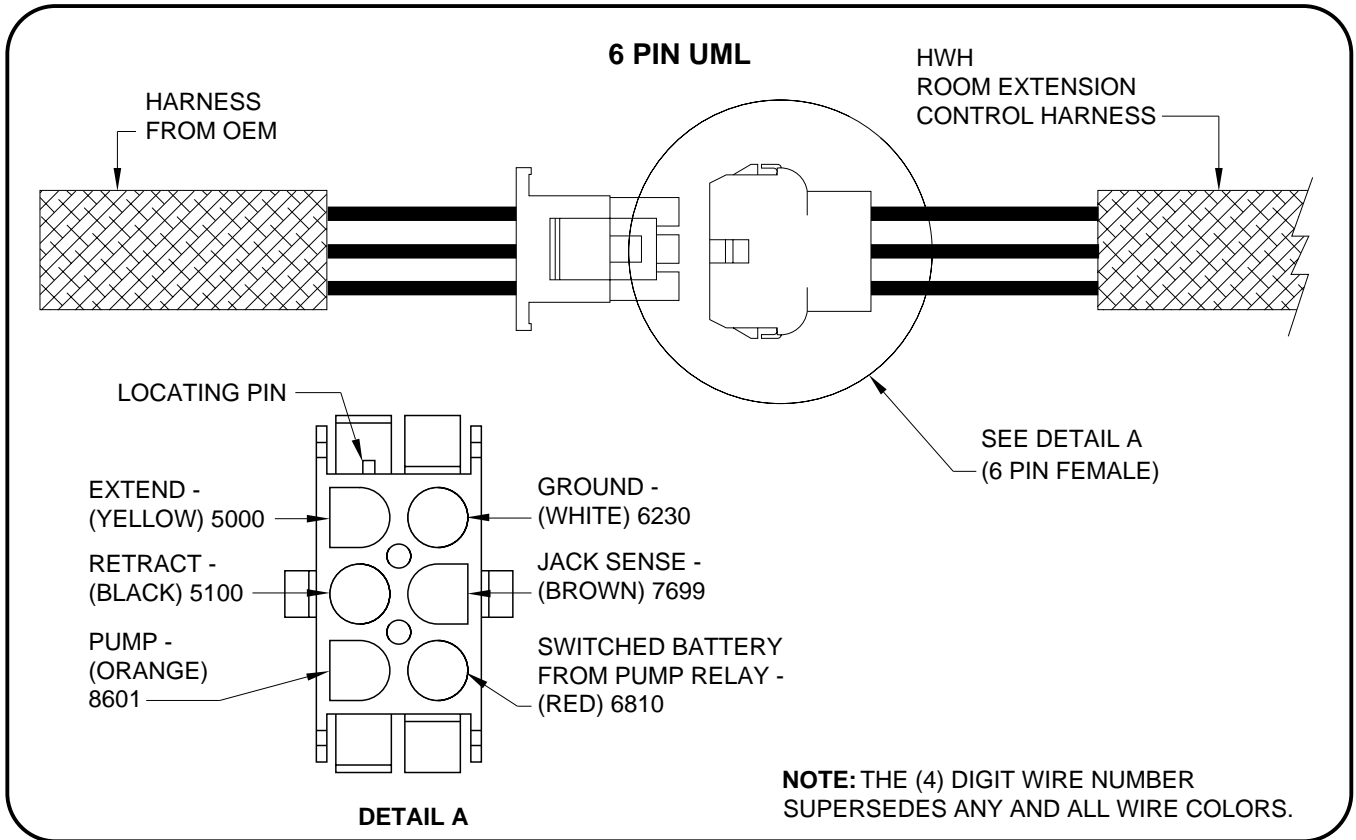

ELECTRICAL CONNECTION DIAGRAM BI-AXIS VALVE LEVELING SYSTEM WITH ROOM EXTENSION GROUNDING AND ROOM EXTENSION MANIFOLD CONNECTION

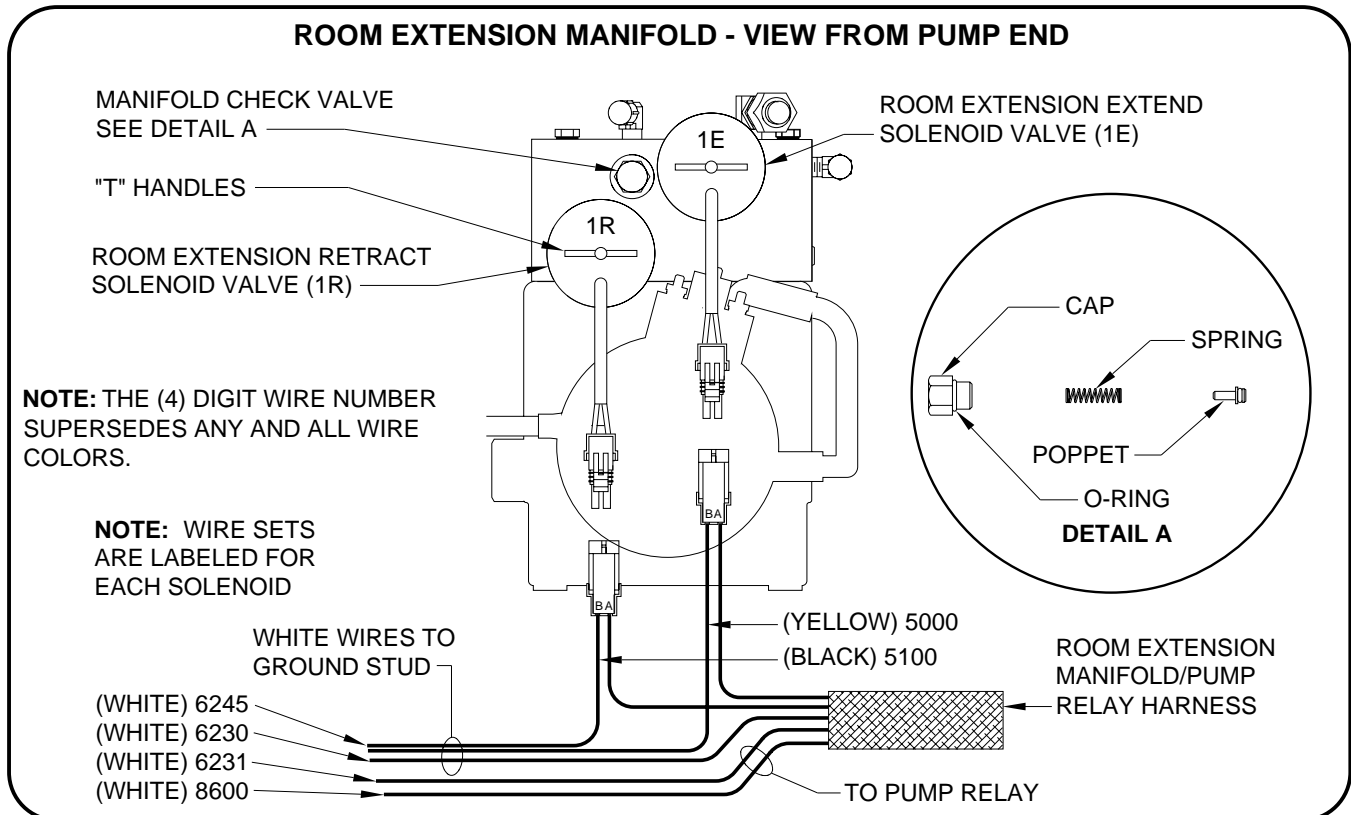
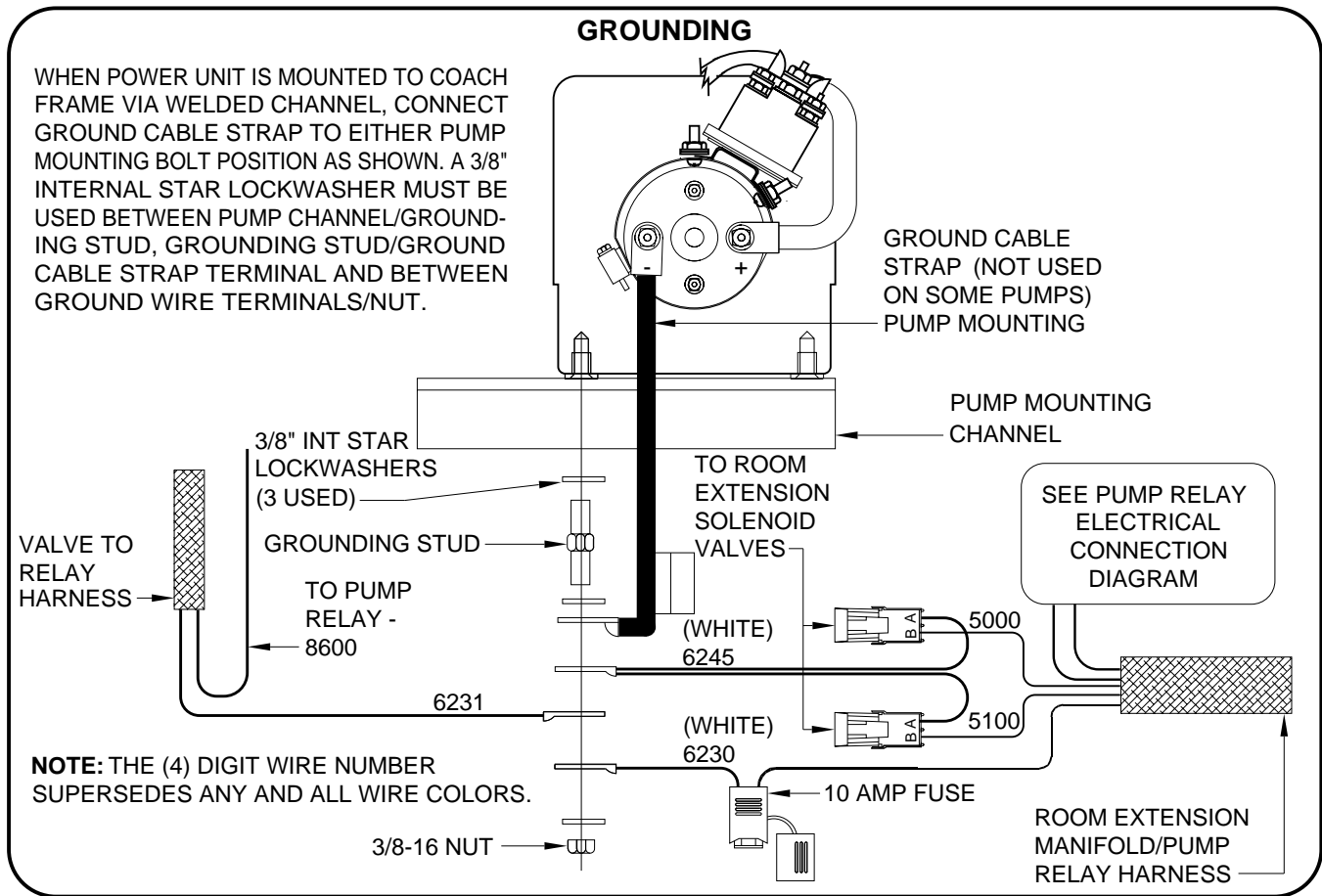

MASTER LIGHT/BUZZER CONNECTION DIAGRAM

JOY STICK CONTROLLED LEVELING SYSTEMS

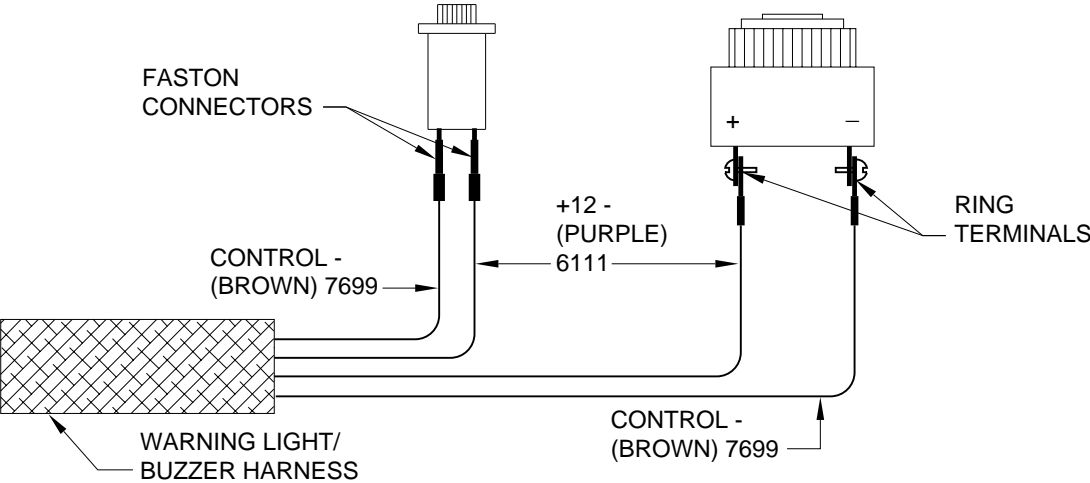

NOTE: THE (4) DIGIT WIRE NUMBER SUPERSEDES ANY AND ALL WIRE COLORS.

ELECTRICAL SCHEMATIC

200 SERIES, BI-AXIS LEVELING SYSTEM WITH HYDRAULIC ROOM EXTENSION SYSTEM

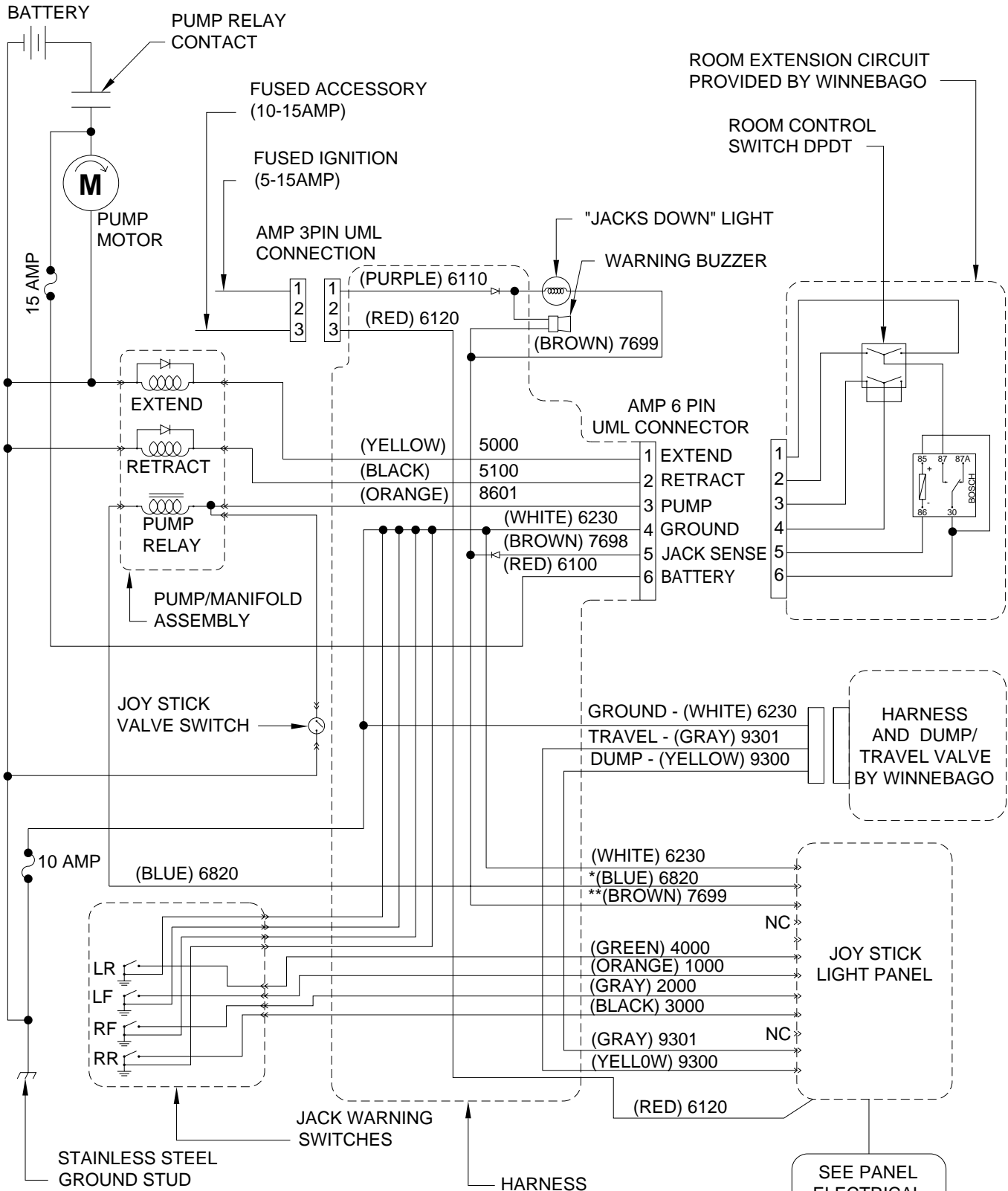

NOTE: THE (4) DIGIT WIRE NUMBER SUPERSEDES ANY AND ALL WIRE COLORS.

*** NOTE:** BLUE IS A POSITIVE SIGNAL, WHEN JOY STICK PANEL IS ON.

**** NOTE:** BROWN IS A NEGATIVE SIGNAL, WHEN A JACK IS DOWN.