

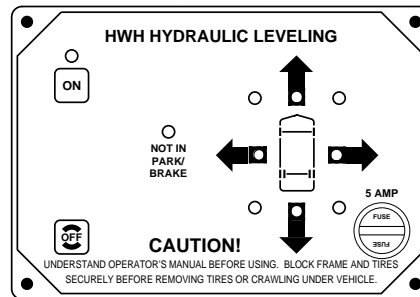

# OPERATOR'S MANUAL

## HWH® JOYSTICK-CONTROLLED 200 SERIES LEVELING SYSTEM

**FEATURING:**  
*Joystick BI-AXIS® Control*  
*Hydraulic Leveling*  
*Straight-Acting Jacks*

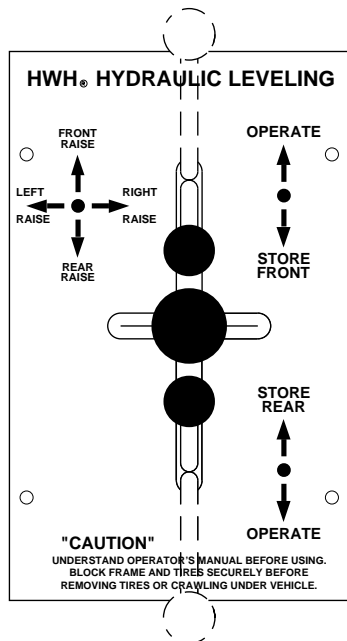

**HWH CORPORATION**  
(On I-80, Exit 267 South)  
2096 Moscow Road | Moscow, Iowa 52760  
Ph: 800/321-3494 (or) 563/724-3396 | Fax: 563/724-3408  
[www.hwh.com](http://www.hwh.com)

**AP0525 - U.S.**  
**AP10297 - Europe**

**ML0525/MP05.1501/LH-S**  
**26FEB04**

---

# OPERATOR'S MANUAL

---

## CAUTION !

READ THE ENTIRE OPERATOR'S MANUAL BEFORE OPERATING.

BLOCK FRAME AND TIRES SECURELY BEFORE CRAWLING UNDER VEHICLE. DO NOT USE LEVELING JACKS OR AIR SUSPENSION TO SUPPORT VEHICLE WHILE UNDER VEHICLE OR CHANGING TIRES. VEHICLE MAY DROP AND/OR MOVE FORWARD OR BACKWARD WITHOUT WARNING CAUSING INJURY OR DEATH.

KEEP ALL PEOPLE CLEAR OF VEHICLE WHILE LEVELING SYSTEM AND ROOM EXTENSION ARE BEING OPERATED.

THE JACKS MAY ABRUPTLY SWING UP WHEN THE FOOT CLEARS THE GROUND OR WHEN JACK REACHES FULL EXTENSION.

NEVER PLACE HANDS OR OTHER PARTS OF THE BODY NEAR HYDRAULIC LEAKS. OIL MAY PENETRATE SKIN CAUSING INJURY OR DEATH.

WEAR SAFETY GLASSES WHEN INSPECTING OR SERVICING THE SYSTEM TO PROTECT EYES FROM DIRT, METAL CHIPS, OIL LEAKS, ETC. FOLLOW ALL OTHER APPLICABLE SHOP SAFETY PRACTICES.

IF THIS VEHICLE IS EQUIPPED WITH KICK-DOWN STYLE JACKS, DO NOT OVER EXTEND THE REAR JACKS. IF THE WEIGHT OF THE VEHICLE IS REMOVED FROM ONE OR BOTH REAR WHEELS, THE VEHICLE MAY ROLL FORWARD OR BACKWARD OFF THE JACKS.

NOTE: KEEP THE CONTROL VALVE LEVERS IN THE STORE POSITION WHEN JACKS ARE NOT IN USE.

IMPORTANT: IF VEHICLE IS EQUIPPED WITH A ROOM EXTENSION, READ ROOM EXTENSION SECTION BEFORE OPERATING LEVELING SYSTEM.

## HOW TO OBTAIN WARRANTY SERVICE

### THIS IS NOT TO BE INTERPRETED AS A STATEMENT OF WARRANTY

HWH CORPORATION strives to maintain the highest level of customer satisfaction. Therefore, if you discover a defect or problem, please do the following:

**FIRST:** Notify the dealership where you purchased the vehicle or had the leveling system installed. Dealership management people are in the best position to resolve the problem quickly. If the dealer has difficulty solving the problem, he should immediately contact the Customer Service Department, at HWH CORPORATION.

**SECOND:** If your dealer cannot or will not solve the problem, notify the Customer Service Department:  
HWH CORPORATION 2096 Moscow Rd. Moscow IA. 52760  
(563) 724-3396 OR (800) 321-3494. Give your name and address, coach manufacturer and model year, date the coach was purchased, or the date of system installation,

description of the problem, and where you can be reached during business hours (8:00 a.m. till 5:00 p.m. c.s.t.). HWH CORPORATION personnel will contact you to determine whether or not your claim is valid. If it is, HWH CORPORATION will authorize repair or replacement of the defective part, either by appointment at the factory or by the authorization of an independent service facility, to be determined by HWH CORPORATION. All warranty repairs must be performed by an independent service facility authorized by HWH CORPORATION, or at the HWH CORPORATION factory, unless prior written approval has been obtained from proper HWH CORPORATION personnel.

# CONTROL IDENTIFICATION

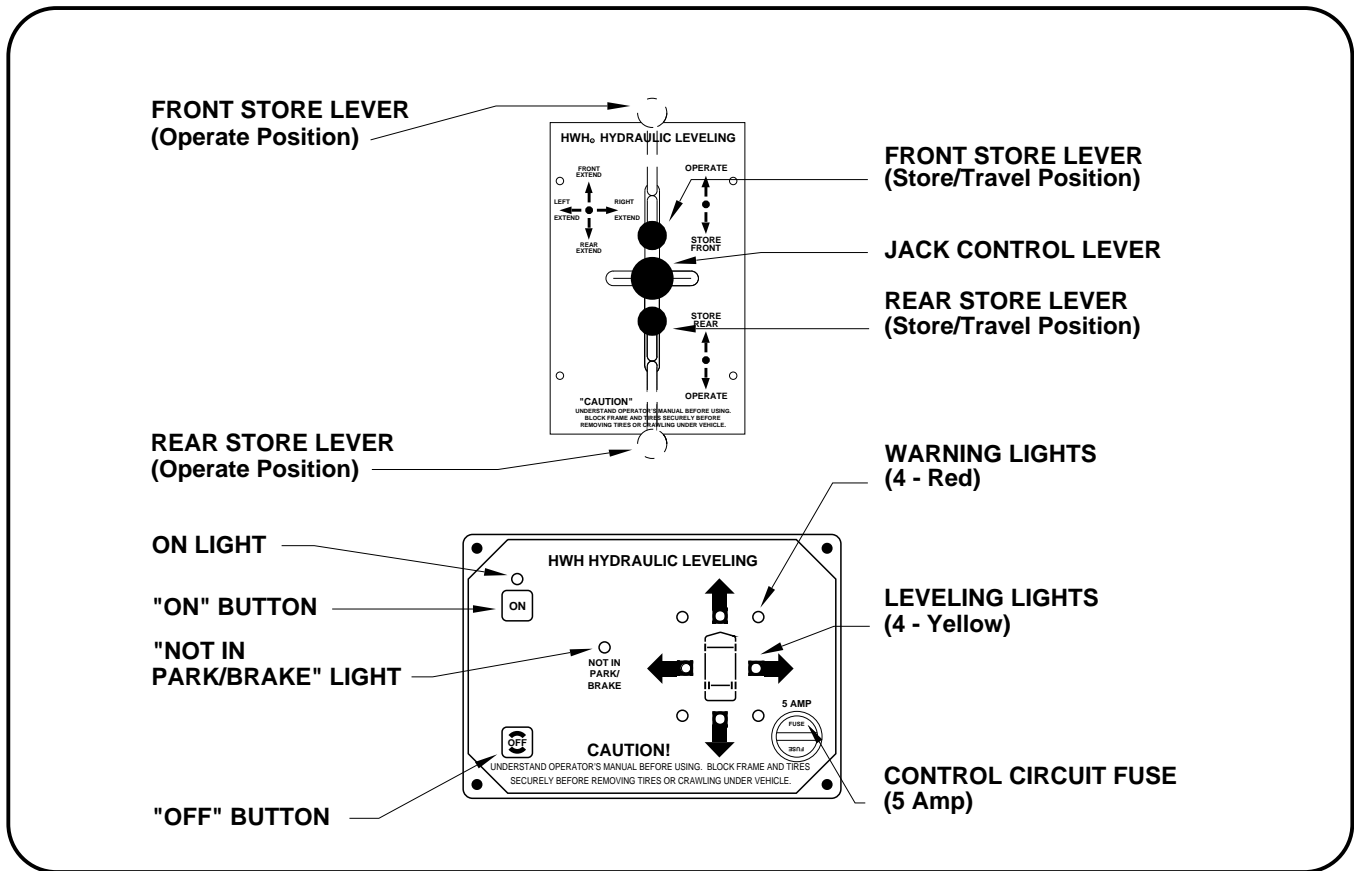

# CONTROL FUNCTIONS

## CONTROL BUTTONS

**"ON" BUTTON:** This is the "ON" button for the leveling system. It provides control power to operate the electrical relay on the pump, the LEVELING lights and the 4 red WARNING lights. It does not control power to the master "JACKS DOWN" warning light or buzzer.

**"OFF" BUTTON:** This button turns off control power to the leveling system, but not the master WARNING light or buzzer.

**STORE LEVERS:** These two levers are used to retract the jacks into the STORE/TRAVEL position. They must be in the operate position for leveling.

**JACK CONTROL LEVER:** Jacks are extended in pairs by pushing the jack control lever to one of the EXTEND positions. This movement of the lever activates the pump and directs hydraulic fluid to the jacks. When the lever is released it will return to the neutral (center) position, turning off the pump and stopping jacks in position.

## INDICATOR LIGHTS

**ON LIGHT:** This light indicates the system is on.

**"NOT IN PARK/BRAKE" LIGHT:** This indicator light is on when the "ON" button is pushed, but the hand/auto park brake is not set. The panel will not turn on.

**LEVELING LIGHTS:** If a yellow LEVELING light is on, that indicates a side or end of the vehicle is low. Extend the appropriate jack pairs to put out the yellow light. Only one yellow LEVELING light should be on at a time. The vehicle is level when all yellow lights are out.

**WARNING LIGHTS:** A red WARNING light will be on whenever the corresponding jack is extended 2 inches or more provided the ignition switch is in the "ACC" or "ON" position and the panel is on. Some vehicles are equipped with a dash mounted master "JACKS DOWN" light which will be on when one or more jacks are extended 2 inches or more, provided the ignition switch is "ON".

**WARNING BUZZER:** A buzzer will sound if a jack is extended 2 inches or more and the ignition switch is "ON".

# OPERATING PROCEDURES

## SITE SELECTION

Maintain adequate clearance in all directions for vehicle, room extensions, awnings, doors, steps ect. Vehicle may move in any direction due to jack extending or retracting,

settling of jacks or vehicle, equipment malfunction etc. If parking on soft ground or asphalt paving, wood blocks or pads should be placed under the jacks.

## ROOM EXTENSION PROCEDURES

**IMPORTANT:** If the vehicle is equipped with a room extension read this section carefully.

Refer to the vehicle owner's manual for proper operation of room extensions.

If the vehicle is equipped with kick-down jacks, the wheels **MUST** be blocked securely. Do **NOT** operate any room extension until the leveling and stabilizing procedure is complete. Do **NOT** retract the leveling system until all room extensions are retracted. **NEVER** operate the leveling system when any room extensions are extended.

**IMPORTANT:** Do not use a room extension support when the vehicle is supported by the leveling system.

## LEVELING PROCEDURE

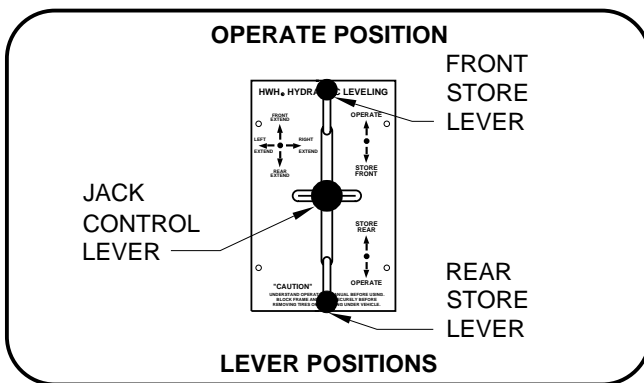

**NOTE:** The respective RED WARNING LIGHT will come on when a jack is extended 2 or more inches.

5. A lit yellow LEVEL light indicates that the end, side or corner of the vehicle is low. Only one yellow LEVEL light should be lit at a time. If a corner of the vehicle is low a side LEVEL light will be on by itself.

Move the JACK CONTROL LEVER to the EXTEND position to extend jack pairs corresponding to a lit yellow light. Extend jack pairs accordingly until all yellow lights are out. It may take several movements from side to front, or side to rear to raise a low corner. If the ground is too uneven, the jacks may not have enough stroke to level the vehicle. The vehicle may have to be moved.

1. Place gear selector in the parking position, apply park brake and block tires securely.

**NOTE:** If the hand/auto park brake is not set, the "NOT IN PARK/BRAKE" light will come on while the "ON" button is pushed. The panel will not turn on if the park brake is not set.

2. Turn the ignition switch to "ACCESSORY".

3. Push the "ON" button on the light plate. The POWER ON light will be lit.

4. Move the FRONT and REAR STORE LEVERS to the OPERATE POSITION. Nothing should happen at this time. Place pads under jacks if necessary at this time.

6. After the vehicle is level, the jacks not used for leveling may be extended until they touch the ground. This provides additional stability against wind and activity in the vehicle. Do this by pushing the jack control lever to the rear and/or front as needed to extend any remaining jacks. Do not use the right or the left extend positions. Jacks used to stabilize the vehicle should lift the vehicle 3/4" to 1" after touching the ground.

7. Push the "OFF" button on the light panel.

8. Turn the ignition switch off.

# OPERATING PROCEDURES

## RETRACT PROCEDURES

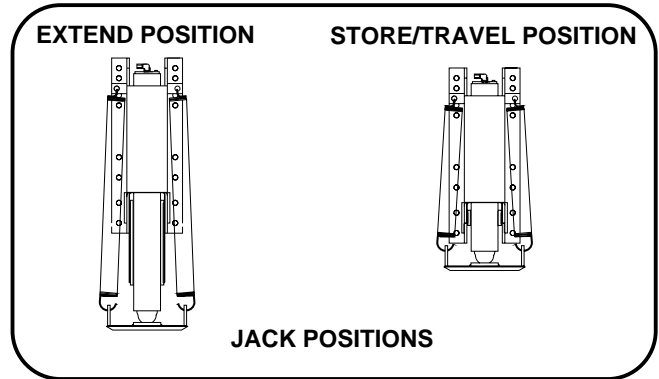
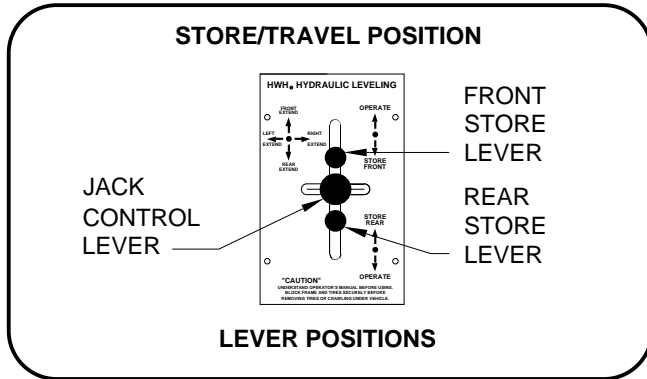

**CAUTION:** MAKE SURE THAT PEOPLE AND EQUIPMENT ARE CLEAR OF THE VEHICLE.

1. Move the STORE LEVERS to the STORE/TRAVEL POSITION. This will allow the jacks to retract.

**CAUTION:** THE STORE LEVERS SHOULD BE KEPT IN THE "STORE" POSITION WHILE TRAVELING TO KEEP THE JACKS IN THE STORE/TRAVEL POSITION.

2. Visually check that all jacks are in the STORE/TRAVEL position. With the ignition switch in the "ON" or "ACCESSORY" position, and the system turned on, the red WARNING lights, the master "JACKS DOWN" light and the buzzer will be off.

**CAUTION:** DO NOT MOVE THE VEHICLE WHILE THE LEVELING JACKS ARE STILL IN CONTACT WITH THE GROUND OR IN THE EXTEND POSITION. THIS VEHICLE IS EQUIPPED WITH STRAIGHT-ACTING JACKS. MOVING THE VEHICLE WITH THE LEVELING JACKS EXTENDED CAN CAUSE SEVERE DAMAGE TO THE JACKS AND OR THE VEHICLE AND CREATE A DRIVING HAZARD. DO NOT RELY SOLELY UPON WARNING LIGHTS. IT IS THE OPERATOR'S RESPONSIBILITY TO CHECK THAT ALL JACKS ARE FULLY RETRACTED INTO THE STORE/TRAVEL POSITION.

3. Push the "OFF" button on the light panel. Turn ignition off or proceed to travel.

**NOTE:** If the vehicle is parked or stored with the jacks extended for an extended period of time and the jacks fail to retract completely, extend the jacks back down to the ground then retract the jacks again.

# MAINTENANCE

## OIL LEVEL

It is important that the four leveling jacks and all HWH room extensions are fully retracted before checking the oil level. To check the oil supply, remove the breather cap from the top of the hydraulic reservoir. The oil level should be approximately one inch below the top of the reservoir when adequately filled.

**FLUID:** HWH Specialty Hydraulic Oil is recommended. In an emergency Dexron automatic transmission fluid can be used.  
**NOTE:** Dexron automatic transmission fluid contains red dye and can cause staining should a leak occur. **DO NOT USE** brake fluid or hydraulic jack fluid. Use of these can damage seals.

## ELECTRICAL SYSTEM

The batteries should be in good condition and fully charged. All electrical connections, especially ground connections, should be clean, tight, free from corrosion and protected

from corrosion. Weak batteries can cause erratic operation. Battery cable terminals, battery posts and connections should be kept clean and protected from corrosion.

## UNUSUAL CONDITIONS

If driving conditions are unusually muddy, the jacks may become caked or clogged with mud. This condition may hamper the proper operation of the leveling system. This problem may be prevented or remedied by cleaning off each leveling jack if they become excessively muddy.

Do not move the vehicle while the leveling jacks are still in contact with the ground. Place the system in the store mode and then visually check to see if the leveling jacks have returned to the STORE/TRAVEL position.

In wet or icy weather leveling jacks may become encrusted with ice. This may cause the leveling system to function improperly. To eliminate this problem, periodically check the leveling jacks and break loose any ice which may be causing improper operation.

**NOTE:** All major components of the system can be replaced with rebuilt parts or can be sent to HWH CORPORATION to be rebuilt, when the system is out of warranty.

## LEVEL SENSING UNIT ADJUSTMENT

Level the vehicle by placing a circular bubble level in the center of the freezer floor or location within the vehicle that is to be level. With the vehicle level, adjust the sensing unit until all yellow lights are off. This is done by drawing up the corresponding screw if the sensing unit is mounted below the surface as shown or backing out the corresponding screw if the sensing unit is mounted above the surface. Bump the sensing unit to see that it is settled tight against all three screw heads and still indicates that the unit is level.

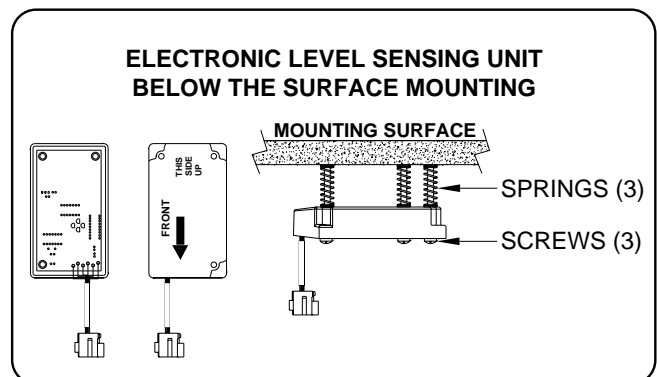
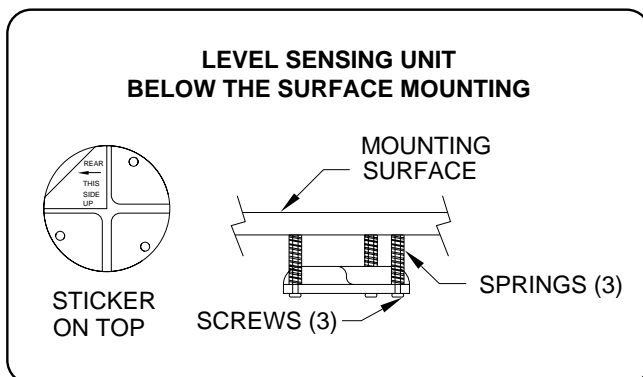

---

# TROUBLE SHOOTING

## 210/225 SERIES BI-AXIS VALVE

---

The following is a list of problems, and possible solutions, which might occur to the leveling system.

**NOTE:** Only qualified technicians should install or repair leveling systems on vehicles. A knowledge of hydraulics, welding, the vehicle's suspension and electrical systems as well as an understanding of the leveling system's hydraulic and electronics is required.

**1. JACK RETRACTS AFTER COACH IS LEVEL.**

- A. Hose or jack has external leak.
- B. Fluid is leaking back to reservoir through the control valve.
- C. Thermal contraction of fluid, jacks not lifting enough when stabilizing the vehicle.
- D. Bezel plate not installed properly - interferes with STORE levers.

**2. JACKS WILL NOT RETRACT COMPLETELY.**

- A. Jack clogged with mud or ice.
- B. Main rod bent or scored.
- C. Valve plunger is not completely depressed by valve handle.
- D. Spring weak or broken.
- E. Hydraulic line pinched.

**3. IGNITION SWITCH IS ON, BUT NO POWER TO PUMP AND/OR LIGHTS.**

- A. Park brake not set.
- B. 12 volts from power source not present.
- C. Faulty PC board.
- D. Faulty wire or electrical connection.

**4. PUMP WILL NOT ACTIVATE.**

- A. Grounding switch on valve not working.
- B. Pump relay not functioning.
- C. Pump not grounded.

**5. HYDRAULIC PUMP ACTIVATES WITHOUT USE OF CONTROL VALVE HANDLES.**

- A. Grounding switch at valve shorted.
- B. Pump relay stuck.
- C. Relay control wire shorted to ground.

**6. HYDRAULIC PUMP ACTIVATES, BUT THE JACKS WILL NOT EXTEND.**

- A. Store levers not in the operate position.
- B. Oil supply is low in reservoir.
- C. Pump is not developing pressure.
- D. Broken hydraulic line.

**7. LEVELING LIGHTS (YELLOW) ARE NOT FUNCTIONING PROPERLY.**

- A. Yellow lights will not go out when vehicle is level: adjust sensing unit.
- B. If two or more yellow lights are on replace PC board or check level sensing unit.

**8. WARNING LIGHTS (RED) ARE NOT FUNCTIONING PROPERLY.**

- A. Light will not come on: check for broken wire at warning switch on the jack.
- B. Lights will not go out: bad warning switch or wires are shorted to ground.
- C. Check PC board.

---

# HYDRAULIC LINE CONNECTION DIAGRAM 200/210/225 SERIES BI-AXIS VALVE

---

**NOTE:** Hose fittings at the pump will come directly out of the pump or if equipped with a room manifold, out of the top of the room manifold.

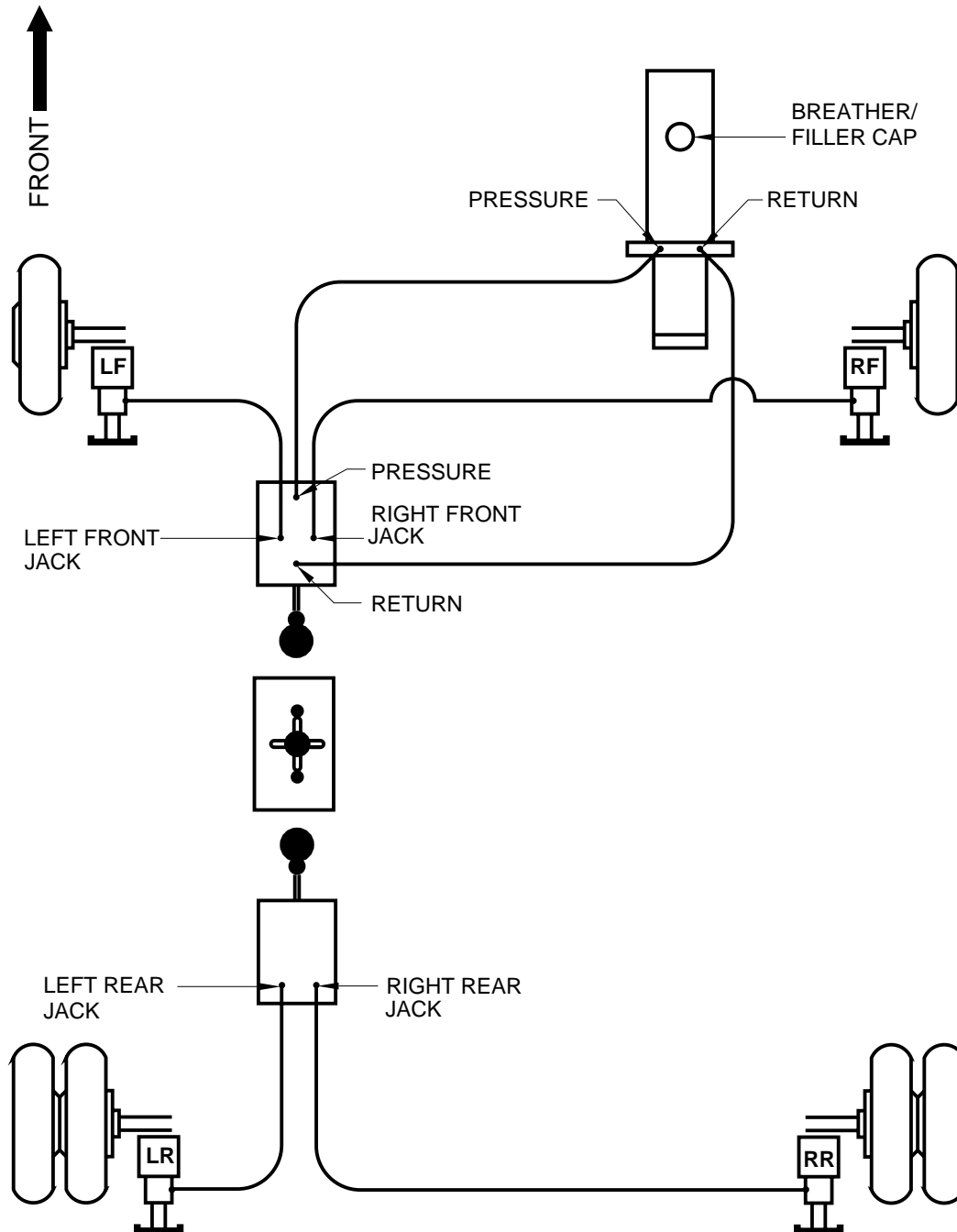

# ELECTRICAL CONNECTION DIAGRAM 200 SERIES LEVELING SYSTEM

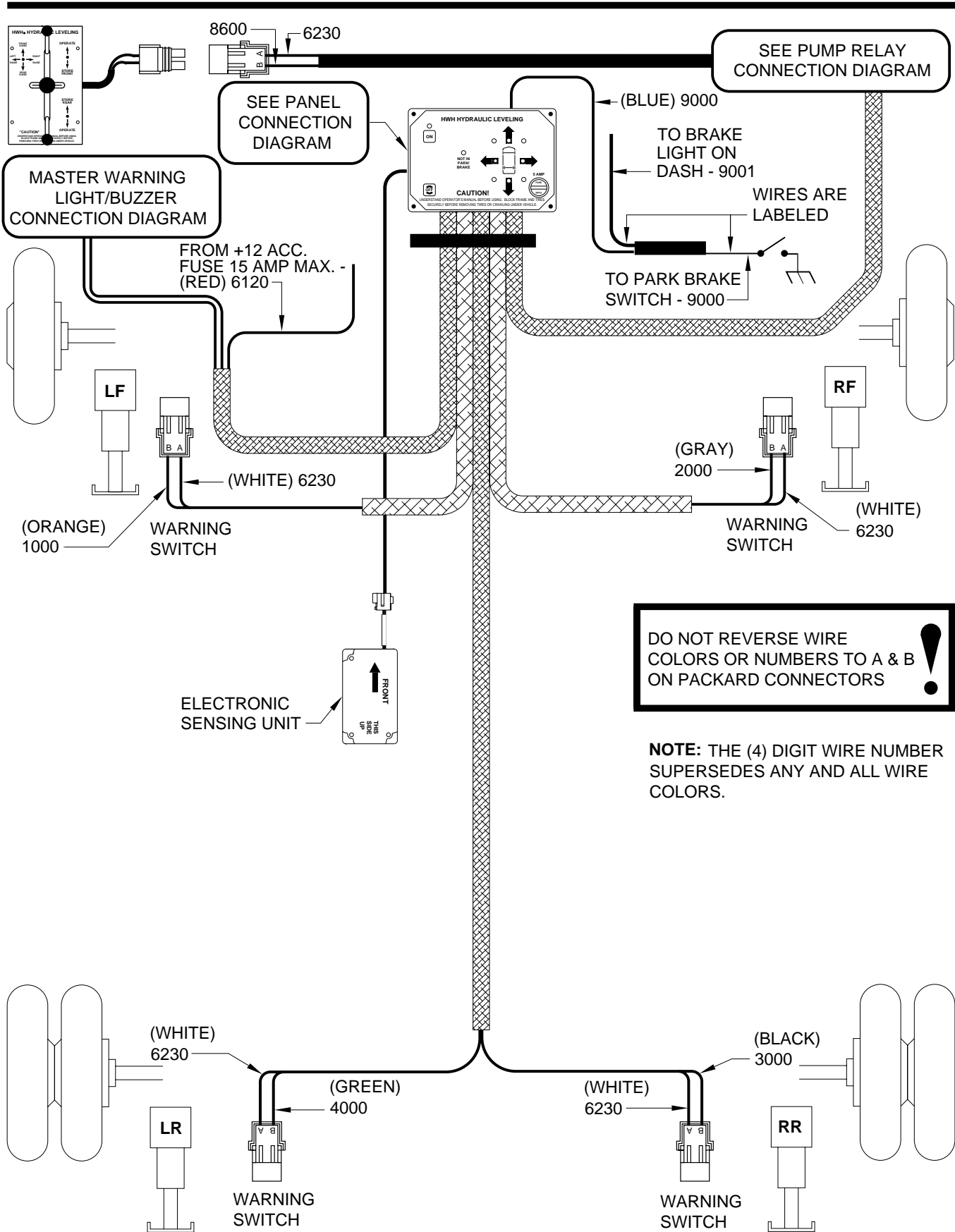

# ELECTRICAL CONNECTION DIAGRAM 200 SERIES LEVELING SYSTEM

## PUMP RELAY CONNECTION DIAGRAM

PUMP MUST BE MOUNTED SOLIDLY TO FRAME. SOME PUMPS HAVE A GROUND CABLE THAT IS TO BE ATTACHED TO THE GROUND STUD.

**NOTE:** THE (4) DIGIT WIRE NUMBER SUPERSEDES ANY AND ALL WIRE COLORS.

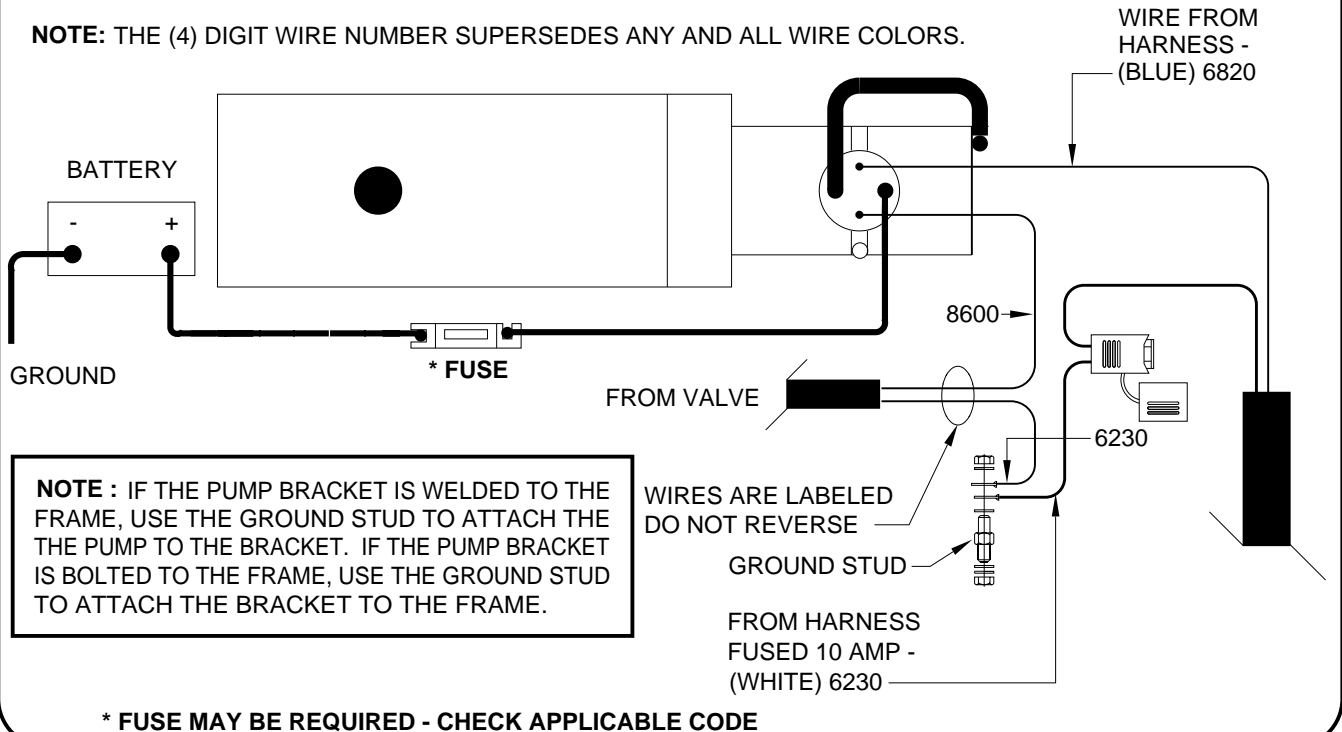

## PANEL CONNECTION DIAGRAM

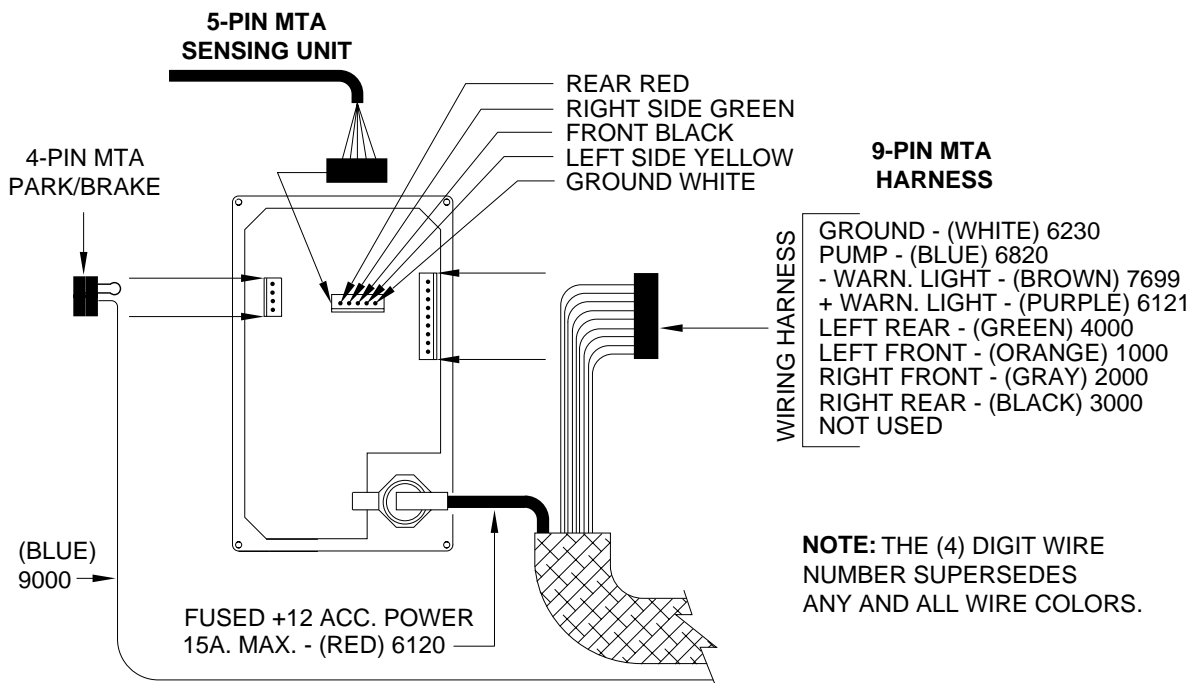



# MASTER LIGHT/BUZZER CONNECTION DIAGRAM MANUAL LEVELING SYSTEMS

A MASTER WARNING INDICATOR SHOULD ALWAYS BE USED. WHEN THE LEVELING SYSTEM HAS STRAIGHT-ACTING JACKS A WARNING BUZZER MUST BE USED.

WHEN ONLY A RED MASTER WARNING LIGHT IS USED THE 12+ POWER FOR THE LIGHT COMES THROUGH THE CONTROL PANEL. (SEE FIGURE 1 BELOW.) WHEN BOTH A RED LIGHT AND WARNING BUZZER ARE USED THE +12 POWER FOR BOTH INDICATORS IS SUPPLIED BY THE IGNITION SWITCH. THE POWER MUST COME FROM THE "ON" SIDE OF THE IGNITION SWITCH, NOT THE "ACC" SIDE. (SEE FIGURE 2 BELOW)

**NOTE:** BY SUPPLYING IGNITION POWER TO THE WARNING BUZZER AND LIGHT, AND "ACC" POWER TO THE CONTROL PANEL, THE SYSTEM MAY BE OPERATED IN ACCESSORY WITHOUT THE BUZZER SOUNDING. THE NEGATIVE SIGNAL FOR THE WARNING INDICATORS MUST ALWAYS COME FROM THE CONTROL PANEL.

**CAUTION:** THE PURPLE WIRE IN THE MASTER WARNING LIGHT HARNESS IS HOT WHENEVER THE IGNITION IS "ON" OR IN "ACC". THE PURPLE WIRE MUST BE REMOVED FROM THE HARNESS WHEN USING DIRECT IGNITION VOLTAGE FOR THE MASTER WARNING INDICATORS.

**NOTE:** THE (4) DIGIT WIRE NUMBER SUPERSEDES ANY AND ALL WIRE COLORS.

