

INFORMATION BULLETIN

ISSUE DATE: March 31, 2008

TO: Service Technicians

FROM: HWH Corporation

RE: Horizontal and Vertical Adjustments Kick-Down Jacks

HORIZONTAL AND VERTICAL ADJUSTMENTS KICK-DOWN JACKS

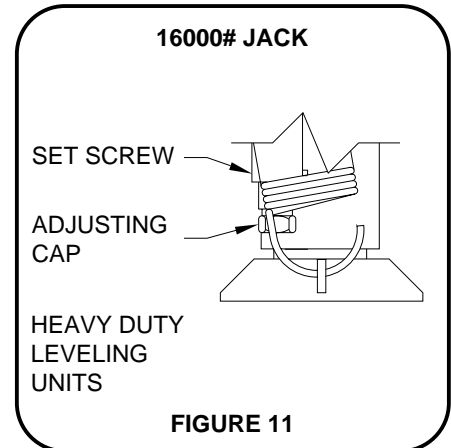
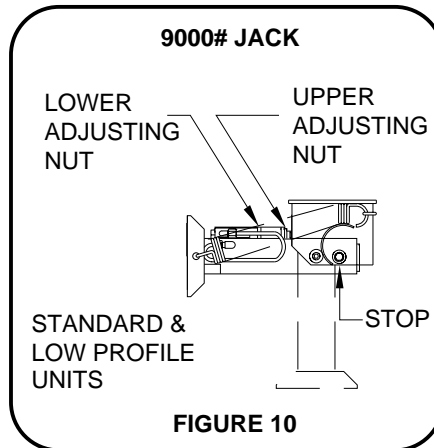
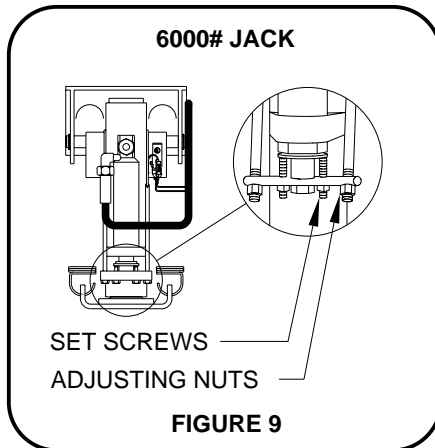

JACK ADJUSTMENTS - KICK DOWN JACKS ONLY

Each jack should be checked to be sure that it is vertical when it swings down. To do this retract all jacks, then extend each jack until it is close to but not touching the ground. Each jack must be adjusted so it can extend in the horizontal position without interfering with any suspension components, tanks, etc.

1. 6000# JACKS: Always make the vertical adjustment first. If the vertical adjustment is changed at any time, be sure to check the horizontal adjustment. Vertical adjustment is changed by adjusting the locknuts on the actuator cable. (FIGURE 9) If the jack stopped short of vertical, tighten the locknuts off. If the jack goes past vertical, back the locknuts off. Be sure to adjust each nut the same number of turns.

Horizontal stop is adjusted by turning the set screws located just inside the cable locknuts. The jack can be adjusted down to provide clearance for objects which may interfere with the operation of the jacks. The horizontal stop must be adjusted to provide clearance in case the jack extends in the horizontal position. The jack must be able to fully extend in the horizontal position without interfering with suspension components, tanks, etc.

2. 9000# JACKS: If the jack stopped short of being vertical it can be adjusted by loosening the lower actuator nut and tightening the upper actuator nut. (FIGURE 10) If the jack goes past vertical reverse the process.

The horizontal stop can be adjusted up or down in the slot to provide clearance for objects which may interfere with the operation of the jack (FIGURE 10). The stop must be adjusted so that the jack can be fully extended in the horizontal position without interfering with suspension components or tanks, etc.

3. 16000# JACKS: If the jack stopped short of being vertical, loosen the set screw and turn the adjusting cap clockwise. If the jack went beyond vertical, loosen the set screw and turn the adjusting cap counterclockwise. After each counterclockwise adjustment, the weight of the coach must be applied to the jack to make the adjustment effective. Do NOT adjust cap more than one turn without cycling the jack (FIGURE 11). The horizontal stop on the heavy-duty jack is adjusted by adding washers under the urethane stop.