

# Adapter Kit and 9,000# Jack Kit: Straight-Acting Jacks

**Application:** For mounting Straight-Acting Jacks on the REAR OF FORD F53 chassis, 1997 and older, 16" TIRES with a GRANNING TAG AXLE.

**Mfr. #: AP11672 Adapter Kit F53**

**Includes:** 1 - AP11615 Bracket Left Rear  
1 - AP11617 Bracket Right Rear  
2 - P11611 Bracket H-Plate  
1 - AP10116 Hardware Kit

**M.S.R.P.:** See Item Price Listing

**Mfr. #: AP11722 Jack Kit**

**Includes:** 1 - AP11517 2-Jack Assembly  
**M.S.R.P.:** See Item Price Listing

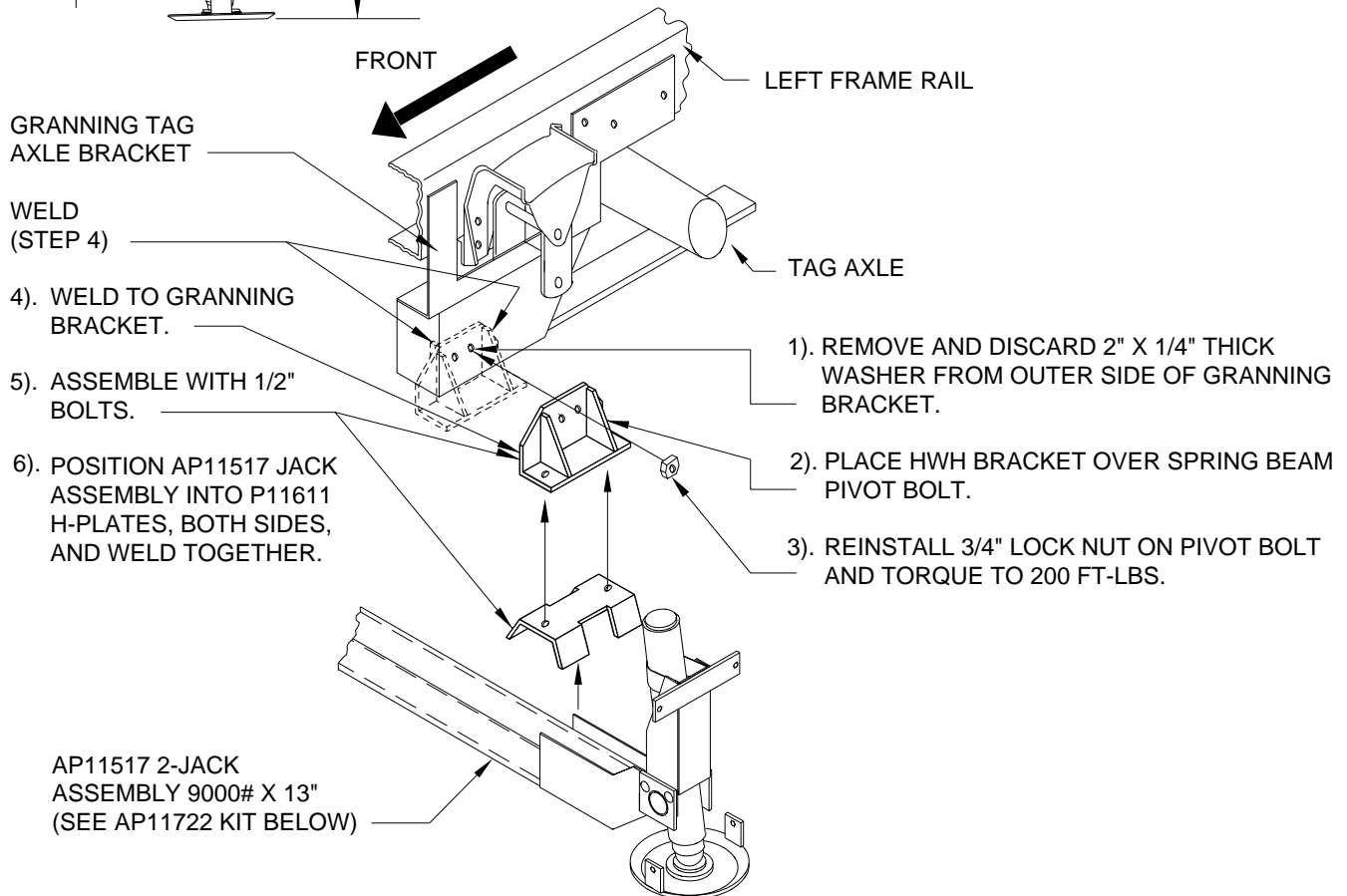
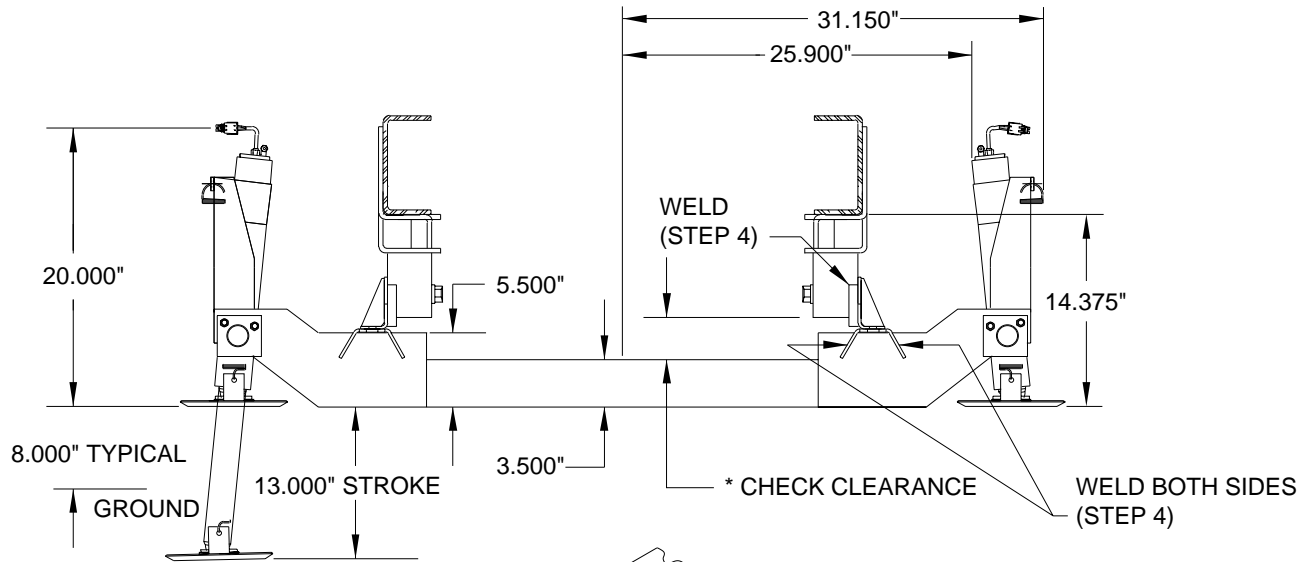

ABOVE DRAWING SHOWS JACKS MOUNTED OUTBOARD OF THE REAR SPRING HANGERS ON A FORD F53.

\* CLEARANCE BETWEEN TAG AXLE SWING ARM AND CROSS TIE SHOULD BE CHECKED WITH TAG AXLE AT FULL EXTENSION.

**CAUTION:** Follow CAUTIONS in Operator's and Installation Manuals concerning working under vehicles.

**MI25.4257**  
**16FEB01**