

INSTRUCTION SHEET

SENSING UNIT MAINTENANCE/SERVICE

REMOTE MOUNTED "POTTED" ELECTRONIC SENSING UNIT

SENSING UNIT ACCURACY TOLERANCE

The sensing unit has an accuracy tolerance of ± 5.4 inches front to rear and ± 1 inch side to side on a 36 foot vehicle. Typical leveling results will be better.

SENSING UNIT ADJUSTMENT

Level the vehicle by placing a bubble level in the center of the freezer floor or upon whichever surface within the vehicle that is to be level. Using the Leveling System and the bubble level, ignoring the yellow LEVEL lights on the Touch Panel, level the vehicle until the bubble is centered.

With the vehicle level according to the bubble level, if there are no yellow lights lit on the Touch Panel, the sensing unit is properly adjusted. If there are yellow LEVEL lights lit on the Touch Panel, manual adjustments to the Sensing Unit are needed. Tighten or loosen the adjustment screws according to these instructions to adjust the sensing unit.

IMPORTANT: BUMP THE SENSING UNIT TO SEE THAT IT IS SETTLED TIGHT AGAINST ALL THREE SCREW HEADS AND STILL INDICATES THAT THE UNIT IS LEVEL. ONCE THE SENSING UNIT IS MOUNTED WITH THE MOUNTING SPRINGS COMPRESSED HALFWAY, SCREW NUMBER 2 SHOULD NOT BE TURNED.

LED A - FRONT OF VEHICLE
 LED B - LEFT SIDE OF VEHICLE
 LED C - REAR OF VEHICLE
 LED D - RIGHT SIDE OF VEHICLE

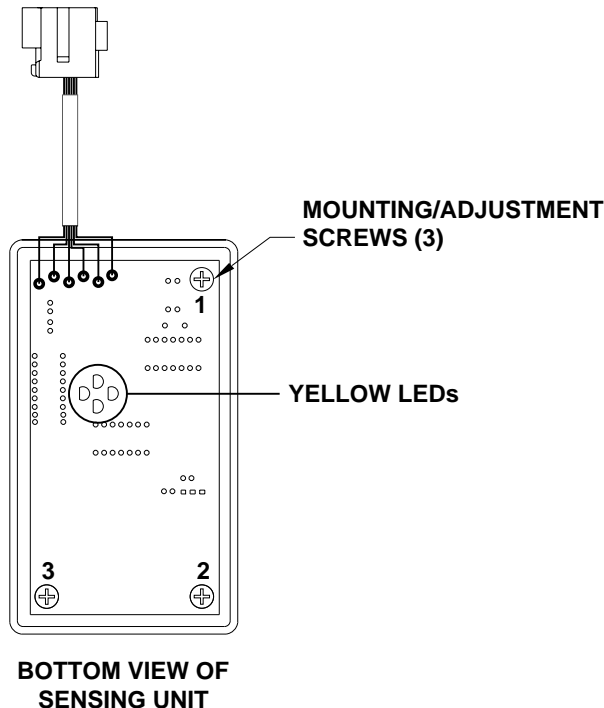

NOTE: If opposing LED's are lit, there is a problem with the Sensing Unit.

If LED (A) is lit: Tighten adjustment screw number 1 until the LED is off.

If LED (C) is lit: Loosen adjustment screw number 1 until the LED is off.

If LED (B) is lit: Loosen adjustment screw number 3 until the LED is off.

If LED (D) is lit: Tighten adjustment screw number 3 until the LED is off.

IMPORTANT: WHEN ALL 4 LED'S ARE OFF, MOVE THE VEHICLE TO AN UNLEVEL POSITION SO ONE OR TWO YELLOW LIGHTS ARE ON. LEVEL THE VEHICLE ACCORDING TO THE YELLOW LEVEL LIGHTS. RECHECK THE LEVEL. IF MORE ADJUSTMENT IS NEEDED, DO NOT TRY TO ADJUST THE SENSING UNIT UNTIL THE YELLOW LEVEL LIGHTS GO OUT, INSTEAD JUST "TWEAK" THE SENSING UNIT, IGNORING THE LED'S ON THE SENSING UNIT.

Example: After the initial adjustment and releveling the vehicle, the front is still low. This means the front yellow level light is turning off too soon. LED A is for the front of the vehicle. Move the adjustment for that light very, very, slightly in the OPPOSITE direction that is given in the above instructions for LED's A, B, C and D. This will allow the front yellow light to stay on slightly longer to bring the front up more. Again, unlevel the vehicle then relevel the vehicle using the yellow level lights on the touch panel. Recheck with a level. Repeat the "tweaking" process until the system levels the vehicle properly.

