

HWH CORPORATION
SWAGING SPEC FOR HWH - 04 HOSE

	<u>NUMBER ON PART</u>
HOSE END: _____	90304 - 045400
SWAG PUSHER: _____	4599 - FP012
SWAG DIE: _____	4540 - 3W400

**SWAG MUST BE CHECKED WITH A
CALIPERS OR MICROMETERS**

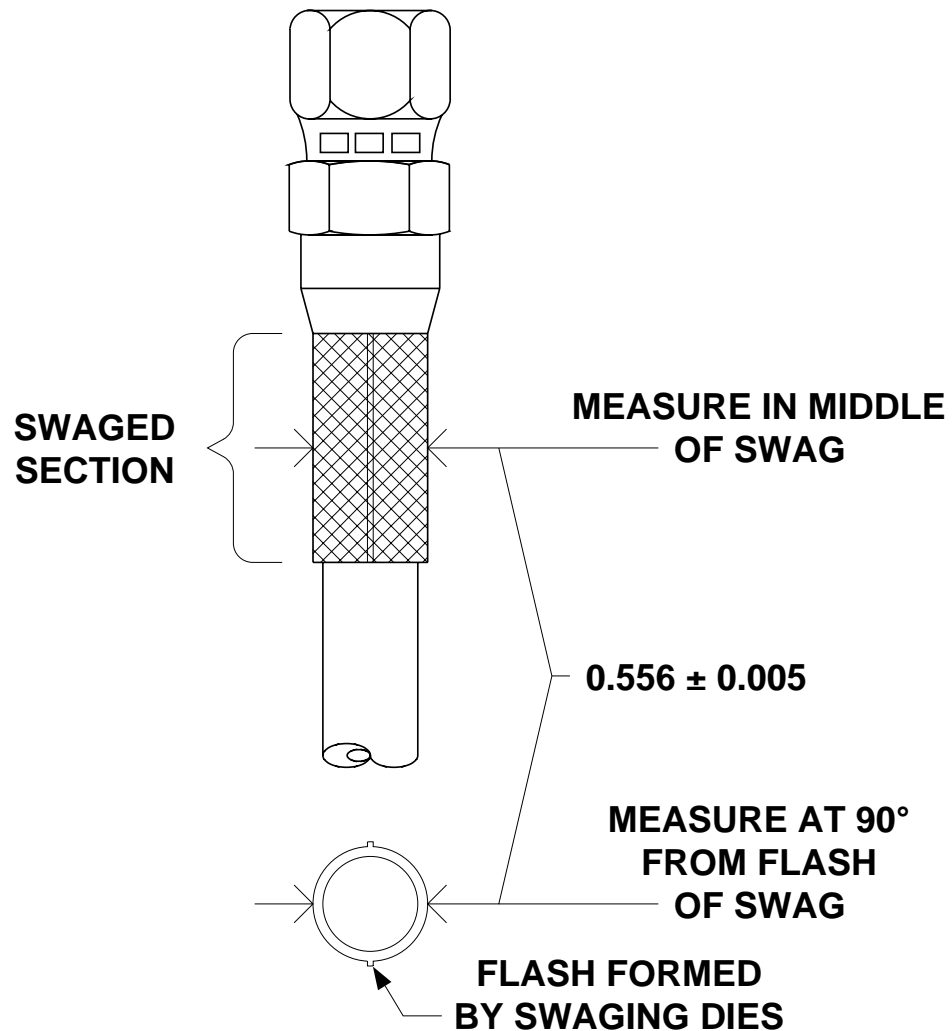

**LUBRICATE AREA TO BE SWAGED WITH A NICKEL BASE LUBRICANT
SUCH AS NEVER SEIZE OR A HEAVY DUTY 90 WEIGHT GEAR LUBE**